

TURKISH COMPETITION AUTHORITY

GUIDELINES ON UNDERTAKINGS CONCERNED, TURNOVER AND ANCILLARY RESTRAINTS IN MERGERS AND ACQUISITIONS

I. INTRODUCTION

- (1) Article 7 of the Act No 4054 on the Protection of Competition prohibits mergers and acquisitions with a view to creating a dominant position or strengthening an existing dominant position which would result in significant lessening of competition in a market for goods or services within the whole or a part of the country and it is stated that the Competition Board shall declare, via communiqués to be issued by it, the types of mergers and acquisitions which have to be notified to the Competition Board and for which permission has to be obtained, in order them to become legally valid. Within this framework, the Communiqué No 2010/4 concerning the Mergers and Acquisitions calling for the Authorization of the Competition Board, which was published on the Official Gazette dated 10.7.2010 and No 27722, was issued and replaced the Communiqué No 1997/1 as of 1.1.2011.
- (2) With the Communiqué No 2010/4, the system of notification thresholds based on turnover replaces the market share threshold system in order to increase legal certainty for undertakings. It is important to clarify, the concepts of undertaking concerned and transaction party and how the turnover is allocated in certain situations for finding whether the said thresholds are exceeded. Similarly, it is useful to explain the main issues related to ancillary restrains.
- (3) The aim of this guideline is to increase certainty and predictability for the application of the Communiqué No 2010/4 by making explanations about the concepts of undertaking concerned and transaction party mentioned in the Communiqué No 2010/4 as well as ancillary restrains and calculation of turnover thresholds. In addition, the Competition Board shall decide depending on the characteristics of each case.

II. CONCEPTS OF UNDERTAKING CONCERNED AND TRANSACTION PARTY

II.1. In General

- (4) The concepts of transaction party and undertaking concerned are important for the calculation of turnover, for determining whether the transaction is subject to authorization and for providing the information requested in the Notification form completely and accurately.
- (5) Article 4 of the Communiqué No 2010/4 titled "Definitions" defines undertakings concerned as merging persons or economic units in mergers; acquiring or acquired persons or economic units in acquisitions and defines transaction party as the undertaking party to the merger or acquisition. Accordingly, the undertaking concerned means the person or economic unit that is directly a party to a merger or an acquisition; a transaction party means the economic entity in which each undertaking concerned is included.
- (6) In mergers and acquisitions, after the undertakings concerned are determined, the turnovers of transaction parties, which will form the basis of the evaluation of thresholds, are calculated taking into consideration other persons and economic units that might be in relation with the undertakings concerned within the framework of paragraph 1 of Article 8 of the Communiqué No 2010/4. The procedure for determining the undertakings concerned in mergers and acquisitions under possible scenarios is given below:

II.2. Undertaking concerned in Mergers

- (7) Each of the merging persons or economic units is considered as an undertaking concerned individually in mergers.

II.3. Undertaking concerned in Acquisitions

- (8) In acquisitions, there may be more than one firm in both the acquiring party and the acquired party. As a general principle, each of those firms is considered as an undertaking concerned under the scope of the Communiqué No 2010/4. Moreover, as stated below, the definition of an undertaking concerned might be different based on a specific case depending on the structure of control in acquisitions.

II.3.1. Acquisition of full control

- (9) In transactions where an undertaking acquires the full control of another undertaking, undertakings concerned are the acquiring undertaking and the undertaking to be acquired. In case of acquisitions realized by a group through one of its companies, the undertakings concerned are the acquiring firm and the undertaking to be acquired, except for the case where the acquiring firm is established as an instrument for acquisition.

II.3.2. Partial Acquisition

- (10) In case the acquisition is related to acquiring one part of the undertaking to be acquired instead of the whole, the undertakings concerned will be the acquiring undertaking and the part to be acquired in the transferring firm. For instance, in a transaction where company A has more than one production facility and B acquires only one of them, the undertakings concerned are company B and the production facility to be acquired.

II.3.3. Transition from joint control to full control

- (11) In cases where one of the shareholders of a company that is managed through joint control establishes full control over the company by purchasing the shares of other shareholders, the undertakings concerned are the acquiring shareholder and the joint venture company. The shareholders who leave the company by transferring their shares are not considered as undertakings concerned. For instance, in a transaction where company D is jointly controlled by A, B and C, and company A acquires the shares belonging to B and C and therefore gains full control over D, the undertakings concerned are A and D.

II.3.4. Acquisition of joint control

- (12) In case a new joint venture is established, each of the shareholders who will have a voice in the joint control is regarded as an undertaking concerned. The newly established joint venture is not regarded as an undertaking concerned, as it does not have turnover. Where an undertaking transfers its subsidiary or its business as a contribution to a new joint venture, joint venture is not regarded as

an undertaking concerned. For instance, if companies A, B and C come together and establish the joint venture D, the undertakings concerned are A, B and C. The same condition applies where one of those companies transfers to company D an asset that can be attributed turnover.

(13) However, in case one or more undertakings acquire another company so as to establish joint control, each of the undertakings to have joint control after the transaction and the acquired company are regarded as undertakings concerned. The difference between this transaction and the example in the previous paragraph is that the joint venture is established on a company operating in the market independently of its shareholders. Here, a company that is active on the date of the transaction is being acquired by third parties in a way to establish joint control over it. Therefore, the acquired company is regarded as an undertaking concerned beside the shareholder undertaking.

(14) Acquisition of a company to share its assets in a short time is regarded as the acquisition of full control individually over the related parts of the acquired company by each of the acquirers not as the acquisition of joint control over the company as a whole. In this case, the undertakings concerned are the acquiring companies and different parts that are acquired in each transaction.

II.3.5 Change of the shareholders controlling the joint venture

(15) Where, in the joint venture, one or more shareholders are subsequently included in the joint control as a new shareholder or purchasing a part of the existing shares; due to the structural change in control, all previous and new shareholders who will have joint control and the joint venture itself are regarded as undertakings concerned. For instance, if company D is included in company C, which is jointly controlled by A and B, via purchasing all of the shares of company B, undertakings concerned will be A, C and D.

II.3.6. Acquisition of control by the joint venture

(16) Where a joint venture acquires the control of another company, the joint venture per se and each of the parent companies may be considered as an undertaking concerned. In those cases, the Competition Board determines the undertaking concerned depending on the following principles taking into account the

economic reality of the transaction.

(17) In case the acquisition is realized by a full-function joint venture, the undertakings concerned are the joint venture and the company acquired.

(18) In case the joint venture is used as an instrument in an acquisition by the parent companies, for instance if the joint venture is established only for the acquisition, is not a full-function joint venture and does not start operating yet, the parent companies are considered as the undertakings concerned, not the joint venture. Similarly, if there are facts showing that the parent companies are the real players behind the transaction, for instance if the parent companies significantly contribute to initiation, organization and financing of the transaction, the parent companies are regarded as the undertakings concerned.

II.3.7. Break-up of joint control

(19) When parent companies break up the joint venture and split the assets, there is more than one transfer of control. If each of the parent companies gains full control over the asset it has had after the transaction, the undertakings concerned for each transaction is the acquiring parent company and the asset acquired.

(20) A similar scenario applies to the situations where two or more companies exchange economic units. In this case, each transfer of control is considered as an acquisition of full control independently. The undertakings concerned will be the acquiring companies and the economic units acquired.

II.3.8. Acquisition of control by real persons

(21) Real persons are deemed as undertakings individually or when they carry out economic activities via their rights of control on an economic unit. In acquisitions realized by real persons who are deemed as undertakings, the undertakings concerned will be the acquiring real person and the economic unit acquired.

III. TURNOVER

III.1. In General

(22) According to Article 7 of the Communiqué No 2010/4, in a merger or acquisition,

authorization of the Competition Board is required for the relevant transaction to carry legal validity in case, total turnovers of the transaction parties in Turkey exceed one hundred million TL, and turnovers of at least two of the transaction parties in Turkey each exceed thirty million TL, or global turnover of one of the transaction parties exceeds five hundred million TL, and at least one of the remaining transaction parties has a turnover in Turkey exceeding five million TL. However, except in cases of joint ventures, authorization of the Competition Board is not required for transactions without any affected market, even if the thresholds listed in Article 7 are exceeded. Joint venture here means the existence of an economic unit subject to joint control after the transaction such as the formation of a new joint venture or the change in the control structure of an existing joint venture. Therefore, transactions not creating joint control are not deemed as joint ventures in the application of the said article.

- (23) The Competition Board tries to have the most accurate and reliable turnover figures in order to assess precisely the possible effects of the transaction in markets in control of merger and acquisition transactions. Within this framework, according to paragraph 6 of Article 8 of the Communiqué No 2010/4, in accordance with the uniform accounting plan, the net sales generated as of the end of the financial year preceding the date of the notification, or, if this can not be calculated, of those generated as of the end of the financial year closest to the date of notification are taken into account.
- (24) For converting the annual turnover of an undertaking in foreign currency to TL, average buying rate of exchange of the Central Bank of Turkey for the financial year the turnover is generated is taken into consideration as the rate of exchange.
- (25) When determining whether the turnover thresholds stated in Article 7 of the Communiqué No 2010/4 are exceeded, the turnovers of the undertaking concerned as well as of all persons and economic units that are connected to it according to the criteria stated in paragraph 1 of Article 8 of the Communiqué No 2010/4 are taken into account. The aim is to assess the total economic power of transaction parties through determining the total volume of economic sources affected by the transaction by complying with the legal certainty principle.
- (26) According to paragraph 2 of Article 8 of the Communiqué No 2010/4, for the

calculation of turnover in an acquisition, the turnover of the part transferred is taken into account with respect to the transferring party. For instance, if undertaking A is wishing to acquire undertaking C, which is fully controlled by undertaking B, the turnovers of A and C are included in the calculation and the turnover of B is ignored.

III.2. Affected Markets

- (27) Affected market indicates horizontal and vertical relations between relevant product markets. Within this framework, the fact that there is a relevant product market where the activities of the parties overlap horizontally or vertically fulfills the condition of the existence of an affected market provided that at least one party operates in Turkey. Moreover, if none of the parties operates in Turkey with respect to the relevant product markets where the activities of the parties overlap horizontally and vertically, it can be said that there is not an affected market for the application of the said paragraph.
- (28) Horizontal relationship indicates the overlap in the same level where at least two of the parties are commercially active in the same product market while vertical relationship indicates the cases where at least one of the parties is commercially active in the downstream or upstream market of any product market in which another party operates. For instance, when an undertaking operating in the cement sector even abroad acquires a cement factory operating in Turkey, an affected market will be in question due to the horizontal relationship in the cement market. In this case, the transaction will be subject to authorization if the turnover thresholds are exceeded. Similarly, if a cement company acquires a ready-mixed cement facility in Turkey, an affected market will be in question due to the vertical relationship in the markets, regardless of whether the company actually supplies goods to that facility. However, with respect to acquisitions without horizontal or vertical relationships between products (except joint ventures), for instance where an undertaking operating only in cement market acquires a company producing biscuits in Turkey, there will be no affected markets, therefore the transaction will not be subject to authorization regardless of turnovers.
- (29) Assessment of an affected market will be made in terms of markets that are likely to be affected by the transaction. Accordingly, all activities of undertakings will

be assessed in mergers within this framework. In acquisitions, assessment is made considering only the area of activity of the company to be acquired.

III.3. In-group or Overseas Sales

(30) While the turnover is calculated according to paragraph 6 of Article 8 of the Communiqué No 2010/4, turnovers generated from sales among the persons or economic units listed in the first paragraph of the same article will not be included. The aim is to take into account the real economic weight of the parties in the market with respect to the transaction. On the other hand, the overseas sales of the said persons or economic units will be ignored when the turnover in Turkey is calculated.

III.4. Avoiding double counting and allocation of turnover

(31) Double counting should be avoided when the turnovers of the transaction parties are calculated in joint ventures. Therefore, when the joint venture is regarded as an undertaking concerned beside the parent company, the turnover of the parent company will be calculated without the turnover of the joint venture to be acquired and the turnover of the joint venture will be calculated without the turnover of the parent company. For instance when joint venture C is jointly controlled by companies A and B, and company A acquires the entire shares of B; while the turnover of company A is calculated, the turnover of joint venture C will be ignored and while the turnover of C is calculated, the turnover of company A will be ignored.

(32) In accordance with paragraph three of Article 8 of the Communiqué No 2010/4, the principle of avoiding double counting shall be applied where, in a merger or acquisition, undertakings concerned jointly hold the rights and powers listed in subparagraph (b) of paragraph 1 of the same Article over a different person or economic unit. Accordingly, the turnover of the economic unit over which the aforementioned rights and powers are jointly held, generated by its sales to third parties, shall be divided by the number of the undertakings concerned. Consequently, this calculation shall be based not on share percentages but on the number of the shareholders holding the rights or powers listed in subparagraph (b), paragraph 1 of Article 8 of the Communiqué No 2010/4, with the turnover of the economic units of the aforementioned nature divided equally

among the undertakings concerned. For instance, in a transaction where Company A acquires Company B, the turnover of Joint Venture C, which is under joint control of A and B each of which hold half of the voting rights over it, shall be included in the calculation by being divided equally among Companies A and B.

(33) Similarly, in accordance with paragraph 4 of Article 8 of the Communiqué No 2010/4, turnovers of those undertakings over which undertakings concerned hold the right to manage operations jointly with third parties shall be calculated by division with the number of these right-holders.

(34) The aforementioned points may be explained as follows with a figure:

Figure 1.

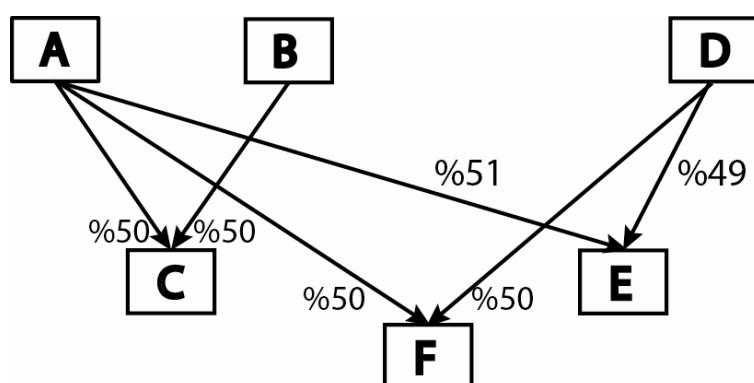

In this figure, A and B refers to the undertakings concerned, while percentage numbers refer to the voting right percentages.

In the figure above:

- The turnover generated by Company C through its sales to companies other than A, B, F and E shall be divided equally among A and B.
- The turnover generated by Company E through its sales to companies other than A, C and F shall be wholly transferred to A.
- The turnover generated by Company F through its sales to companies other than A, C and E shall be divided equally among A and D.

III.5. Transactions between the same persons or parties

(35) Article 8, paragraph 5 of the Communiqué No 2010/4 states that two or more transactions falling under paragraph 2 of the same Article, concluded between the same persons or parties within a period of two years would be treated as a single transaction in terms of the calculation of turnovers as specified in Article 7 of the Communiqué No 2010/4. In case such transactions exceed the notification thresholds individually or cumulatively, all of the transactions must be notified, regardless of whether the transactions concerned are related to the same market or sector or whether they were previously notified. The main goal of this regulation is to prevent the conclusion of important mergers or acquisitions without authorization through the compartmentalization of those mergers and acquisitions originally subject to authorization. For instance in a market where only companies A and B are active and have turnovers of 100 and 50 million TL respectively, the acquisition of B by A is subject to authorization due to turnover thresholds. The acquisition of B's operations in two segments of 25 million TL each in order to remove this transaction from the scope of authorization would allow two transactions to occur, neither of which are apparently subject to authorization; however, in case the aforementioned transactions are concluded within a two-year period they would be assessed together and the turnovers would be integrated. In the example of this transaction, while the turnover threshold is not exceeded when the first segment of B worth 25 million TL is acquired, when the second 25 million TL segment is acquired the relevant turnover amount would include the 25 million TL arising from the first transaction, the total turnover of 50 million TL would be taken into consideration, and the transaction would be subject to authorization.

III.6. Calculation of turnover

(36) Paragraph 1, Article 8 of the Communiqué No 2010/4 specifies specific criteria for identifying the persons or economic units, in addition to undertakings concerned, whose turnovers may be attributed to the parties to the transaction. Accordingly, in the calculation of the turnover, the sum total of the following shall be taken into account.

a) Undertaking concerned,

b) Persons or economic units in which the undertaking concerned

1) holds more than half of the capital or commercial assets, or

2) holds the power to exercise more than half of the voting rights, or

3) holds the power to appoint more than half of the members of the board of supervisors, board of directors or the bodies authorized to represent the undertaking, or

4) holds the power to manage operations,

c) Persons or economic units which hold the rights and powers listed in b) over the undertaking concerned,

ç) Persons or economic units over which those listed in (c) hold the rights and powers listed in (b),

d) Persons or economic units over which those listed in (a-ç) jointly hold the rights and powers listed in (b).

An example is given in the figure below in order to explain which undertakings shall be included in the calculation of the turnover.

Figure 2.

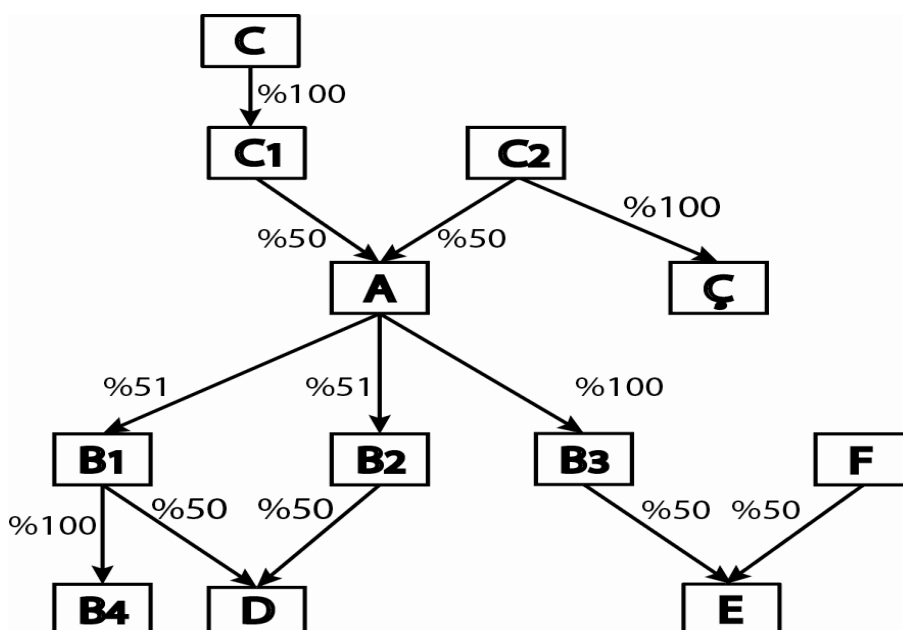

In the Figure, A refers to the undertaking concerned, while percentage numbers refer to the voting right percentages.

- (37) The rights and powers listed in points 1, 2 and 3 of sub-paragraph (b), paragraph 1 of Article 8 of the Communiqué No 2010/4 may be established in a simple and clear manner since they are based on quantitative criteria. These thresholds are met in terms of companies in which the undertaking concerned holds more than half of the capital or commercial assets, holds the power to exercise more than half of the voting rights or is empowered *de jure* to appoint more than half of the members of the board of supervisors, board of directors or the bodies authorized to represent the undertaking. Also, if it is *de facto* possible for the undertaking concerned to exercise more than half of the voting rights in the shareholders' meeting of other companies or to appoint more than half of the members of the bodies authorized to represent other companies, such companies will also be included in the calculation of the turnover.
- (38) The provision in point 4, sub-paragraph (b), paragraph 1 of Article 8 of the Communiqué No 2010/4 refers to the right of undertakings to manage their operations. "*The right to manage operations*" is the right which ensures *de jure* the determination of the strategic behavior of the undertaking. These rights may occur in the form of holding the voting rights or they may arise from contracts such as leasing contracts, etc.
- (39) The right to manage operations also covers the situations where the undertaking concerned holds the right to manage the operations of a company jointly with third parties. Accordingly, even when each of the undertakings with joint control only holds these rights in the negative sense individually, i.e. in terms of veto power, it is accepted that they hold the right to manage the operations of the company controlled. In the above figure, Company E, which is controlled by the undertaking concerned A and the third party F, will be included in the calculation of the turnover as a company whose operations are managed by the undertaking concerned. In accordance with point 4, sub-paragraph (b), paragraph 1 of Article 8 of the Communiqué No 2010/4, in case of *de jure* rights which only grant explicit rights to manage operations to the undertaking concerned and to third parties, such joint ventures shall be taken into account in the calculation of the turnover. Therefore, the inclusion, in the calculation of the turnover, of joint ventures controlled with third parties has been limited to those

cases where the undertaking concerned and third parties hold joint management rights on the basis of an agreement such as a shareholders' agreement or where the undertaking concerned and the third party has equal voting rights, i.e. they can appoint an equal number of members in the decision-making body of the joint venture.

(40) The turnovers of all persons or economic units which hold the rights and powers listed in sub-paragraph (b), paragraph 1 of Article 8 of the Communiqué No 2010/4 over the undertaking concerned must be included in the calculation. In the figure, the two parent companies (C1 and C2) of the undertaking concerned A as well as C, which is the the parent company of C1, will be jointly taken into consideration in the calculation of the turnover.

(41) Persons or economic units in which the undertaking concerned, directly or indirectly, holds the rights and powers listed in sub-paragraph (b), paragraph 1 of Article 8 of the Communiqué No 2010/4 are also taken into account in the calculation of the turnover. In the example figure, companies B1, B2 and B3 where the undertaking concerned A directly holds more than half of the shares, as well as Companies B4 and D, where A indirectly holds more than half of the shares will be included in the calculation of the turnover. Also, in accordance with sub-paragraph (ç), paragraph 1 of Article 8 of the Communiqué No 2010/4, those companies in which the parent company of the undertaking concerned directly or indirectly holds the rights and powers listed in sub-paragraph (b) of the same paragraph will be taken into account in the calculation of the turnover. In the above example, the turnover of Ç, which is a subsidiary of the parent company C2 of the undertaking concerned A will be included in the calculation.

IV. ANCILLARY RESTRAINTS

IV.1. In General

(42) Paragraph 5 of Article 13 of the Communiqué No 2010/4 provides that the authorization granted by the Competition Board concerning the merger and acquisition shall also cover those restraints which are directly related and necessary to the implementation of the transaction, with the principle being the parties to the transaction should determine whether the restraints introduced by the merger or acquisition exceed this framework.

(43) This regulation eliminates the previous practice of assessing ancillary restraints in all concentration transactions and basically leaves the assessment of whether or not a restraint is an ancillary restraint to the responsibility of the parties. Consequently, with the aforementioned regulation of the Communiqué No 2010/4, the adopted and announced principle is that even in the absence of an assessment concerning ancillary restraints in the Competition Board decisions on concentrations, the relevant authorization decision would cover the ancillary restraints as well. However, on the request of the parties, in its decision concerning the concentration the Competition Board shall assess any restraints with a novel aspect, which have not been addressed in the Guidelines herein or in its previous decisions.

(44) It is not possible to apply Articles 4 and 6 of the Act No 4054 on the Protection of Competition to ancillary restraints. However, any limitation that does not carry the characteristics of an ancillary restraint may be assessed within the framework of Articles 4, 5 and 6 of the Act No 4054 on the Protection of Competition.

IV.2. The concept of ancillary restraints

(45) Ancillary restraints are those which are directly related to the concentration and which are necessary to the implementation of the transaction and to fully achieving the efficiencies expected from the concentration.

(46) The criteria of "direct relation" and "necessity" will be assessed objectively in accordance with the specifics of the case.

(47) For the restraints to be directly related, it is not sufficient for them to be implemented within the same scope or time period with the concentration transaction; in addition, they have to be closely related economically to the main transaction and they have to be envisaged for a smooth transition to the new structure to be formed following the concentration.

(48) The criterion of necessity, on the other hand, may be fulfilled in case the relevant restraint is obligatory for the implementation of the concentration or in case of a significant increase in uncertainty and costs of the main transaction in the absence of the restraint. In establishing whether a restraint is necessary, the

duration and scope of the restraint shall be taken into consideration, in addition to its nature. On the other hand, the restraint with the least restriction on competition must be preferred among alternative restraints that serve to attain the same goal.

IV.3. General principles concerning application

- (49) In acquisitions, in order to ensure that the value of the right or asset acquired is fully transferred to the buyer, the seller might have to be placed under an obligation not to compete with the buyer for a certain period. This requirement may come up particularly in relation to building up a clientèle and sufficiently exploiting the *know-how* acquired.
- (50) In order for the non-competition obligation placed on the seller to be accepted as an ancillary restraint, its scope in terms of duration, subject, geographic area and persons must not exceed the reasonably necessary level.
- (51) Non-competition obligations that do not exceed three years in terms of their duration are generally accepted as reasonable. However, it may be possible to accept under the framework of ancillary restraints non-competition obligations with a duration longer than three years, in case customer tie-in lasts longer or it is required by the nature of the *know-how* transferred, provided that the scale required by the concrete case is not exceeded¹. On the other hand, in joint ventures, long-term or indefinite non-competition obligations preventing the parent undertakings from competing with the joint venture may be accepted as ancillary restraints.
- (52) As a rule, non-competition obligations must be limited to those goods and services comprising the area of operation of the economic unit to be acquired before the transaction. Goods and services which have mostly completed development phase but not yet entered marketing phase may be included within this framework.
- (53) Similarly, non-competition obligations must be limited geographically to the area of operation of the seller before the transaction. However, in exceptional circumstances such as when the seller has made investments to enter into new

regions, restraints concerning these regions may also be accepted as necessary and reasonable.

(54) Restraints concerning the seller itself and those economic units and agencies which constitute an economic unit with the seller may be accepted as reasonable, while any non-competition obligations beyond them, especially those concerning the dealers of the seller or users, shall not be accepted as necessary and related restraints.

(55) Any obligation similar to or complementary with non-competition obligations such as those preventing the seller from employing the workers of the undertaking to be acquired and from disclosing or using the trade secrets of the undertaking to be acquired shall be assessed in a manner similar to non-competition obligations. Such that, where confidentiality is related to the *know-how*, an obligation to prevent the disclosure and utilization of the relevant information as long as it stays confidential, i.e. retains its *know-how* characteristics, may be assessed as an essential element of the transaction.

¹ For instance, see Competition Board decisions dated 24.11.2005 and numbered 05-79/1088-314, dated 14.8.2008 and numbered 08-50/741-297, dated 15.4.2009 and numbered 09-15/343-85.