



**OFFICE FOR HARMONIZATION IN THE INTERNAL MARKET
(TRADE MARKS AND DESIGNS)**

The President

**DECISION No EX-15-2 OF THE PRESIDENT OF THE OFFICE
of 8 July 2015**

**adopting the Guidelines for Examination in the Office for Harmonization in the
Internal Market (Trade Marks and Designs) on Community Trade Marks and on
Registered Community Designs**

THE PRESIDENT OF THE OFFICE FOR HARMONIZATION IN THE INTERNAL
MARKET (TRADE MARKS AND DESIGNS),

Having regard to Council Regulation (EC) No 207/2009 of 26 February 2009 on the
Community trade mark ("CTMR"), in particular Article 124 (2) (a) thereof, and to
Council Regulation (EC) No 6/2002 of 12 December 2001 on Community designs
("CDR"), in particular Article 100 thereof,

After consultation of the Administrative Board in accordance with Article 126 (4) CTMR
and Article 101 (b) CDR,

HAS ADOPTED THE FOLLOWING DECISION:

Article 1

The following Guidelines for Examination in the Office for Harmonization in the Internal
Market (Trade Marks and Designs) on Community Trade Marks and on Registered
Community Designs which are annexed to this Decision are hereby adopted:

New Parts of the Guidelines:

A) COMMUNITY TRADE MARK:

Part A: General Rules

Section 1, Means of communication, Time limits

Section 2, General principles to be respected in proceedings

Section 4, Language of Proceedings

Section 6, Revocation of Decisions, Cancellation of Entries in the Register and
Correction of Errors

Section 7, Revision

Section 8, Restitutio in Integrum

Section 9, Enlargement

Part B: Examination

Section 1, Proceedings

Section 3, Classification

Section 4, Absolute Grounds for Refusal [7(1)(f)(g)(h)(i)(j)(k), Collective marks]

Part C: Opposition

Section 3, Unauthorised Filing by Agents of the TM Proprietor (Article 8(3) CTMR)

Section 4, Rights under Article 8(4) CTMR
Section 5, Trade Marks with reputation Article 8(5) CTMR

Part D: Cancellation
Section 2, Substantive Provisions

Part E: Register Operations
Section 1, Changes in a Registration
Section 3, CTMs as objects of property
Chapter 1, Transfer
Chapter 2, Licences
Chapter 3, Rights in Rem
Chapter 4, Levy of Execution
Chapter 5, Insolvency proceedings or similar proceedings

Part M: International marks

B) REGISTERED COMMUNITY DESIGN:

Examination of Applications for Registered Community Designs
Renewal of Registered Community Designs

Article 2

The Office Practice contained in the previous Guidelines on Trade Mark Practice and on Designs and to the extent as it corresponds to the Parts as referred to in Article 1 is hereby repealed.

Article 3

The Guidelines referred to in Article 1 shall be published in the Official Journal of the Office.

Article 4

This Decision shall be published in the Official Journal of the Office and enter into force on the 01/08/2015.

Done at Alicante, 8 July 2015



António Campinos
President

***GUIDELINES FOR EXAMINATION IN THE
OFFICE FOR HARMONIZATION IN THE
INTERNAL MARKET (TRADE MARKS AND
DESIGNS) ON COMMUNITY TRADE MARKS***

PART A

GENERAL RULES

SECTION 1

MEANS OF COMMUNICATION, TIME LIMITS

Table of Contents

1	Introduction.....	3
2	Procedures for Filing and for Communication with the Office.....	3
3	Notification and Communication of Documents.....	3
3.1	Communication to the Office.....	4
3.1.1	By telecopier (fax).....	4
3.1.2	By electronic means	5
3.1.3	By post, courier service or personal delivery.....	5
3.2	Notification by the Office	5
3.2.1	Notification by telecopier	6
3.2.2	Notification by post	6
3.2.3	Notification by deposit in a post box at the Office	7
3.2.4	Notification by hand delivery.....	7
3.2.5	Notification via the Office’s official website.....	7
3.2.6	Notification by public notification	7
3.3	Addressees	8
4	Time Limits.....	8
4.1	Time limits specified by the Office.....	8
4.1.1	Length of the time limits specified by the Office	9
4.1.2	Expiry of time limits.....	9
4.1.3	Extension of time limits.....	10
4.1.4	Continuation of proceedings.....	11
4.1.5	<i>Restitutio in integrum</i>	12

1 Introduction

This part of the Guidelines includes those provisions that are common to all proceedings before the Office in trade mark matters, except appeals.

In the interests of efficiency and in order to prevent parties encountering different practices, the Office applies procedural rules consistently.

Proceedings before the Office can be classified into two broad types: *ex parte* proceedings, which involve only one party, or *inter partes* proceedings, in which two or more parties are in conflict.

The first category comprises, in particular, applications for registration or renewal of a Community trade mark, transfer-related entries in the Register, licences, levy of execution or bankruptcy, and seniority and conversion proceedings.

The second category includes opposition proceedings and cancellation proceedings (revocation or declaration of invalidity of a registered Community trade mark).

2 Procedures for Filing and for Communication with the Office

Article 25 CTMR Rule 79 and Rule 83 CTMIR
--

An application for a Community trade mark (CTM) may be filed directly with the Office or through a national office of a Member State of the European Union, including the Benelux Trade Mark Office.

All other documents may only be filed directly with the Office.

All documents may be sent to the Office by post or courier services, handed in personally at the Office's reception desk (Avenida de Europa, 4, 03008 Alicante) during Office opening hours (Monday to Friday, 08:30 – 13:30 and 15:00 – 17:00), or sent by fax. Applications for CTMs, oppositions and renewals may also be filed electronically via the Office's official website. As part of its e-business strategy, the Office will progressively make electronic communication available for filing other documents in all types of proceedings.

The Office has made various forms available to the public, in all the official languages of the EU. With one exception, their use is not mandatory but strongly recommended. The exception is when filing an international application or subsequent designation under the Madrid Protocol, for which either the World Intellectual Property Organization's (WIPO) MM 2 or MM 4 or the Office's EM 2 or EM 4 form must be used. All these forms can be downloaded from the Office's official website.

3 Notification and Communication of Documents

The CTMIR distinguishes between documents originating from the parties and addressed to the Office and notifications issued by the Office.

A document's date of notification or communication is the date on which that document is **received or is deemed to be received** by the addressee (including the Office) (judgment of 30/01/2014, C-324/13 P, 'Patricia Rocha', para. 43). Exactly when receipt is deemed to have taken place will depend on the method of notification or communication.

3.1 Communication to the Office

Rule 5(1), Rule 79, Rule 79a, and Rules 80 and 82 CTMIR
Decision No EX-13-02 of the President of the Office

3.1.1 By telecopier (fax)

Where a document is faxed to the Office, the original should be signed so that the fax received by the Office bears the facsimile of the signature. If the fax is not signed, the Office will invite the party concerned to do so within a specified deadline. If the document is not signed within that time, the application or request will be declared inadmissible, or the document will not be taken into account, as the case may be.

However, if the fax was generated electronically by computer ('electronic fax'), the indication of the name of the sender is deemed to be equivalent to the signature.

It is not necessary to follow this up with a confirmation of the fax by mail.

The Office will acknowledge receipt of a fax only in the cases expressly specified by the CTMIR, namely when a CTM application is filed. However, if the communication is incomplete or illegible, or the Office has reasonable doubts as to the accuracy of the transmission, it will advise the sender and invite it to retransmit the communication by fax or to submit a signed original of the document in question to the Office by post, personal delivery or any other means within a specified deadline. If the retransmission is complete, the date of receipt will be considered to be the date of the first transmission, except for the purposes of establishing a filing date for a CTM application. Otherwise, the Office will not take the transmission into account or will consider only the received and/or legible parts (decision of 04/07/2012, R 2305/2010-4 – 'Houbigant/PARFUMS HOUBIGANT PARIS et al.').

For further information on the filing date, see the Guidelines, Part B, Examination, Section 2, Formalities.

Where a document in colour is to be transmitted, the document can be sent by fax and the coloured original filed within one additional month unless provided otherwise by the CTMR. In this case, the date of receipt of the coloured original is deemed to be the date the Office receives the fax, including for the purposes of obtaining a filing date for a CTM application. The time of receipt is the local time in Alicante (Spain) at which the Office received the fax.

3.1.2 By electronic means

In accordance with Rule 82 CTMIR, if a CTM application is filed using e-filing, or a communication is sent to the Office by any electronic means, the indication of the name of the sender is deemed to be equivalent to the signature.

The Decision of the President of the Office is decisive in determining whether, to what extent and under what technical conditions, communications may be sent to the Office by electronic means. Particular reference is made to Decision No EX-13-2, according to which the time of receipt of requests, communications or documents submitted electronically via the official OHIM website is the local time in Alicante (Spain) when such receipt was validated.

Where an electronic communication is incomplete or illegible, or the Office has reasonable doubts as to the accuracy of the transmission, Rule 80(2) CTMIR applies *mutatis mutandis*.

3.1.3 By post, courier service or personal delivery

Documents sent by post, courier service or personal delivery should be addressed to the Office at the address indicated in the explanatory notes accompanying the forms provided by the Office.

Documents sent by post, courier service or personal delivery must bear an original signature. If a document sent to the Office is not signed, the Office will invite the party concerned to do so within a specific deadline. If the document is not signed within that time, the application or request will be declared inadmissible, or the document will not be taken into account, as the case may be.

The date of receipt is the date on which the Office receives the communication. The time of receipt is the local time in Alicante (Spain).

For further information on copies of the documents submitted, see the Guidelines, Part C, Opposition, Section 1, Procedural matters, 4.2 Substantiation.

3.2 Notification by the Office

Rules 55, 61-69 CTMIR Decision No EX-97-1 of the President of the Office Decision No EX-05-6 of the President of the Office Decision No EX-13-2 of the President of the Office

Written communications from the Office to the party or parties to proceedings will be 'notified'. A document is considered to be **notified** when it has been received or is deemed to have been received by the addressee, irrespective of whether the addressee has been advised of this. Consequently, the date of notification of a document is the date on which that document is **made accessible to or has reached the addressee** and not the date on which it was sent or the date on which the person to whom it was addressed actually learned of the notification. However, exactly when receipt is deemed to take place will depend on the method of notification.

The Office can freely choose the most appropriate means of notification (Rule 61(3) CTMIR), apart from public notification, although some means of notification require the party's prior consent.

In practice, wherever feasible and provided that the number of pages to be transmitted is not excessively high, the Office will always opt for notification by electronic means, if available.

If the proper notification procedure has been followed, the document is deemed to have been notified unless the recipient can prove that it either did not receive the document at all, or received it late. If this is proved, the Office will re-notify the document(s) (judgment of 13/01/2011, T-28/09, 'Pine Tree', para. 32). Conversely, where the proper notification procedure was not followed, the document will still be considered notified if the Office can prove that the document actually reached the recipient.

Any communication or notification from the Office shall indicate the department or division of the Office and the name(s) of the official(s) responsible. These documents have to be signed by the official(s) or, if not, bear the Office's printed or stamped seal. For documents transmitted by telecopier, additional information is provided under paragraph 3.2.1 below.

3.2.1 Notification by telecopier

The Office may use notification by telecopier if the party has indicated a fax number, the exception being notifications that include colour elements.

Notification will be deemed to have taken place on the date on which the recipient's telecopier receives it. The Office keeps fax logs so that it can prove the transmission time and content. In the absence of any evidence to the contrary or information that casts doubt on the correct transmission of the notification, the date of receipt of a fax may be established by the Office transmission report (judgment of 13/01/2011, T-28/09, 'Pine Tree', para. 32).

Where documents are transmitted by telecopier, according to Decision No EX-97-1 of the President of the Office, the name of the department or division stated in the letterhead, together with the name of the official(s) indicated at the end of the document, is considered sufficient identification.

3.2.2 Notification by post

The procedure for notification by post will depend on the nature of the document notified.

If the addressee has a place of business or domicile within the EU or has appointed a professional representative (as defined in the Guidelines, Part A, General Rules, Section 5, Professional Representation), decisions subject to a deadline for appeal, summonses and other documents as determined by the President of the Office will be notified by registered post with recorded delivery.

Where the recipient's address is not in the EU or the addressee has not appointed a professional representative, or for any other document to be notified, the Office will send the document by post.

Notification will be deemed to have taken place 10 days after the document was posted. The recipient can only rebut this presumption by proving that it did not receive the document or that it received it later. Indications giving rise to reasonable doubt about correct receipt are considered to be sufficient proof (judgment of 25/10/2012, T-191/11, 'Miura', para. 34). In the event of a dispute, the Office must establish that the notification reached its destination or establish the date on which it was delivered to the addressee.

Notification by registered letter will be deemed to have been effected even if the addressee refuses to accept the letter.

3.2.3 Notification by deposit in a post box at the Office

The Office may notify addressees who maintain a post box at the Office by depositing the notified document therein. The date of deposit will be recorded by the Office.

Notification will be deemed to take place five days after the document has been deposited.

3.2.4 Notification by hand delivery

The Office may also notify the addressee by delivering the document by hand if the addressee is present at the Office in person, but this method of notification is an exception. A copy of the document showing a signed and dated acknowledgement of receipt by the addressee will be kept in the file.

3.2.5 Notification via the Office's official website

Pursuant to Decision No EX-13-2 of the President of the Office of 26/11/2013, notification may also be made via the Office's official website if the holder of an electronic account with the Office has accepted this means of notification. In this case, notification consists of placing the electronic document in the holder's inbox. This date will be indicated in the holder's inbox and will be recorded by the Office (decision of 17/01/2011, R 0956/2010-4 – 'DURAMAXX/DURAMAX').

The document is deemed to have been notified five days after being placed in the holder's inbox irrespective of whether the recipient actually opened and read it (Article 4(4) of the Decision of the President EX-13-2).

3.2.6 Notification by public notification

Public notification will be used for all notifications where the addressee's address is unknown or where a notification by post has been returned to the Office after at least one failed attempt.

This relates primarily to post returned to the Office by the Post Office marked 'not known at this address' and post that has not been claimed by the addressee.

Public notifications will be published on the Office's website. The document will be deemed to have been notified one month after the day on which it was posted on the internet.

3.3 Addressees

Rules 67 and 77 CTMIR Articles 92 and 93 CTMR
--

If a professional representative has been duly appointed, the Office will send all notifications to the representative (judgments of 12/07/2012, T-279/09, '100% Capri', and of 25/04/2012, T-326/11, 'BrainLAB'). 'Duly appointed' means that the representative is entitled to act as such and has been properly appointed, and that no general obstacle exists to preclude representation by that person, such as illicit representation of both parties in an *inter partes* proceeding. Filing an authorisation is not required in order to receive Office notifications. For further details see the Guidelines, Part A, General Rules, Section 5, Professional Representation.

Any notification addressed to the representative will have the same effect as if it had been addressed to the person represented. Similarly, any communication addressed to the Office by a representative will be considered to have originated from the person it represents.

4 Time Limits

Rules 70-72 CTMIR

Time limits before the Office can be divided into two categories:

- those laid down by the CTMR or CTMIR, which are therefore mandatory;
- those specified by the Office, which are therefore not mandatory and can be extended under certain circumstances.

4.1 Time limits specified by the Office

Time limits are an essential tool for conducting orderly and reasonably swift proceedings. They are a matter of public policy and rigorous compliance with them is necessary to ensure clarity and legal certainty.

The Regulations foresee three measures that mitigate the rigorous application of the principle of strict observance of time limits (deadlines), depending on whether they are still running or have expired.

If the time limit is still running, the party may *request an extension* of the time limit pursuant to Rule 71(1) CTMIR.

If the time limit has expired, the party who has missed it still has two possible courses of action: it can either seek *continuation of proceedings* (pursuant to Article 82 CTMR),

which only requires meeting certain formal requirements, or it can request *restitutio in integrum* (pursuant to Article 81 CTMR), which requires meeting formal and substantive requirements (such as showing all due care).

Additional information is provided under paragraphs 4.1.4 and 4.1.5 below.

4.1.1 Length of the time limits specified by the Office

With the exception of the time limits expressly specified in the CTMR or CTMIR, the time limits specified by the Office, when the party concerned has its domicile or its principal place of business or an establishment within the European Union, may not be less than one month or longer than six months. When the party concerned does not have its domicile or principal place of business or an establishment within the EU, the time limits may not be less than two months or longer than six months. The general practice is to grant two months.

For further information, see the Guidelines, Part A, General Rules, Section 5, Professional Representation.

4.1.2 Expiry of time limits

Where the Office sets a time limit in a notification, the 'relevant event' is the date on which the document is notified or deemed notified, depending on the rules governing the means of notification.

Where a time limit is expressed in months, it will expire in the relevant subsequent month on the same day as the day on which the 'relevant event' occurred.

For example, if the Office sets a two-month time limit in a communication which is notified by fax on 28 June, the time limit will expire on 28 August. It is immaterial whether the 'relevant event' occurred on a working day, a holiday or a Sunday; that is relevant only for the expiry of the time limit.

Where the relevant subsequent month has no day with the same number or where the day on which the event occurred was the last day of the month, the time limit in question will expire on the last day of that month. A two-month time limit specified in a notification on 31 July will therefore expire on 30 September. Similarly, a two-month time limit set in a notification on 30 June will expire on 31 August.

Any time limit will be deemed to expire at midnight on the final day (local time in Alicante (Spain)).

A time limit that expires on a day on which the Office is not open for receipt of documents or on which ordinary post is not delivered in the locality in which the Office is located (Saturdays, Sundays and public holidays) will be extended to the first working day thereafter. For this purpose, the President of the Office determines the days on which the Office is closed before the start of each calendar year. The extension is automatic but it applies only at the end of the time limit (decision of 12/05/2011, R 0924/2010-1 – 'whisper power-WHISPER').

In the event of a general interruption to the postal service in Spain or to the Office's connection to authorised electronic means of communication, any time limit that

expires during that period will be extended to the first working day after the period of interruption. These periods will be determined by the President of the Office; the extension will apply to all parties to the proceedings.

In the event of an exceptional occurrence (strike, natural disaster, etc.) causing a disruption to the running of the Office or a serious impediment to its communication with the outside world, time limits may be extended for a period determined by the President of the Office.

4.1.3 Extension of time limits

An extension of the time limits may be granted if the party concerned makes the request before the original time limit expires.

In **ex parte proceedings** before the Office, if a request is made for an extension before the time limit expires, then a further period should be allowed, depending on the circumstances of the case, but not exceeding six months.

For the rules applicable to the extension of time limits in **inter partes proceedings** (i.e. where there are two or more parties involved, such as in opposition, invalidity and/or revocation proceedings), see the Guidelines, Part C, Opposition, Section 1, Procedural Matters.

Unless otherwise provided for either in the Regulations or in the specific paragraphs in this Guideline, as a general rule any initial request for an extension that is received in time will always be granted, irrespective of the explanation given by the party requesting it. However, any subsequent request for an extension of the same time limit will be refused unless the party requesting it can explain and justify the 'exceptional circumstances' that (a) prevented it from carrying out the required action during the previous two periods (i.e. the original time limit plus the first extension) and (b) still prevent the requester from carrying it out, so that more time is needed.

Examples of justifications that can be accepted:

- 'Evidence is being gathered from distribution channels/all our licensees/our suppliers in several Member States. So far, we have gathered documents from some of them but, due to the commercial structure of the company (as shown in the document enclosed), we have only recently been able to contact the rest'.
- 'In order to show that the mark has acquired distinctiveness through use we started carrying out market research at the beginning of the period (on date X). However, the fieldwork has only recently been concluded (as shown in the enclosed documents); consequently, we need a second extension in order to finish the analysis and prepare our submissions to the Office.'
- 'Death' is also considered an 'exceptional circumstance'. The same applies to serious illness, provided that no reasonable substitution was available.
- Finally, 'exceptional circumstances' also include 'force majeure' situations. 'Force majeure' is defined as a natural and unavoidable catastrophe that interrupts the expected course of events. It includes natural disasters, wars and terrorism, and unavoidable events that are beyond the party's control.

Where a request is filed for an extension to an extendible time limit before this time limit expires and is not accepted, the party concerned will be granted at least one day to meet the deadline, even if the request for an extension arrives on the last day of the time limit.

4.1.4 Continuation of proceedings

Article 82 CTMR Communication No 06/05 of the President of the Office
--

The expressions 'further processing' and 'continuation of proceedings' have the same meaning.

Article 82 CTMR provides for the continuation of proceedings where time limits have been missed but excludes various time limits laid down in certain articles of the CTMR and CTMIR. Communication No 06/05 of the President of the Office of 16/09/2005 on restoration into missed time limits indicates that, with a few exceptions, most of these exclusions are self-explanatory.

The excluded time limits are the following:

- Those laid down in Article 81 CTMR, avoiding double relief for the same time limits;
- Those referred to in Article 112 CTMR, i.e. the three-month period within which conversion must be requested and the conversion fee paid;
- The opposition period and the time limit for paying the opposition fee laid down in Article 41 CTMR;

Those laid down in Article 42 CTMR, i.e. the time limits set by the Office for the parties to submit observations within the opposition procedure. This covers the time limits for the opponent to substantiate its opposition under Rule 19 CTMIR, the time limit laid down in Rule 20(2) CTMIR for the applicant to reply, the time limit under Rule 20(4) CTMIR for the opponent to rebut and the time limits for any further exchange of arguments, if allowed by the Office (decision of 07/12/2011, R 2463/2010-1 – 'Pierre Robert/Pierre Robert').

Pursuant to Rule 50(1), 2nd sentence CTMIR, these (or the corresponding) time limits shall not be applicable in second instance proceedings before the Boards of Appeal.

None of the other time limits during the opposition procedure are referred to in Article 42 CTMR and, therefore, they are not excluded from further processing. Consequently, the Office will grant further processing for:

- the time limit under Article 119(6) CTMR and Rule 16(1) CTMIR to translate the notice of opposition;
- the time limit under Rule 17(4) CTMIR to remedy deficiencies that affect the admissibility of the opposition;

- the time limit under Rule 22(1) CTMIR for the applicant to request that the opponent prove use of its earlier mark;
- the time limit under Rule 22(2) CTMIR for the opponent to submit proof of use of its earlier mark;
- the time limit under Rule 22(6) CTMIR to translate proof of use.
- Those laid down in Article 25(3), Article 27, Articles 29(1), 33(1), 36(2) and 47(3), Articles 60 and 62, Article 65(5) and Article 82, and the time limits laid down by the CTMIR for claiming, after the application has been filed, priority within the meaning of Article 30, exhibition priority within the meaning of Article 33 or seniority within the meaning of Article 34.

Article 82 CTMR does not exclude any of the time limits that apply in proceedings for revocation or declaration of invalidity.

The party seeking continuation of proceedings must make the request, for which a fee is charged as established in the CTMFR, within two months of the expiry of the original time limit and complete the omitted act by the time the request for continuation is received.

There can be no extension or continuation of the two-month deadline. There is no substantive requirement to be fulfilled such as when requesting *restitutio in integrum*.

4.1.5 *Restitutio in integrum*

A party to proceedings before the Office may be reinstated in its rights (*restitutio in integrum*) if, in spite of all due care required by the circumstances having been taken, it was unable to meet a time limit vis-à-vis the Office, provided that the failure to meet the time limit had the direct consequence, by virtue of the provisions of the Regulations, of causing the loss of any right or means of redress.

For further information see the Guidelines, Part A, General Rules, Section 8, *Restitutio in Integrum*.

***GUIDELINES FOR EXAMINATION IN THE
OFFICE FOR HARMONIZATION IN THE
INTERNAL MARKET (TRADE MARKS AND
DESIGNS) ON COMMUNITY TRADE MARKS***

PART A

GENERAL RULES

SECTION 2

***GENERAL PRINCIPLES TO BE RESPECTED
IN PROCEEDINGS***

Table of Contents

1	Adequate Reasoning	3
2	The Right to Be Heard	3
3	General Principles of EU Law	4
4	Means of Taking Evidence	5
4.1	Written evidence	6
4.2	Oral evidence	6
4.3	Specific means of evidence	6
4.3.1	Commissioning of experts by the Office	6
4.3.2	Affidavits	7
4.3.3	Inspections	8
4.4	Costs of taking evidence	8
5	Oral Proceedings	8
5.1	Opening of oral proceedings	8
5.2	Course of the oral proceedings	9
5.3	Minutes of evidence and of oral proceedings	10
6	Decisions	10
6.1	Contents	10
6.2	Apportionment of costs	10

Articles 75-78 and 85 CTMR

1 Adequate Reasoning

Office decisions shall be in writing and shall state the reasons on which they are based. The reason for this is twofold: to explain to interested parties why the measure was taken so that they can protect their rights and to enable the Courts of the European Union to exercise their power to review the legality of the decision (judgments of 12/07/2012, T-389/11, 'Guddy', para. 16 and of 22/05/2012, T-585/10, 'Penteo', para. 37, as well as the case-law cited).

However, if the Office does not respond to all the arguments raised by the parties, this does not infringe the duty to state reasons.

It is sufficient that it sets out the facts and the legal considerations of fundamental importance in the context of the decision (see, among others, judgments of 18/01/2013, T-137/12, 'Vibrator', paras 41 and 42; of 20/02/2013, T-378/11, 'Medinet', para. 17; of 03/07/2013, T-236/12, 'Neo', paras 57 and 58; of 16/05/2012, T-580/10, 'Kindertraum', para. 28; or judgment of 10/10/2012, T-569/10, 'Bimbo Doughnuts', paras 42-46, confirmed by judgment of 08/05/2014, C-591/12 P).

2 The Right to Be Heard

In accordance with the general principle of the right of defence, a person whose interests are affected by a decision taken by a public authority must be given the opportunity to express their point of view. Therefore, in all proceedings before the Office, the parties will always have the opportunity to state their positions and to put forward their grounds of defence.

Decisions will only be based on reasons or evidence on which the parties have had an opportunity to present their comments. The right of defence therefore requires a communication to be received (judgment of 25/10/2012, T-191/11, 'Miura', para. 25).

The right to be heard covers all the matters of fact or law, together with the evidence that forms the basis for the decision. However, the right to be heard does not apply to the final position that is going to be adopted. Therefore, the Office is not bound to inform the parties of its legal opinion before issuing a decision and to afford them the opportunity to submit their observations on that position, or even to submit additional evidence (see, among others, judgments of 14/06/2012, T-293/10, 'Colour per se', para. 46 *in fine*; of 08/03/2012, T-298/10, 'Biodanza', para. 101; and judgment of 20/03/2013, T-277/12, 'Caffè Kimbo', paras 45 and 46).

The Office will examine the facts in proceedings before it on its own initiative, although in proceedings relating to relative grounds for refusal it will restrict this examination to the facts, evidence and arguments provided by the parties (this also applies to cancellation proceedings).

This restriction does not prevent the Office from taking into consideration, in addition to the facts expressly put forward by the parties, facts that are well known, that is, those that are likely to be known by anyone or that may be learnt from generally accessible sources or those arising from practical experience generally acquired from marketing general consumer goods that are likely to be known by anyone and are in particular

known by the consumers of those goods. Therefore, the Office can use facts that are a matter of common knowledge as a basis for its reasoning.

The Office is not required to prove the accuracy of these well-known facts and, therefore, it is not obliged to give examples of such practical experience; it is up to the party concerned to submit evidence to refute it (see, among others, judgment of 20/03/2013, T-277/12, 'Caffè Kimbo', para. 46; judgment of 11/07/2013, T-208/12, 'Rote Schnürsenkelenden', para. 24; judgment of 21/02/2013, T-427/11, 'Bioderma', paras 19-22; judgment of 08/02/2013, T-33/12, 'Medigym', paras 20 and 25; judgment of 07/12/2012, T-42/09, 'Quadratum', para. 73; and judgment of 19/09/2012, T-231/11, 'Stoffmuster', para. 51).

However, in *ex parte* proceedings when the Office, on its own initiative, assembles facts that are not well known and that are intended to serve as the basis for its decision, it is under an obligation to notify the party of those facts in order that the party may submit its views thereon.

If documents are filed or allegations are made after a deadline set by the Office has expired, these will in principle be considered to be late and the document will not be taken into account. For more details, see the Guidelines, Part C, Opposition, Section 1, Procedural matters, 4.5.1 Additional evidence for proof of use and the Guidelines, Part C, Opposition, Section 6, Proof of use, 3.3.1 Time limit for providing proof of use.

However, the Office will take legal issues into account, irrespective of whether or not they have been pleaded by the parties.

Changing circumstances arising in the course of the proceedings will also be taken into account. For example, if during opposition proceedings the earlier right on which the opposition was based lapses (e.g. it is not renewed or is declared invalid), this will always be taken into account.

3 General Principles of EU Law

The Office must respect the general principles of EU law, such as equal treatment and sound administration (see, among others, judgment of 24/01/2012, T-260/08, 'Visual Map'; judgment of 23/01/2014, T-68/13, 'Care to care', para. 51; and judgment of 10/03/2011, C-51/10 P, '1000', para. 73).

For reasons of legal certainty and of sound administration, there must be a stringent and full examination of all trade mark applications in order to prevent trade marks from being improperly registered. That examination must be undertaken in each individual case.

The lawfulness of the Office's decisions must be assessed solely on the basis of Community regulations, as interpreted by the European Union judicature. Accordingly, OHIM is not bound either by its previous decision-making practice or by a decision given in a Member State, or indeed a third country, that the sign in question is registrable as a national mark. This is the case even if such a decision was adopted in a country belonging to the linguistic area in which the word sign in question originated (judgment of 16/05/2013, T-356/11, 'Equipment', para. 7).

However, in the light of the principles of equal treatment and sound administration, OHIM will take into account the decisions already taken in respect of similar applications and must carefully consider whether it should decide in the same way or not (judgment of 10/03/2011, C-51/10, '1000', paras 74-75; judgment of 27/02/2014, T-225/12, 'LIDL express', para 56; judgment of 23/01/2014, T-68/13, 'Care to care', para. 51; and judgment of 12/12/2013, T-156/12, 'Oval', para. 28).

Moreover, the principle of equal treatment and sound administration must be applied in a manner that is consistent with the principle of legality, according to which a person may not rely, in support of its claim, on an unlawful act committed in another procedure (judgment of 23/01/2014, T-68/13, 'Care to care', para. 51; judgment of 12/12/2013, T-156/12, 'Oval', para. 29; judgment of 02/05/2012, T-435/11, 'UniversalPHOLED', para. 38; and judgment of 10/03/2011, C-51/10, '1000', paras 76-77).

4 Means of Taking Evidence

Articles 77 and 78 CTMR
Rules 56-60 CTMIR
Decision No EX-99-1 as amended by Decision No EX-03-2 of 20/1/2003

In any proceedings before the Office, evidence may be taken. The means for taking evidence are listed in Article 78 CTMR and Rule 57 CTMIR, although that list is not exhaustive.

The means of evidence are as follows:

- hearing the parties
- requests for information
- the production of documents and items of evidence
- hearing witnesses
- opinions by experts
- sworn or affirmed statements in writing or statements having a similar effect under the law of the State in which they are drawn up
- inspection.

Some of these means, such as requests for information, statements in writing and, in particular, the submission of documents and items of evidence, will be used more frequently than others. Hearing the parties, witnesses or experts, and inspections are used only exceptionally.

The Office will decide which of these means to use but will use them only when necessary for examining the file.

If the Office refuses a request to take evidence, an appeal can only be made together with the appeal against the final decision.

The procedure followed by the Office varies depending on the means of taking evidence proposed.

4.1 Written evidence

When taking evidence, the Office will confine itself to written evidence in most cases. This is the least costly, simplest and most flexible means of taking evidence.

The Office will therefore give preference to the submission of documents and items of evidence. However, other possible written means of taking evidence include not only a request for information or statements in writing that have been sworn or affirmed or have a similar effect thereto under the law of the State in which they are drawn up, but also opinions by experts, which may consist solely of a written report.

The Regulation makes no provision for any special procedure or formality. Therefore, the Office's general rules of procedure apply.

Any information, documents or items of evidence submitted by one party will be communicated to the other parties as soon as possible, and the Office may set the other parties a time limit of, in principle, two months to reply.

The Office will base its decision only on reasons on which both sides have had an opportunity to submit observations.

For further information on Oral Proceedings, see paragraph 5 below.

4.2 Oral evidence

This refers to evidence taken in oral proceedings, such as hearing the oral evidence of parties, witnesses or experts.

Only in exceptional cases will the Office decide to hear oral evidence, in particular because of the cumbersome nature of the procedure, which is liable to protract the proceedings, and because of the cost, which will have to be borne by the unsuccessful party in *inter partes* proceedings, or in some cases by both parties.

If the Office invites one of the parties to give evidence orally, it will advise the other parties accordingly so that they can attend.

Similarly, when the Office summons an expert or a witness to a hearing, it will advise the parties concerned. These may be present and put questions to the person giving evidence.

4.3 Specific means of evidence

4.3.1 Commissioning of experts by the Office

Opinions by experts will be used only as a last resort because they involve substantial costs and protract the proceedings.

It is up to the Office to decide whether or not to commission an expert's opinion and who to appoint as expert. However, the Office does not maintain a list of experts because it uses experts as a means of taking evidence only by way of exception.

The terms of reference of the expert include:

- a precise description of their task
- the deadline for submitting their report
- the names of the parties to the proceedings
- details of any costs to be reimbursed by the Office.

On receipt of the expert's report, the Office will forward copies to the parties.

If the Office considers the report sufficient, and if the parties accept this form of report, it will in principle be used only in its written form.

The submission of an oral report or the hearing of oral evidence given by the expert will therefore be at the Office's discretion.

The parties can object to an expert on the grounds of incompetence or a conflict of interest, or because the expert was previously involved in the dispute or is suspected of partiality. No refusal may be based on the appointed expert's nationality. If a party objects to the expert, the Office will rule on the objection. The grounds that may be cited for objecting to an expert are the same as those for objecting to an examiner or Board of Appeal member pursuant to Article 137 CTMR.

4.3.2 Affidavits

Sworn or affirmed statements in writing or statements having a similar effect under the law of the State in which the statement is drawn up are equally admissible as evidence, if provided by a party.

In order for a statement to be considered sworn or affirmed, it must be understood by the parties that making a false statement would be considered a criminal offence under the law of the Member State in which the document was drawn up. Where that is not the case, the document will be considered simply as any other written document or statement (judgment of 28/03/2012, T-214/08, 'Outburst', para. 32 and the case-law cited therein).

The evidential value of an affidavit is relative (judgment of 28/03/2012, T-214/08, 'OUTBURST', para. 33). In assessing the evidential value of such a document, the Office will consider first and foremost the credibility of the account it contains. It will then take account, in particular, of the person who produced the document, the circumstances in which it came about, the person to whom it was addressed and whether, on the face of it, the document appears sound and reliable (judgment of 07/06/2005, T-303/03, 'Salvita' para. 42 and the case-law cited therein). Affidavits containing detailed and concrete information and/or that are supported by other evidence have a higher probative value than very general and abstractly drafted statements.

The mere fact that affidavits from third parties are made according to a predetermined draft provided by the interested party (parties) does not in itself affect their reliability and credibility, and does not call into question their probative value since the veracity of their contents is certified by the signatory (judgment of 16/09/2013, T-200/10, 'Avery Dennison', para. 73).

4.3.3 Inspections

Only in very exceptional circumstances will the Office carry out an inspection *in situ*. If it does decide to carry out an inspection, it will, as with any other Office decision, state the means by which it intends to obtain evidence (in the present case, an inspection), the facts it wishes to prove, the date, and the time and place of the inspection.

The date fixed for the inspection must allow the party concerned sufficient time to prepare for it. If the inspection cannot take place for any reason, the proceedings will continue based on the evidence on file.

4.4 Costs of taking evidence

The Office may make the taking of evidence conditional upon a deposit by the party requesting it. The amount will be fixed by the Office based on an estimate of the costs.

The witnesses and experts summoned or heard by the Office will be entitled to reimbursement of expenses for travel and subsistence, including an advance. They will also be entitled to compensation for loss of earnings and payment for their work.

The amounts reimbursed and the advances for expenses are determined by the President of the Office and are published in the Office's Official Journal. For details, see Decision No EX-99-1 as amended by Decision No EX-03-2 of 20/1/2003.

Where the Office decides to adopt means of taking evidence that require oral evidence from witnesses or experts, the Office will bear the cost of this. However, where one of the parties has requested oral evidence, then that party will bear the cost, subject to a decision on the apportionment of costs in *inter partes* proceedings.

5 Oral Proceedings

Articles 77 and 78 CTMR Rules 56-60
--

Article 77 CTMR provides that the Office may hold oral proceedings.

Any unofficial contacts such as telephone conversations will not be considered to constitute oral proceedings within the meaning of Article 77 CTMR.

The Office will hold oral proceedings either on its own initiative or at the request of any party to the proceedings only when it considers these to be absolutely necessary. This will be at the Office's discretion (judgment of 20/02/2013, T-378/11, 'Medinet', para. 72 and the case-law cited therein). In the vast majority of cases it will be sufficient for the parties to present their observations in writing.

5.1 Opening of oral proceedings

Where the Office has decided to hold oral proceedings and to summon the parties, the period of notice may not be less than one month unless the parties agree to a shorter period.

Since the purpose of any oral proceedings is to clarify all outstanding points before the final decision is taken, the Office, in its summons, should draw the parties' attention to the points that need to be discussed in order for the decision to be taken.

Where the Office considers it necessary to hear oral evidence from the parties, witnesses or experts, it will take a decision stating the means by which it intends to obtain evidence, the relevant facts to be proven and the date, time and place of the hearing. The period of notice will be at least one month, unless the parties concerned agree to a shorter period. The summons will provide a summary of this decision and state the names of the parties to the proceedings and details of the costs, if any, that the witnesses or experts may be entitled to have reimbursed by the Office.

If required, and in order to facilitate the hearing, the Office may invite the parties to submit written observations or to submit evidence prior to the oral hearing. The period fixed by the Office for receiving these observations must allow sufficient time for them to reach the Office and then be forwarded to the other parties.

The parties may likewise submit evidence in support of their arguments on their own initiative. However, if this evidence ought to have been produced at an earlier stage of the proceedings, the Office will decide whether these items of evidence are admissible, taking account of the principle of hearing both parties, where appropriate.

5.2 Course of the oral proceedings

Oral proceedings before the examiners, the Opposition Division and the department entrusted with maintaining the Register will not be public.

Oral proceedings, including the delivery of the decision, will be public before the Cancellation Division and the Boards of Appeal, in so far as the department before which the proceedings are taking place does not decide otherwise in cases where admission of the public could have serious and unjustified disadvantages, in particular for a party to the proceedings.

If a party who has been duly summoned to oral proceedings does not appear before the Office, the proceedings may continue without them.

If the Office invites a party to give evidence orally, it will advise the other parties accordingly so that they can attend.

Similarly, when the Office summons an expert or a witness to a hearing, it will advise the parties concerned. These may be present and put questions to the person giving evidence.

At the end of the oral proceedings the Office should allow the parties to present their final pleadings.

5.3 Minutes of evidence and of oral proceedings

Rule 60 CTMIR

Minutes of the taking of evidence and of oral proceedings will be confined to the essential elements. In particular, they will not contain the verbatim statements made, nor will they be submitted for approval. However, any statements by experts or witnesses will be recorded so that at further instances the exact statements made can be verified. The parties will receive a copy of the minutes (but not of the recorded statements).

6 Decisions

6.1 Contents

Article 75 CTMR
Rule 55 CTMIR

Office decisions shall be reasoned to such an extent that their legality can be assessed at the appeal stage or before the General Court or Court of Justice.

The decision will cover the relevant points raised by the parties. In particular, if there are different outcomes for some goods and services of the CTM application or registration concerned, the decision will make clear which of the goods and services are refused and which are not.

The name or names of the person(s) who took the decision will appear at the end of the decision (Rule 55 CTMIR)

At the end of the decision, there will also be a notice advising of the right to appeal.

Failure to include this notice does not affect the legality of the decision and does not affect the deadline for filing an appeal.

6.2 Apportionment of costs

Article 82(5) and Article 85 CTMR
Rules 51 and 94 CTMIR

In *ex parte* proceedings, there is no decision on costs, nor any apportionment of costs. The Office will not reimburse any fees paid (the exceptions are Rule 51 CTMIR, refund of the appeal fee in certain cases, and Article 82(5) CTMR, refund of the fee for further processing if further processing is not granted).

Decisions on costs, or the fixing of costs, are limited to opposition and cancellation proceedings (including the ensuing appeal proceedings or proceedings before the GC and CJEU). 'Costs' comprise the costs incurred by the parties to the proceedings, chiefly (i) representation costs (although the thresholds are relatively low) and costs for taking part in oral hearings; 'representation costs' means the costs for professional

representatives within the meaning of Article 93 CTMR, not for employees (even from another company with economic links); (ii) the opposition or cancellation fee paid by the opponent or third party.

‘Apportionment of costs’ means that the Office will decide whether and to what extent the parties have to reimburse each other. It does not involve the relationship with the Office (fees paid, the Office’s internal costs).

Therefore, if a decision is given in *inter partes* proceedings, the Office will decide on the apportionment of costs. The losing party will bear the fees and costs incurred by the other party that are essential to the proceedings. If both parties fail on one or more heads or if reasons of equity so dictate, the Office may determine a different apportionment of costs.

The decision will fix the costs to be paid by the losing party/parties. No proof that these costs were actually incurred is needed for this purpose.

This part of the decision is a title that can be executed in simplified proceedings, in all Member States of the EU.

If the contested CTM application or CTM is withdrawn or surrendered, or the opposition or request for cancellation is withdrawn, the Office will not decide on the substance of the case, although it will normally take a decision on costs. The party terminating the proceedings will bear the fees and costs incurred by the other party. Where the case is closed for other reasons, the Office will fix the costs at its discretion. In no case will the decision on costs be based on hypothetical assumptions about who might have won the proceedings if a decision on substance had been taken. Furthermore, within one month of the date of notification fixing the amount of the costs, the party concerned may request a review. This request must state the reasons on which it is based and must be accompanied by the corresponding fee (Article 2(30) CTMFR).

***GUIDELINES FOR EXAMINATION IN THE
OFFICE FOR HARMONIZATION IN THE
INTERNAL MARKET (TRADE MARKS AND
DESIGNS) ON COMMUNITY TRADE MARKS***

PART A

GENERAL RULES

SECTION 4

LANGUAGE OF PROCEEDINGS

Table of Contents

1	Introduction	3
2	From filing to registration (excluding opposition)	3
2.1	Application	3
2.2	Other requests	4
3	After registration (excluding cancellation)	4
4	Opposition and cancellation.....	4
5	Invariable nature of the language rules	5
6	Translations and their certification	5
7	Non-compliance with the language regime	5

1 Introduction

Article 119 CTMR Rules 95, 96, 98 CTMIR Communication No 4/04 of the President of the Office
--

There are five Office languages: English, French, German, Italian and Spanish. However, an application for a Community trade mark may be filed in any of the official EU languages. The CTMR lays down rules for determining and using the language of the proceedings. These rules may vary from one set of proceedings to another, in particular depending on whether the proceedings are *ex parte* or *inter partes*.

This section deals only with the horizontal provisions common to all types of proceedings. The exceptions for particular types of proceedings are dealt with in the corresponding sections of the Guidelines.

2 From filing to registration (excluding opposition)

2.1 Application

A Community trade mark application (CTM application) may be filed in any of the official EU languages.

A second language must be indicated from among the five languages of the Office.

During the proceedings, the applicant may use

- the first language if it is an Office language;
- or the second language, at its discretion, if the first language is not an Office language.

The Office uses

- only the first language if it is an Office language;
- the first language if it is not an Office language, following the CJEU 'Kik' judgment (judgment of 09/09/2003, C-361/01 P), unless the applicant has declared in writing its consent for the Office to use the second language, in which case the Office proceeds accordingly. Consent to use of the second language must be given for each individual file; it may not be given for all existing or future files.

This language regime applies throughout the application and examination procedure until registration, except for oppositions and ancillary requests (see following paragraph).

2.2 Other requests

Rule 95(a) CTMIR

During the period from filing to registration, any request, application or declaration that is not concerned with the examination of the application as such but that starts an ancillary procedure (inspection of files, registration of a transfer or licence, request for conversion, declaration of division) may be submitted in the first or second language, at the discretion of the CTM applicant or third party. That language then becomes the language of the proceedings for those ancillary proceedings. This applies irrespective of whether or not the first language is an Office language.

3 After registration (excluding cancellation)

Rule 95(b) CTMIR

Any request, application or declaration of division or surrender, with the exception of a cancellation request, made after the CTM has been registered must be submitted in one of the five Office languages.

Example: After a CTM has been registered, the CTM proprietor may file a request for the registration of a licence in English and, a few weeks later, file a request for renewal in Italian.

4 Opposition and cancellation

Rules 16 and 38(1) CTMIR

An opposition or request for cancellation (application for revocation or declaration of invalidity) may be filed

- at the discretion of the opponent/applicant for cancellation in the first or second language of the CTM application if the first language is one of the five languages of the Office;
- in the second language if the first language is not an Office language.

This language becomes the language of the proceedings for the opposition or cancellation proceedings, unless the parties agree to a different one (from among the official EU languages).

An opposition or request for cancellation may also be filed in any of the other Office languages, provided that within one month of the expiry of the opposition period or within one month of the filing of the application for cancellation, the opponent/applicant for cancellation files a translation into a language that is available as a language of proceedings.

5 Invariable nature of the language rules

The Regulations allow certain choices to be made from among the available languages in the course of the proceedings (see above) and, during specified periods, a different language to be chosen as the language of the proceedings for opposition and cancellation. However, with those exceptions, the language rules are invariable. In particular, the first and second languages may not be amended in the course of the proceedings.

6 Translations and their certification

Rule 98 CTMIR

The general rule is that where a translation of a document is required, it must reach the Office within the time limit set for filing the original document. This applies unless an exception to this rule is expressly provided in the Regulations.

The translation must identify the document to which it refers and reproduce the structure and contents of the original document. The Office may require that a certified translation be filed within a specific period, but does so only if it has reason to doubt the veracity of the translation.

7 Non-compliance with the language regime

In case the language regime is not complied with the Office will issue a deficiency letter. Should the deficiency not be remedied the application or the request will be refused.

For more information on language regimes for particular types of proceedings the corresponding sections of the Guidelines should be consulted.

***GUIDELINES FOR EXAMINATION IN THE
OFFICE FOR HARMONIZATION IN THE
INTERNAL MARKET (TRADE MARKS AND
DESIGNS) ON COMMUNITY TRADE MARKS***

PART A

GENERAL RULES

SECTION 6

***REVOCATION OF DECISIONS,
CANCELLATION OF ENTRIES IN THE
REGISTER AND CORRECTION OF ERRORS***

Table of Contents

1	Revocation of Decisions and Cancellation of Entries in the Register ..	3
1.1	Obvious procedural error attributable to the Office.....	3
1.2	Who decides on requests for revocation/cancellation?	4
1.3	Procedural aspects	4
1.3.1	Assessment	5
1.3.2	Distinction between one and two parties.....	5
1.3.2.1	Procedures for one party.....	6
1.3.2.2	Procedure for more than one party.....	6
2	Correction of Errors in Decisions and other Notifications	7
2.1	Correction of errors in decisions	7
2.1.1	General remarks	7
2.1.2	Procedural aspects	8
2.1.2.1	Time limit	8
2.1.2.2	Assessment.....	8
2.1.2.3	Procedure.....	8
2.2	Correction of errors in notifications other than decisions	9
3	Correction of Errors in Publications and Correction of Errors in the Register or in the Publication of the Registration	9

1 Revocation of Decisions and Cancellation of Entries in the Register

Article 80 CTMR

Under certain conditions a decision taken by the Office can be revoked or an entry in the Register cancelled. This part of the Guidelines deals with the practical aspects of revocation/cancellation under Article 80 CTMR; it does not apply to Registered Community designs (RCDs).

The revocation procedure can be initiated either by a party to the proceedings or by the Office on its own motion.

A decision can only be revoked by another decision. The same applies to cancellations of entries in the register.

1.1 Obvious procedural error attributable to the Office

A decision may be revoked or an entry in the Register cancelled only when it contains an obvious procedural error attributable to the Office.

A decision/entry contains an obvious procedural error where there was an error in the proceedings (usually when an essential procedural step was omitted) or where the decision/entry ignores a procedural action taken by the parties. Procedural errors have to be distinguished from errors in substance, where no revocation is possible. The decision/entry is wrong from a procedural point of view (i.e. suffers from an obvious procedural error) if the procedure established by the Regulations was not followed properly.

The following is a non-exhaustive list of examples of obvious procedural errors demanding revocation.

- The CTM is registered despite having previously been withdrawn.
- The opposition has been found admissible even though some admissibility requirements were not met (see CJEU judgment of 18/10/2012, C-402/11 P, 'REDTUBE').
- The CTM is registered despite a deficiency in the payment of the application fees.
- The CTM is registered despite a successful opposition.
- The CTM's refusal on absolute grounds is notified before expiry of the time limit given to the applicant to send observations in reply to the objection, or ignoring the observations the applicant filed on time. (Where the applicant has responded within the time limit, the examiner can continue dealing with the application, for example by issuing a decision, and is not required to wait until expiry of the time limit set in the objection letter.)

- The CTM is refused on absolute grounds, ignoring a valid request from the applicant for the opportunity to submit evidence of acquired distinctiveness (Article 7(3) CTMR).
- The CTM is refused on absolute grounds, ignoring the evidence of acquired distinctiveness duly submitted.
- The CTM is refused by the Opposition Division, ignoring an unprocessed request for proof of use or without dealing with the issue of proof of use.
- The CTM is registered despite a pending opposition.
- The opposition is rejected on the basis of lack of proof of use but
 - the opponent was not expressly given a time limit for submitting proof of use;
 - proof of use was filed on time and was overlooked.
- The opposition decision was rendered while the proceedings were suspended or interrupted or, more generally, while a time limit for one of the parties was still running.
- Any breach of the right to be heard (observations not forwarded to the other party when that party should have been given a time limit to reply pursuant to the Regulation or the Office's practice).
- When closing a file due to a limitation of the contested CTMA or a withdrawal, the Office has issued a decision on costs, overlooking an agreement between both parties on costs that was on file at the time.
- A transfer of ownership was entered in the Register despite insufficient evidence of the transfer.

Whether or not these procedural errors were a result of human error or of the incorrect functioning of an IT tool is immaterial.

The *effect* of the revocation of a decision or of the cancellation of an entry in the Register is that the decision or entry is deemed to never have existed. The file is returned to the procedural stage it was at before the erroneous decision or entry was made.

1.2 Who decides on requests for revocation/cancellation?

Decisions on revocation/cancellation are made by the department or unit who made the entry or took the decision and can be appealed under Article 58(2) CTMR.

1.3 Procedural aspects

Article 80 CTMR

1.3.1 Assessment

Examiners must verify, firstly, whether the decision or entry contains an obvious procedural error, secondly, whether more than six months have passed since notification of the decision or entry in the Register and, thirdly, whether there has been an appeal against the decision/entry in the Register.

- (a) **Assessment:** It must be verified whether the decision or entry contains an obvious procedural error. For further information see above under paragraph 1.1.
- (b) **Six months:** Whenever an obvious procedural error comes to the attention of an examiner, it must be established whether more than six months have passed since notification of the decision or entry in the Register. Revocation/cancellation is not possible if more than six months have passed (Article 80(2) CTMR).

Article 80 CTMR mentions that cancellation or revocation 'shall be determined' within six months of the date of the entry or decision. This means that even if the time limit has lapsed, an entry will be cancelled or a decision revoked if the Office is made aware in writing of an obvious procedural error in that entry or decision within six months of notification of that entry/decision. It also means that an entry can be cancelled or a decision revoked after the six-month period if the Office sends a notification initiating the cancellation/revocation proceedings within six months of notification of that entry/decision.

- (c) **Decision/entry against which appeal pending:** Before issuing a letter notifying parties of its intention to cancel an entry or revoke a decision, and before actual cancellation/revocation, the Office must verify whether the decision or entry in the Register has been appealed against. **A decision or entry cannot be revoked/cancelled if an appeal against it is pending before the Boards** (decision of 28/04/2009, R 323/2008-G – 'BEHAVIOURAL INDEXING').

1.3.2 Distinction between one and two parties

The procedure where only **one party** is affected is described below in paragraph 1.3.2.1. Examples are when the Office duly receives third-party observations that raise doubts but the CTMA is not blocked and continues to registration, and where a CTMA is registered although the application fee has not been paid.

Errors that concern incorrect handling of the files after a decision has been taken, for example where a CTMA is registered despite having been refused on absolute grounds, affect only one party – the applicant.

If revocation of a decision is likely to affect **more than one party**, the procedure described below in paragraph 1.3.2.2 must be followed. For example, more than one party is affected by the revocation of a decision in opposition proceedings where the Office overlooked a request for proof of use.

Errors that concern incorrect handling of the files after an opposition decision has been taken, such as where the entire CTMA is rejected but is still registered, are considered to affect both the applicant and the opponent.

Errors in registering a transfer of ownership also affect more than one party. While the procedure is essentially *ex parte*, the Office may, depending on the case, consider that

more than one party is affected: the new owner, the old owner and the third party that should have been entered in the Register.

1.3.2.1 Procedures for one party

Error found by Office

If the Office itself finds out that an error has been made, it informs the applicant/owner of its intention to revoke the decision/cancel the entry and sets a time limit for observations of one month if the applicant/owner has its head office in the EU or two months if it does not. The letter must state the reasons for the revocation/cancellation.

If the applicant/owner agrees or does not submit any observations, the Office revokes the decision/cancels the entry.

If the applicant/owner does not agree to revocation or cancellation, a formal decision has to be taken, which is subject to the usual requirements as described in the Guidelines, Part A, General Rules, Section 2, General Principles to be respected in Proceedings, paragraph 7, Decisions.

Error notified by affected party

If the applicant/owner informs the Office in writing of an error that will be understood as a request for revocation/cancellation, there is no need to ask for observations. In such cases, it must be determined whether the request for revocation/cancellation is eligible. If so, the decision or entry in the Register is revoked/cancelled. If the Office finds that there are no reasons to revoke/cancel, it rejects the party's request by a decision, giving the reasons why the request is rejected.

1.3.2.2 Procedure for more than one party

Error found by Office

If the Office itself finds out that an error has been made, it informs both parties of its intention to revoke the decision/cancel the entry and sets a time limit for observations of, in principle, two months (reduced to one month if both parties have their respective head offices in the EU).

If the parties agree or do not submit any observations in reply, the Office must revoke/cancel the decision/entry in the Register.

If one of the parties does not agree to the revocation/cancellation, a reasoned decision has to be taken, which is subject to the usual requirements as described in the Guidelines, Part A, General Rules, Section 2, General Principles to be respected in Proceedings, paragraph 7, Decisions.

Error notified by one of the parties

If the party adversely affected by the error informs the Office in writing of an error that will be understood as a request for revocation/cancellation, it must be determined

whether the request for revocation/cancellation is eligible. If so, the Office notifies the party that benefited from the error (the other party) of its intention to revoke/cancel (and sends a copy of this notification to the first party for information). A time limit for observations of, in principle, two months is set (which may be reduced to one month if the adversely affected party has its head office in the EU).

If the other party agrees or does not submit any observations in reply, the Office must revoke the decision/cancel the entry.

If the other party does not agree to revocation or cancellation, a reasoned decision has to be taken, which is subject to the usual requirements as described in the Guidelines, Part A, General Rules, Section 2, General Principles to be respected in Proceedings, paragraph 7, Decisions.

For example, where an opponent that has seen its opposition upheld and the CTMA rejected informs the Office that the CTMA has nevertheless been registered, the applicant must be informed and given two months to submit observations. The entry will be cancelled regardless of whether the applicant agrees or does not reply.

If the party that benefited from the error informs the Office in writing, it must be determined whether the request for revocation/cancellation is eligible. If so, the party adversely affected by the error must be informed accordingly. As revocation/cancellation will be to the latter's advantage, the decision can be revoked or entry cancelled at the same time as the letter is sent (to both parties). There is no need for the party that benefited from the error to submit observations, as its letter informing the Office of the error can be taken as its agreement to revocation/cancellation.

For example, where an applicant informs the Office that its CTMA has been registered despite being rejected by decision of the Office, the entry in the Register must be cancelled. There is no need to hear the opponent.

Finally, once a revocation or cancellation has become final, it must be published if a wrong entry in the Register has already been published. If the Office finds that there are no reasons to revoke a decision/cancel an entry, it will reject the relevant request by letter and send copies of both this letter and the original request to the other party for information.

2 Correction of Errors in Decisions and other Notifications

Rule 53 CTMIR

2.1 Correction of errors in decisions

2.1.1 General remarks

According to Rule 53 CTMIR, where the Office becomes aware, of its own motion or at the instance of a party to the proceedings, of a linguistic error, error of transcription or obvious mistake in a decision, it has to ensure that the error or mistake is corrected by the department or division responsible. It is apparent from the wording that the only legitimate purpose of corrections made on the basis of this provision is to correct spelling or grammatical errors, errors of transcription – such as errors relating to the names of the parties or the written forms of the signs – or errors that are so obvious

that nothing other than the wording as corrected could have been understood. However, when the error affects the dictum of a decision, only revocation is possible, and then only if all the conditions are met.

The Office defines 'obvious error' as in No B.16 in the Joint Statements by the Council and the Commission entered in the minutes of the Council meeting at which the CTMR was adopted in relation to Article 44(2) CTMR and to Rule 53 CTMR: '... the words "obvious mistake" should be understood as meaning mistakes which obviously require correction, in the sense that nothing else would have been intended than what is offered as the correction.'

The distinction between revocation under Article 80 CTMR and correction under Rule 53 CTMR is that revocation annuls a decision, whereas the correction of errors does not affect the validity of the decision and does not open a new appeal period.

An example of an error of transcription would be when a trade mark is referred to incorrectly, for example, 'HAMMER' is referred to as 'HUMMER'.

An example of an obvious error is when the earlier mark and the contested mark are interchanged in the comparison of the signs.

2.1.2 Procedural aspects

2.1.2.1 Time limit

The Regulations do not set a time limit for the correction of errors in decisions. This suggests that corrections can be made any time, as long as they do not clash with the principle of equity.

2.1.2.2 Assessment

Examiners must verify, firstly, whether the error to be corrected is a linguistic error, an error of transcription or an obvious error and, secondly, whether there has been an appeal against the decision.

- (a) **Assessment:** Before sending a correction letter, the examiner must verify whether the error to be corrected is a linguistic error, an error of transcription or an obvious error.
- (b) **Appeal:** The examiner must also verify whether there has been an appeal against the decision. **No correction can be made if an appeal against the decision is pending before the Boards.** However, the Boards must be informed of the situation.

2.1.2.3 Procedure

Linguistic errors, errors of transcription and obvious errors are corrected by sending a corrigendum to the affected party/parties. The accompanying letter must briefly explain the corrections.

Once the correction has been made, the examiner makes sure that the changes are reflected in the decision as it appears in the Office's database.

The date of the decision or entry **remains unchanged after correction. Therefore, the time limit for appeal is not affected.**

When the fixation of costs is part of the dictum of the decision it can be corrected only by revocation.

2.2 Correction of errors in notifications other than decisions

Errors in notifications other than decisions can be remedied by sending a corrected notification indicating that the latter replaces and annuls the one previously sent. The notification should include an apology for any inconvenience caused.

3 Correction of Errors in Publications and Correction of Errors in the Register or in the Publication of the Registration

Article 39 CTMR Rules 14, 27, 84, 85 CTMIR

Article 39 CTMR states that CTMAs that have not been refused on absolute grounds should be published one month after the search report has been issued.

Rule 14 CTMIR refers to the correction of mistakes and errors in the publication of the application pursuant to Article 39 CTMR.

Rule 27 CTMIR refers to mistakes and errors in the registration of a CTM or in any entry made in the Register in accordance with Rule 84 CTMIR, including any Decision of the President pursuant to Rule 84(4) CTMIR, and to errors in the publication of the those entries in the Register.

The main difference between the correction of an entry in the Register pursuant to Rule 27 and the cancellation of an entry in the Register pursuant to Article 80 CTMR is that the former relates to only one part of the publication, whereas the latter cancels the whole entry in the Register.

Where there is an error attributable to the Office, the latter corrects it either of its own motion (where the Office itself has become aware of the error) or at the proprietor's request.

Corrections of errors in CTM applications that do not require republication of the application for opposition purposes are published in Section B.2 of the Bulletin. Corrections pursuant to Rule 14 CTMIR that do require republication of the application for opposition purposes are published in Section A.2. However, republication will only be required if the initial publication published a more limited list of goods and services.

In all cases, the affected party/parties are notified of the corrections pursuant to Rule 14 or 27.

The following are examples of errors that can be corrected (Rule 27(1) CTMIR).

- The CTM has been published for one class fewer than applied for.
- The sign 'x' was applied for and the publication refers to the sign 'y', or the list of goods and services published is wrong.
- The CTM has been registered without taking into consideration a limitation.

Corrections of errors in registered CTMs that do not require republication for opposition purposes are published in subsection B.4.2 of the Bulletin. Corrections pursuant to Rule 27 CTMIR that require republication of part of the application for opposition purposes are published in subsection A.2.1.2.

Republication for opposition purposes will always be required where a correction involves changes to the representation of the mark or a broadening of the list of goods and services already published. For other corrections, republication must be decided on a case-to-case basis.

Corrections to entries in the Register must be published pursuant to Rules 27(3) and 85(2) CTMIR. Corrections of relative errors in an entry in the Register are published in subsection B.4.2 of the Bulletin. All the examples listed above (of corrections and of revocation/cancellations) require publication.

No correction need be published pursuant to Rule 27 CTMIR when the initial publication was in the wrong section of the Bulletin. According to Communication No 11/98 of the President of the Office of 15/12/1998, 'the legal effect of the publication under Article 9(3) of the Community Trade Mark Regulation remains the same regardless of whether the publication is made in Part B. 1 or Part B. 2 of the Bulletin'.

Time limit: There is no time limit for corrections pursuant to Rule 14 or Rule 27 CTMIR. They can be made at any time once the error has been detected.

***GUIDELINES FOR EXAMINATION IN THE
OFFICE FOR HARMONIZATION IN THE
INTERNAL MARKET (TRADE MARKS AND
DESIGNS) ON COMMUNITY TRADE MARKS***

PART A

GENERAL RULES

SECTION 7

REVISION

Table of Contents

1	General Principles	3
1.1	Introduction	3
1.2	In <i>ex parte</i> cases	3
1.3	In <i>inter partes</i> cases	3
2	Procedure where Revision is Available	4
2.1	Verification of whether the appeal is deemed to have been filed	4
2.2	Verification whether the appeal is admissible.....	4
2.3	Verification whether the appeal is well founded	5
2.3.1	Situations where the initial decision may be rectified	5
2.3.2	Situations where, although the appeal is well founded, revision may not be granted.....	5
2.4	Impact of a request for <i>restitutio in integrum</i>	5
2.5	Decision to grant revision.....	6
2.5.1	Deadline for taking the decision	6
2.5.2	Contents of the decision	6
2.6	Appeal against the decision	6
2.7	Communication of the decision	7
3	Procedure where Revision is not Granted	7

1 General Principles

Articles 61, 62 CTMR

1.1 Introduction

It is the responsibility of the Boards of Appeal to decide on an appealed decision. Pursuant to Articles 61 and 62 CTMR, the Board sends the appealed decision back to the department that took the decision in order for it to be revised. This enables the first-instance decision-taker to rectify the decision if the appeal is admissible and well founded. *Inter partes* cases may only be rectified if authorised by the other party (see decision of 11/08/2009, R 1199/2008-4 – ‘DIPLOMÁTICO/DIPLOMAT’)

The purpose of revision is to avoid the Boards of Appeal being inundated with appeals against decisions for which a need for rectification has been recognised by the Office. However, the aim is not to remove mistakes in decisions made by the Office without changing the outcome of a case, but to grant the appellant the relief sought.

1.2 In *ex parte* cases

Revision can be granted where an appeal has been lodged against a decision for which the Boards of Appeal are competent pursuant to Article 58 CTMR.

If the division or instance of the Office whose decision is appealed considers the appeal to be admissible and well founded, it must rectify its decision.

If the decision is not rectified within one month after receipt of the statement of grounds of appeal, the appeal must be remitted to the Boards of Appeal without delay and without comment as to its merits.

1.3 In *inter partes* cases

Revision is also available in *inter partes* proceedings. These comprise opposition proceedings (including where the opposition is rejected as inadmissible), proceedings concerning applications for revocation or declaration of invalidity, and certain proceedings concerning inspection of files.

Revision is not available where the one-month time limit following receipt by the Office of the statement of grounds of appeal has expired.

Revision requires a pending appeal. It is not available where an appeal has been withdrawn before the one-month time limit for revision has expired and a decision on revision has not yet been taken.

2 Procedure where Revision is Available

Articles 61, 130 CTMR

Where revision is available, the Registrar of the Board of Appeal sends the appeal documents and any subsequent communications relating to the appeal to the Office division that took the decision.

The division concerned examines whether revision may be granted.

Revision may only be granted where the appeal is admissible and well founded.

2.1 Verification whether the appeal is deemed to have been filed

Article 60 CTMR
Rule 49(3) CTMIR
Article 2(18), Article 8(3), (4) CTMFR

As an appeal is deemed to have been filed only when the appeal fee has been paid, the appealed decision for which the appeal fee has not been paid may not be revised.

The competent division must, therefore, verify whether the appeal fee has been fully paid within two months of notification of the contested decision.

Otherwise, the appealed decision cannot be revised and has to be remitted without delay (not necessarily only at the end of the one-month time limit) to the Registrar at the Boards of Appeal.

For more details on fees, see the Guidelines, Part A, General Rules, Section 3, Payment of Fees, Costs and Charges.

2.2 Verification whether the appeal is admissible

Articles 58-60 CTMR
Rule 48, Rule 49(1), (2) CTMIR

The competent division must be satisfied that the appeal is admissible, that is that it complies with the requirements laid down in Articles 58 to 60 CTMR and Rule 48(1)(c) and Rule 48(2) CTMIR, as well as with all other requirements to which Rule 49(2) CTMIR refers.

The competent division may not under any circumstances contact the appellant to remedy formal or substantive deficiencies of the appeal. This prohibition includes oral contact. Where the requirements for admissibility of the appeal are not met, the case must be remitted without delay to the Boards of Appeal.

Where the language used is not available for lodging the appeal, revision will not be granted.

Where essential indications such as the applicant's name and address are missing or there is no signature or authorisation, revision will not be granted.

2.3 Verification whether the appeal is well founded

The competent division has to verify whether the appeal is well founded.

2.3.1 Situations where the initial decision may be rectified

The relevant date for assessing whether the appeal is well founded is that on which the competent division examines whether or not revision can be granted.

The appeal is well founded where the contested decision was incorrect.

2.3.2 Situations where, although the appeal is well founded, revision may not be granted

Articles 7(3), 37(1) CTMR Rules 9, 11 and 13 CTMIR

Revision may be granted only if the objections raised by the Office are completely overcome.

For example, an appeal may not be revised where the CTM applicant only partially removes the deficiencies pointed out by the Office.

Another example is where the examiner has objected to the list of goods and services and the CTM applicant files a new list of goods and services that fails to completely overcome the examiner's objections and requires further examination.

A further example is when the Office has rejected a CTM application on absolute grounds but in its appeal the CTM applicant argues that the mark has acquired distinctiveness through use, which then requires proof.

Revision is not available when granting it would merely re-open but not resolve the issue. Revision need not necessarily result in a positive decision on the main issue (for example, in the case of a CTM application, in registration or at least publication): it may grant relief to the appellant insofar as it seeks to reverse a decision. When determining whether revision would grant the requested relief, the contested decision and the reasons on which it is based are taken as the basis.

2.4 Impact of a request for *restitutio in integrum*

Articles 60, 81 CTMR

Revision may not be granted where a notice of appeal, or a written statement of the grounds of appeal, was not filed in time but is accompanied by a request for *restitutio in integrum* seeking restoration of the two-month time limit for lodging an appeal or filing

the statement of grounds. The appeal will be remitted to the Boards of Appeal without delay.

2.5 Decision to grant revision

Article 61(2) CTMR Rules 51 and 52 CTMIR

If the competent division concludes that revision should be granted, it must take a decision to this effect within one month of receipt of the statement of grounds of appeal.

2.5.1 Deadline for taking the decision

The decision must be dispatched at the latest on the last day of the time limit. It does not matter whether the date of notification of the decision is after that date. If, for example, the decision is notified by registered mail, the registered letter must be posted at the latest on the last day of the time limit.

2.5.2 Contents of the decision

The contents of the decision must at least provide for the annulment of the initial decision and may provide for further treatment of the case – for example, that the CTM application be registered or the registration of transfer applied for be entered in the files of the CTM application.

The decision must also state whether or not the appeal fee is reimbursed.

Reimbursement of the appeal fee is ordered only if equitable by reason of a substantial procedural violation. The basic consideration is whether or not the Office was at fault on the date on which the contested decision was taken. If the contested decision is found to be incorrect in itself, reimbursement is granted. If the contested decision was correct on the date on which it was taken, no reimbursement is granted unless it is established that a document or observation removing the deficiency raised by the Office was actually received by the Office prior to the decision but not included in the file in time.

Where the appeal fee has been paid through a current account, the current account holder is reimbursed through that same account. Where it has not yet been debited, the decision will state that no appeal fee will be debited.

2.6 Appeal against the decision

Article 58 CTMR

Decisions to grant revision cannot be appealed.

A decision not to reimburse the appeal fee may be appealed separately.

2.7 Communication of the decision

Once revision is granted, the competent division informs the Registrar of the Boards of Appeal accordingly.

3 Procedure where Revision is not Granted

Article 61(2) CTMR

When the competent division concludes that the conditions for granting revision are not met, and at the latest upon expiry of the one-month time limit provided for in Article 61(2) CTMR, the competent division must remit the case to the Boards of Appeal without any comment or statement.

When the competent division remits the case without comments, no decision has to be taken to refuse revision.

**GUIDELINES FOR EXAMINATION IN THE
OFFICE FOR HARMONIZATION IN THE
INTERNAL MARKET (TRADE MARKS AND
DESIGNS)**

PART A

GENERAL RULES

SECTION 8

RESTITUTIO IN INTEGRUM

Table of Contents

1	General Principles	3
2	Criteria for Granting <i>restitutio</i>	3
2.1	The condition of ‘all due care required by the circumstances’	3
2.2	Loss of rights or means of redress caused directly by failure to meet the time limit	5
3	Procedural aspects	5
3.1	Proceedings to which <i>restitutio</i> applies	5
3.2	Parties	6
3.3	Time limit for national offices to forward an application to the Office ...	6
3.4	Time limits excluded from <i>restitutio in integrum</i>	6
3.5	Effect of <i>restitutio in integrum</i>	7
3.6	Time limit	7
3.7	Fee.....	8
3.8	Languages	8
3.9	Particulars and Evidence.....	8
3.10	Competence.....	9
3.11	Publications.....	9
3.12	Decision, role of other parties in <i>restitutio</i> proceedings	9
4	Third-Party Proceedings	10

1 General Principles

Article 81 CTMR
Article 67 CDR

Parties to proceedings before the Office may have their rights reinstated (*restitutio in integrum*) if they were unable to meet a time limit vis-à-vis the Office, despite taking all due care as required by the circumstances, provided that the failure to meet the time limit had the direct consequence, by virtue of the provisions of the Regulations, of causing a loss of rights or loss of means of redress (judgment of 28/06/2012, T-314/10, 'Cook', paras 16 and 17).

Observing time-limits is a matter of public policy and granting *restitutio in integrum* can undermine legal certainty. Consequently, the conditions for the application of *restitutio in integrum* have to be interpreted strictly (judgment of 19/09/2012, T-267/11, 'VR', para. 35).

Restitutio in integrum is only available upon application to the Office and there is a charge for this.

If the party is represented, the representative's failure to take all due care is attributable to the party that it represents (judgment of 19/09/2012, T-267/11, 'VR', para. 40).

2 Criteria for Granting *restitutio*

There are two requirements for *restitutio in integrum* (judgment of 25/04/2012, T-326/11, 'BrainLAB', para. 36):

- a) that the party has exercised all due care required by the circumstances,
- b) and that the non-observance (of a deadl ine) by the party has the direct consequence of causing the loss of any right or means of redress.

2.1 The condition of 'all due care required by the circumstances'

Rights will be re-established only under exceptional circumstances that cannot be predicted from experience (judgment of 13/05/2009, T-136/08, 'Aurelia', para. 26) and which are therefore unforeseeable and involuntary.

a) Examples of where the 'all due care' requirement has been fulfilled

In principle, failure to deliver by the postal or delivery service does not involve any lack of due care by the party concerned (decision of 25/06/2012, R 1928/2011-4, 'Sun Park Holidays'). However, it is up to the parties' representatives at least to find out in advance from their delivery company what the usual delivery times are (in the case of letters sent from Germany to Spain in decision of 04/05/2011, R 2138/2010-1 – 'Yellowline').

The degree of due care that the parties must demonstrate in order to have their rights re-established must be determined in the light of all the relevant circumstances.

Relevant circumstances may include a relevant error made by the Office and its repercussions. Thus, even though the party concerned has failed to take all due care, a relevant error by the Office may result in the granting of *restitutio* (judgment of 25/04/2012, T-326/11, 'BrainLAB', para. 57 and para. 59).

Circumstances such as natural disasters and general strikes are regarded as fulfilling the requirement for all due care.

b) Examples of where the 'all due care' requirement has NOT been fulfilled

Errors in the management of files caused by the representative's employees or by the computerised system itself are foreseeable. Consequently, due care would require a system for monitoring and detecting any such errors (judgment of 13/05/2009, T-136/08, 'Aurelia', para. 18).

'The exceptional workload and organisational strains to which the applicants claim they were subject as a result of the entry into force of Regulation No 40/94 are irrelevant in that connection' (judgment of 20/06/2001, T-146/00, 'DAKOTA', para. 62.)

An erroneous calculation of the time limit does not constitute an exceptional event that cannot be predicted from experience (decision of 05/07/2013, R 0194/2011-4 – 'PayEngine').

An error by the Renewals Department Manager, who monitors staff performance daily, does not constitute an exceptional event (decision of 24/04/2013, R 1728/2012-3, - 'Part of lifting device').

The absence of a key member of the Accounts Department cannot be regarded as an exceptional or unforeseeable event (decision of 10/04/2013, R 2071/2012-5 – 'Starforce').

A clerical error in entering a deadline cannot be regarded as an exceptional or unforeseeable event (decision of 31/01/2013, R 0265/2012-1 – 'Kansi').

A misunderstanding of the applicable law may not, as a matter of principle, be regarded as an 'obstacle' to compliance with a time limit (decision of 14/06/2012, R 2235/2011-1 – 'KA').

Delay by the owner in providing instructions is not an exceptional event (decision of 15/04/2011, R 1439/2010-4 – 'Substral Nutri + Max').

Financial problems at the proprietor's business, its closure and the loss of jobs cannot be accepted as a reason for the proprietor not to be able to observe the time-limit to renew its Community trade mark (decision of 31/03/2013, R 1397/2010-1 – 'Captain').

Legal errors by a professional representative do not warrant *restitutio* (decision of 16/11/2010, R 1498/2010-4 – 'Regine's'). The deletion of a deadline by an assistant is not unforeseeable (decision of 28/06/2010, R 0268/2010-2 – 'Orion').

2.2 Loss of rights or means of redress caused directly by failure to meet the time limit

Article 81(1) CTMR

Failure to meet the time limit must have had the direct consequence of causing the loss of rights or means of redress (judgment of 15/09/2011, T-271/09, 'Romuald Prinz Sobieski zu Schwarzenberg', para. 53).

Articles 42(2), 76(2) and 77(1) CTMR
Rule 19, and Rules 20(1)-(5) and 40(1)-(3) CTMIR

This is not the case where the Regulations offer procedural options that parties to proceedings are free to use, such as requesting an oral hearing, requesting that the opponent prove genuine use of its earlier mark, or applying for an extension of the cooling-off period, pursuant to Rule 19 CTMIR. The cooling-off period itself is not subject to *restitutio* either because it is not a time limit by which a party must perform an action.

Article 36(1), (4), and Article 37 CTMR
Rule 9(3), (4), Rule 10 and Rule 11(1) (3) CTMIR

On the other hand, *restitutio in integrum* does apply to the late response to an examiner's notification of refusal if the application is not rectified by the time limit specified because in this case there is a direct relationship between failure to meet the time limit and possible refusal.

Restitutio is also available for the late submission of facts and arguments and late filing of observations on the other party's statements in *inter partes* proceedings if and when the Office refuses to take them into account as being filed too late. The loss of rights in this case involves the exclusion of these submissions and observations from the facts and arguments on which the Office bases its decision. (In principle, the Office will disregard any statements filed in *inter partes* proceedings after the deadline has passed.)

3 Procedural aspects

Article 81(2) CTMR
Rule 83(1)(h) CTMIR
Article 67(2) CDR
Article 68(1)(g) CDIR

3.1 Proceedings to which *restitutio* applies

Restitutio is available in all proceedings before the Office.

This includes proceedings under the CTMR and proceedings concerning registered Community designs under the CDR. The respective provisions do not differ materially.

Restitutio is available in *ex parte* proceedings, *inter partes* proceedings and appeal proceedings.

For *restitutio* in relation to the missed time limit for lodging an appeal and in relation to revision, see the Guidelines, Part A, General Rules, Section 7, Revision.

3.2 Parties

Article 81 CTMR Article 67 CDR

Restitutio is available to any party to proceedings before the Office - not only to the applicant for, or holder or proprietor of, a Community trade mark or the applicant for, or holder of, a registered Community design, but also to the opponent, the applicant for a declaration of revocation or invalidity, or an alleged infringer who is joined as a party to invalidity proceedings pursuant to Article 54 CDR.

The time limit must have been missed by the party concerned or their representative.

3.3 Time limit for national offices to forward an application to the Office

Article 25(2) CTMR Articles 35(1) and 38(2) CDR
--

The time limit of one month for transmission of a CTM application or two months for transmission of a Community design application filed at a national Office has to be observed by the national Office and not by the applicant and is consequently not open to *restitutio in integrum*.

Under Article 38(2) CDR, late transmission of a Community design application has the effect of postponing the date of filing to the date the Office actually receives the relevant documents.

Furthermore, if the time limit under Article 25(3) CTMR for transmission of a CTM application is not met, rather than considering the CTM application as having been withdrawn, the Office will treat the CTM application as if it had arrived at the Office direct from the applicant and not via a national Office. As a result, the filing date will be the date OHIM actually receives it.

3.4 Time limits excluded from *restitutio in integrum*

Article 81(5) CTMR Article 67(5) CDR

In the interest of legal certainty, *restitutio in integrum* is not applicable to the following time limits.

Articles 29(1) and 81(5) CTMR
Rule 6(1) CTMIR
Articles 41(1) and 67(5) CDR
Article 8(1) CDIR

- The priority period, which is the six-month time limit for filing an application claiming the priority of a previous trade mark or design application pursuant to Article 29(1) CTMR or Article 41(1) CDR. However, *restitutio* does apply to the three-month time limit for providing the file number of the previous application and filing a copy of it, as specified in Rule 6(1) CTMIR or Article 8(1) CDIR.

Articles 41(1), (3) and 81(5) CTMR

- The time limit for filing an opposition pursuant to Article 41(1) CTMR, including the time limit for paying the opposition fee referred to in Article 41(3) CTMR.

Article 81(2), (5) CTMR
Article 67(2), (5) CDR

- The time limits for *restitutio* itself, namely:
 - a time limit of two months for filing the application for *restitutio in integrum* as from the removal of the cause of non-compliance
 - a time limit of two months from the date for completing the act that was omitted
 - a time limit of one year for filing the application for *restitutio in integrum* as from expiry of the missed time limit.

3.5 Effect of *restitutio in integrum*

Granting *restitutio in integrum* has the retroactive legal effect that the time limit that was not met will be considered to have been met, and that any loss of rights in the interim will be deemed never to have occurred. If the Office takes a decision in the interim based on failure to meet the time limit, that decision will become void, with the consequence that, once *restitutio* is granted, there is no longer any need to lodge an appeal against such a decision of the Office in order to have it removed. Effectively, *restitutio* will re-establish all the applicant's rights.

3.6 Time limit

Articles 47(3) and 81(2) CTMR
Articles 13(3) and 67(2) CDR

Applicants must apply for *restitutio in integrum* in writing and send the application to the Office.

The applicant must make the application within two months of the removal of the cause of non-compliance and no later than one year after expiry of the missed time limit.

Within the same period, the act that was omitted must be completed. The date when the cause of non-compliance is removed is the first date on which the party knew or should have known about the facts that led to the non-observance. If the ground for non-compliance was the absence or illness of the professional representative dealing with the case, the date on which the cause of non-compliance is removed is the date on which the representative returns to work. If the applicant fails to submit a request for renewal or to pay the renewal fee, the one-year time limit starts on the day on which the protection ends, and not on the date the further six-month time limit expires.

3.7 Fee

Article 81(3) CTMR
Article 2(19) CTMFR
Article 67(3) CDR
Annex, point 15 CDFR

The applicant must also pay the fee for *restitutio in integrum* within the same time limit (see paragraph 3.6). If the applicant does not pay the fee by the expiry of the time limit, the application for *restitutio in integrum* will be deemed not to have been filed.

3.8 Languages

Article 119 CTMR
Rule 95 CTMIR
Article 98 CDR
Article 80 CDIR

The applicant must submit the application for *restitutio in integrum* in the language, or in one of the languages, of the proceedings in which the failure to meet the time limit occurred. For example, in the registration procedure, this is the first language indicated in the application; in the opposition procedure, it is the language of the opposition procedure; and in the renewal procedure, it is any of the Office's five languages.

3.9 Particulars and Evidence

Articles 78 and 81 CTMR
Articles 65 and 67 CDR

In its application for *restitutio* the applicant must state the grounds on which it is based and set out the facts on which it relies. As granting *restitutio* is essentially based on facts, it is advisable for the requesting party to adduce evidence by means of sworn or affirmed statements.

Moreover, the act that was omitted must be completed, together with the application for *restitutio*, at the latest by the time limit for submitting the application for *restitutio*.

3.10 Competence

Article 81 CTMR
Article 67 CDR

The division or department competent to decide on the act that was omitted (i.e. responsible for the procedure in which failure to meet the deadline occurred) is responsible for dealing with applications for *restitutio*.

3.11 Publications

Article 81(7) CTMR
Rule 30(4), (5), Rule 84(3)(k), (l) and Rule 85(2) CTMR
Article 67 CDR
Article 22(4), (5), Article 69(3)(m), (n) and Article 70(2) CDIR

The CTMR and CDR provide for a mention of the re-establishment of rights to be published in the Bulletin. This mention will be published only if the failure to meet the time limit that gave rise to the application for *restitutio* has actually led to publication of a change of status of the CTM or CD application or registration, because only in such a case would third parties be able to take advantage of the absence of such rights. For example, the Office will publish a mention that *restitutio* has been granted if it published a mention that registration had expired due to failure to meet the time limit for paying the renewal fee.

In the event of such a publication, a corresponding entry will also be made in the Register.

No mention of receipt of an application for *restitutio* will be published.

3.12 Decision, role of other parties in *restitutio* proceedings

Articles 58 and 59 CTMR

The applicant for *restitutio in integrum* is the sole party to the *restitutio* proceedings, even where failure to meet the time limit occurred in *inter partes* proceedings.

The decision on *restitutio* will be taken, if possible, in the decision terminating the proceedings. If, for specific reasons, the Office makes an interim decision on the application for *restitutio*, it will generally not allow a separate appeal. The applicant for *restitutio* can appeal the refusal of its request for *restitutio* together with an appeal against the decision terminating the proceedings.

The decision to grant *restitutio* cannot be appealed.

The other party to *inter partes* proceedings will be informed that *restitutio* has been requested and about the outcome of the proceedings. If *restitutio* is actually granted, the other party's only means of redress is to initiate third-party proceedings (see below, paragraph 4).

4 Third-Party Proceedings

Article 81 CTMR Article 67 CDR

A third party who, in the period between the loss of right and publication of the mention of the re-establishment of rights,

- has, in good faith, put goods on the market or supplied services under a sign that is identical or similar to the CTM, or
- in the case of a Community design, has, in good faith, put on the market products in which a design included within the scope of protection of the RCD is incorporated or to which it is applied,

may bring third-party proceedings against the decision re-establishing the rights of the applicant, proprietor or holder of the CTM or RCD.

This request is subject to a two-month time limit which starts:

- on the date of publication, where publication has taken place,
- on the date on which the decision to grant *restitutio* took effect, where publication has not taken place.

The Regulations do not contain any provisions governing this procedure. The department or unit that took the decision to re-establish the rights is responsible for third-party proceedings. The Office will conduct adversarial *inter partes* proceedings.

***GUIDELINES FOR EXAMINATION IN THE
OFFICE FOR HARMONIZATION IN THE
INTERNAL MARKET (TRADE MARKS AND
DESIGNS) ON COMMUNITY TRADE MARKS***

PART A

GENERAL RULES

SECTION 9

ENLARGEMENT

Table of Contents

1	Introduction.....	3
2	Rules Concerning Examination.....	3
2.1	Automatic Extension of CTMs to New Member States	3
2.2	Pending CTM Applications	3
2.3	Distinctiveness Acquired Through Use	4
2.4	Bad Faith.....	4
2.5	Conversion.....	5
2.6	Other Practical Consequences.....	5
2.6.1	Filing at national Offices	5
2.6.2	Professional representation.....	5
2.6.3	First and second language	5
2.6.4	Translation.....	5
2.6.5	Seniority.....	6
2.6.6	Search	6
3	Rules Concerning Oppositions and Cancellations.....	6
	Annex 1	9

1 Introduction

This chapter discusses the rules relating to the accession of new Member States to the European Community and the consequences for holders of Community trade marks. Both absolute and relative grounds are dealt with in this chapter.

Article 165 CTMR contains the relevant provisions relating to enlargement and Community trade marks. These provisions were introduced into the Regulation pursuant to the 2004 enlargement process (at that time Article 147a CTMR) and have remained unchanged during successive enlargement processes. The only modification in the text of the Regulation is the addition of the names of the new Member States.

A table in Annex 1 lists the new Member States along with their accession dates and official languages.

2 Rules Concerning Examination

2.1 Automatic Extension of CTMs to New Member States

Article 165(1) CTMR lays down the basic rule of enlargement, which is that all existing CTM applications and registered CTMs are automatically extended to the new Member States without any kind of additional intervention by OHIM, any other body or the holders of the rights concerned. There is no need to pay any extra fees or complete any other administrative formality. The extension of existing CTM applications or CTMs to the territories of new Member States ensures that these rights have equal effect throughout the EU and complies with the fundamental principle of the unitary character of the CTM.

2.2 Pending CTM Applications

Article 165(2) CTMR enshrines an important transitional provision, according to which CTM applications **pending on the accession date** may not be refused on the basis of any absolute ground for refusal if this ground becomes applicable merely because of the accession of a new Member State ('grandfathering clause'). In practice, this means that if a CTM application is non-distinctive, descriptive, generic, deceptive or contrary to public policy or morality in the language or in the territory of a new Member State, it will not be refused if its filing date is **before** this State's accession date.

For applications filed **after the accession date** the grounds for refusal of Article 7(1) CTMR apply also for the new Member State. This is the case even when the CTM application has a priority date which is earlier than the relevant accession date. The priority right does not protect the CTM applicant against any change in the law relevant to its application. Therefore, examiners have to apply the same examination criteria as for all the other official languages of the EU. This means that the examiner has to check if the CTM application is descriptive, etc. also in the new Member State.

However, this principle should be applied with caution as it merely means that the criteria for applying Article 7(1) CTMR should not be made stricter as a result of the accession of new Member States. The inverse conclusion that terms which are descriptive in a language or in the territory of a new Member State may, in any case, be registered for CTM applications filed prior to the accession date will not always be

correct. For example, descriptive terms from new Member States' languages may have entered the customary languages of existing Member States or be widely known in them (for example, Vodka), and geographical indications may already have to be refused as descriptive terms (for example, Balaton or Tokaj). Consideration must also be given to geographical indications already protected in the new Member States and to protection arising from Community legislation or bilateral treaties between the new Member States and the EU or existing Member States.

More precisely, the grounds for refusal of Article 7(1)(f) and (g) CTMR, relating to marks contrary to public policy or morality and deceptive marks respectively, are only affected by this provision insofar as the deceptiveness or breach of public morality is due to a meaning which is **only** understood in a language of a new Member State. The Office interprets Article 7(1)(f) CTMR in accordance with Community-wide criteria, irrespective of the relative levels of morality in different countries of the EU.

Finally, the provision of Article 165(2) CTMR does not affect the grounds for refusal of Article 7(1)(e) or (i) CTMR: the former relates to signs consisting exclusively of the shape of the goods themselves, the shape which is necessary to obtain a technical result or the shape which gives substantial value to the goods, and the latter relates to badges and emblems not protected by Article 6ter of the Paris Convention but of particular public interest.

2.3 Distinctiveness Acquired Through Use

According to Office practice, distinctiveness acquired through use (Article 7(3) CTMR) must exist on the CTM filing date and subsist until its registration date. Where an applicant for a CTM application filed **before** the accession date is able to demonstrate that acquired distinctiveness existed at the filing date, Article 165(2) CTMR precludes an objection based on the ground that it is not distinctive through use in the new Member States. Therefore, the applicant does not have to prove acquired distinctiveness in the new Member States.

2.4 Bad Faith

The Office will consider the filing of a CTM application as having been made in bad faith if it was made prior to the accession date for a term which is descriptive or otherwise not eligible for registration in the language of a new Member State for the sole purpose of obtaining exclusive rights to a non-registrable term or for otherwise objectionable purposes.

This has no practical effect during the examination stage as bad faith does not constitute an absolute ground for refusal and, consequently, the Office has no authority to object *ex officio*. The Office will exercise its duties in respect of 'bad faith filings' only when a request for a declaration of invalidity is filed (Article 52(1)(b) CTMR). The national Offices of the new Member States are equally determined to act against bad faith in the context of enlargement. CTM applicants should, therefore, bear in mind that, even if there are no grounds for refusal during the registration procedure, their CTM registrations may be contested at a later date on the basis of Article 52(1)(b) CTMR.

2.5 Conversion

Conversion of a CTM application into national trade mark applications for new Member States may be requested as from the accession date of those States. Conversion is also possible when a converted CTM has a filing date prior to the accession date. However, in the case of a new Member State, the converted application will have the effect of an earlier right under national law. National law in new Member States has enacted provisions equivalent to Article 165 CTMR providing that extended CTMs have the effect of earlier rights in the new Member States only with effect from the accession date. In practice, this means that the 'conversion date' in a new Member State cannot be earlier than that State's accession date.

Taking Croatia's accession as an example, this means that even if a converted CTM has a filing date of 01/05/2005 in Croatia, the conversion date will not be 01/05/2005 but 01/07/2013, that is, Croatia's accession date.

The date of enlargement does not trigger a new three-month time limit for requesting conversion under Article 112(4) CTMR.

2.6 Other Practical Consequences

2.6.1 Filing at national Offices

As from the accession date of a new Member State, a CTM application may also be filed through that State's national Office.

2.6.2 Professional representation

As from the accession date of a new member State, applicants (as well as other parties to proceedings before the Office) having their seat or domicile in that State need no longer be represented by a professional representative. As from the accession date of a new Member State, professional representatives from that State may be entered on the list of professional representatives maintained by the Office pursuant to Article 93 CTMR and may then represent third parties before the Office.

2.6.3 First and second language

As of the accession date of a new Member State (see Annex 1), the official language(s) of that State may be used as the first language for CTM applications filed on or after that date.

2.6.4 Translation

CTM applications with a filing date prior to the accession date of a new Member State and existing CTM registrations will be neither translated into nor republished in the language of that State. CTM applications filed after the accession date of a new Member State will be translated into and published in all official languages of the EU.

2.6.5 Seniority

Seniority may be claimed from a national trade mark which was registered before the accession of the new Member State in question or even before the creation of the European Union. The seniority claim may, however, only be made after the accession date. The mark registered in the new Member State must be 'earlier' than the CTM. As an extended CTM has, in the new Member State, the effect of an earlier right as from the accession date, the seniority claim only makes sense when the earlier national mark has a filing or priority date prior to the accession date.

Example 1: The same person files a CTM application on 01/04/1996 and a national trade mark application in Romania on 01/01/1999. After 01/01/2007 (Romania's date of accession) the seniority of the Romanian national trade mark application may be claimed.

Example 2: The same person owns an international registration designating the EU on 01/01/2005 and subsequently designating Romania on 01/01/2006. After 01/01/2007, the seniority of that Romanian designation may be claimed even though the designation itself is later than the IR designating the EU. This is because the extended CTM takes effect from the accession date of the new Member State (in this case 01/01/2007).

2.6.6 Search

The national Offices of a new Member State may carry out searches (Article 38(2)(3) CTMR) as from that State's accession date. Only CTM applications with a filing date on or after the accession date are sent to national Offices for a search.

3 Rules Concerning Oppositions and Cancellations

1. According to Article 165(4)(b) CTMR, a CTM application cannot be opposed or declared invalid on the basis of a national earlier right acquired in a new Member State prior to that State's accession date.

However, CTM applications filed on or after the accession date are not subject to this 'grandfathering clause' and may be rejected upon opposition, or declared invalid, on account of an earlier national right existing in a new Member State, provided that the earlier right is 'earlier' when the two filing or priority dates are compared.

2. An exception to this (transitional) rule is contained in Article 165(3) CTMR regarding oppositions. A CTM application, filed within the six months preceding the accession date, may be challenged by an opposition based on a national right existing in a new Member State at the date of the accession, provided that this right
 - a) has an earlier filing or priority date and
 - b) was acquired in good faith.
3. The filing date and not the priority date is the decisive element for determining when a CTM application can be opposed on the basis of an earlier right in a new Member State. In practice, the abovementioned provisions have the

consequences illustrated in the following examples with reference to the accession of Croatia (01/07/2013):

- a) A CTM application filed before 01/01/2013 (the priority date is irrelevant in this context) cannot be opposed or declared invalid on the basis of a national earlier right in a new Member State under any circumstances.
- b) A CTM application with a filing date between 01/01/2013 and 30/06/2013 (i.e. **during the six months prior to the date of accession**), may be opposed by a Croatian trade mark, provided that the filing or priority date of the Croatian trade mark is earlier than the filing or priority date of the opposed CTM application and the national mark was applied for in good faith.
- c) A CTM application with a filing date of 01/07/2013 or later may be opposed or declared invalid on the basis of a trade mark registered in Croatia if that mark has an earlier filing or priority date under the normal rules. Acquisition in good faith is not a condition. This applies to all national marks and earlier non-registered rights filed or acquired in a new Member State prior to accession.
- d) A CTM application with a filing date of 01/07/2013 or later but with a priority date before 01/07/2013 may be opposed or declared invalid on the basis of a national trade mark registered in Croatia if that mark has an earlier filing or priority date under the normal rules.

This transitional exception is limited to the right to file an opposition and does not include the right to file an application for cancellation based on relative grounds. This means that once the abovementioned period of six months has expired without an opposition having been lodged, the CTM application cannot be challenged any more by an opposition or by an application for a declaration of invalidity.

4. According to Article 165(5) CTMR, the **use** of a CTM with a filing date prior to the date of accession of a new Member State, may be prohibited pursuant to Articles 110 and 111 CTMR on the basis of an earlier national trade mark registered in the new Member State where the latter has a filing or priority date prior to the date of accession and was registered in good faith.

The above provision also applies to:

- applications for national marks filed in new Member States, provided that they have subsequently been registered,
 - unregistered rights acquired in new Member States falling under Article 8(4) or Article 53(2) CTMR with the proviso that the date of acquisition of the right under national law replaces the filing or priority date.
5. Where an opposition is based on a national registered mark or other right in a new Member State, whether or not that right may be validly invoked as a ground for opposition against a CTM application depends on whether the opposition is well founded and is not an issue of admissibility.
 6. The acquisition in good faith of the earlier national mark is presumed. This means that, if good faith is questioned, the other party to the proceedings (the applicant

for the opposed CTM application in the case of Article 165(4) CTMR or the owner of the registered CTM in the case of Article 165(5) CTMR) must prove that the owner of the earlier national right obtained in a new Member State acted in bad faith when filing the national application or otherwise acquiring the right.

7. Article 165 CTMR does not contain any transitional provisions concerning the use requirement (Articles 15 and 42 CTMR). In opposition proceedings, the obligation to make genuine use of the mark arises when the applicant for the opposed CTM application requests that the opponent prove use of the earlier mark pursuant to Article 42(2) and (3) CTMR and Rule 22 CTMIR. Issues relating to enlargement could arise regarding the time and place of use of the earlier mark.

Two cases can be distinguished:

- a) The earlier mark is a national mark registered in a new Member State

In this case the opponent must prove genuine use of the earlier mark. This situation can only arise in the context of an opposition directed either against a CTM application with a filing date after the date of accession or against a CTM application filed within the period of six months preceding the date of accession.

The earlier national mark must have been put to genuine use in the territory in which it is protected during the five years preceding the date of publication of the opposed CTM application. In this regard, it is immaterial whether the use relates to a period during which the State concerned was already a Member of the European Union. In other words, the proof of use may relate also to a period prior to the date of accession (in the case of Croatia before 01/07/2013).

- b) The earlier mark is a CTM

Where the owner of the earlier CTM can prove use only in the territory of a new Member State or several new Member States, since the obligation of use relates to the period of five years preceding the date of publication of the opposed CTM application, use in a new Member State (or several new Member States) can only be taken into account if the State concerned was a Member State of the European Union at the date of publication of the opposed CTM application (Article 43(1) CTMR requires use 'in the Community'). Before their accession dates, the new States do not constitute 'Member States of the Community'; therefore, it is not possible to prove use 'in the Community'.

Therefore, the five-year period should be counted only from the relevant date of accession.

8. There are no particular transitional problems relating to the opposition proceedings. The right pursuant to Article 119(7) CTMR to choose a language which is not one of the five languages of the Office as the language of the proceedings applies as from the date of accession in respect of the other official languages of the European Union.

Annex 1

Member States	Accession date	Languages
Czech Republic, Cyprus, Estonia, Latvia, Lithuania, Hungary, Malta, Poland, Slovakia, and Slovenia).	01/05/2004	Czech, Estonian, Hungarian, Latvian, Lithuanian, Maltese, Polish, Slovak and Slovenian
Bulgaria and Romania	01/01/2007	Bulgarian and Romanian
Croatia	01/07/2013	Croatian

***GUIDELINES FOR EXAMINATION IN THE
OFFICE FOR HARMONIZATION IN THE
INTERNAL MARKET (TRADE MARKS AND
DESIGNS) ON COMMUNITY TRADE MARKS***

PART B

EXAMINATION

SECTION 1

PROCEEDINGS

Table of Contents

1	Introduction: General Overview of Examination Proceedings	3
2	Search.....	4
2.1	Community search.....	4
2.2	National search	4
3	General Principles Concerning Examination Proceedings.....	5
3.1	Procedural aspects concerning third-party observations and review of absolute grounds.....	5
3.2	Decisions.....	6
3.2.1	Appeals.....	6
3.3	International registrations designating the European Union.....	6
4	Publication	7
5	Amendments to the CTM Application	7
5.1	Withdrawal of the CTM application.....	8
5.1.1	Declaration of withdrawal.....	8
5.1.2	Unconditional and binding character of the declaration	9
5.1.3	Action to be taken	9
5.2	Restriction of the list of goods and services in a CTM application.....	9
5.2.1	Procedural admissibility of a restriction	10
5.3	Other amendments	10
5.3.1	Name, address and nationality of applicant or representative	11
5.3.2	Other elements of an application.....	12
5.3.3	Recording and publication of amendments	12
5.4	Division of the CTM application.....	12
5.4.1	Requirements	13
5.4.2	Acceptance	14
5.4.3	New file and its publication	14

1 Introduction: General Overview of Examination Proceedings

This part of the Guidelines outlines the examination procedure from filing to publication of the Community trade mark (CTM) application.

Once the CTM application has been filed, a provisional filing date is accorded, and the Office issues a receipt. At this early stage, the Office only checks whether certain filing date requirements of the Community Trade Mark Regulation (CTMR) have been fulfilled. The filing date will only become definitive when the application fee has been paid.

The applicant should carefully check the receipt and notify the Office of any incorrect data. The applicant can only correct data that have an impact on the filing date, such as the applicant's name, the representation of the mark and the list of goods and services, if it notifies the Office on the same date as the incorrect data were submitted. After this date, any amendment is subject to the provisions of the CTMR and CTMIR, in particular, Article 17 CTMR and Article 43 CTMR. For further details, see paragraph 5 below and the Guidelines, Part B, Examination, Section 2, Examination of Formalities.

After the receipt has been issued, the Office carries out a language check of the verbal elements of the mark in all the official languages of the EU, followed by a Community search.

Payment of the application fee and national search fee (if applicable) is validated at the latest one month after the CTM application has been filed. If the applicant has applied for a national search and paid the relevant fee, the Office forwards the application to the offices of the Member States that perform national searches. For further information on searches, see paragraph 2 below. For further information on fees, see the Guidelines, Part A, General Rules, Section 3, Payment of Fees, Costs and Charges.

During examination proceedings, the Office examines the following: filing date, formalities, classification, priority and/or seniority, where applicable, the regulations governing use of the mark for collective marks and absolute grounds for refusal. All these examination steps can be carried out in parallel as there is no strict sequence in examination proceedings.

Any deficiency is notified to the applicant, who is given two months within which to remedy the deficiency and/or submit observations. Any decision partially or wholly refusing a CTM application must give the grounds on which the CTM application is refused and inform the applicant of its right to appeal. For further details, see paragraphs 3.2 and 3.2.1 below.

Applications that comply with the requirements of the Regulation are accepted for publication and sent for translation into all the official languages of the EU.

The last step in the examination procedure is publication of the application in Part A of the CTM Bulletin. Publication takes place one month after notification of the search reports (Community search and national search, if requested), giving the applicant the opportunity to abandon its application, if it so wishes. For further details on publication, see paragraph 4 below.

2 Search

Article 38 CTMR
Rule 5a and Rule 10 CTMIR
Communications 4/99, 5/00 and 4/01 of the President of the Office

The search report identifies earlier rights that could conflict with the CTM application. However, even if the search report does not indicate any similar earlier rights, an opposition could still be filed against the CTM application after its publication.

The results of the search report are for information purposes only and to give the applicant the option of withdrawing the CTM application before it is published. Surveillance letters inform holders of earlier Community trade marks about new, similar Community trade mark applications.

Figurative elements are classified under the Vienna Classification.

2.1 Community search

After issuing the receipt, the Office draws up a Community search report covering:

1. CTM applications with a filing date or priority date earlier than that of the application in question;
2. Community trade marks already registered; and
3. prior international registrations designating the European Union.

The Community search takes into account the filing date, the verbal elements of the trade mark, the figurative elements of the mark (if applicable) and the classes of goods and services according to the Nice Classification. The search is designed to identify similar earlier marks filed for the same classes or classes considered by the Office to contain similar goods and/or services.

The Community search report is sent to the applicant in a standard letter or electronically. Once the new application has been published, the Office sends a surveillance letter to the holders of earlier Community trade marks or Community trade mark applications cited in the search report.

2.2 National search

CTM applications that include a valid request for national searches are sent to the participating national offices once a filing date has been accorded and the classification has been validated. A request is valid if it is made at the time of filing and the relevant fee has been paid.

National search reports are prepared by offices that participate in the search system.

A request for national searches implies that all participating national offices will carry out the search within two months in accordance with Rule 5a CTMIR. This all-or-nothing approach means that the applicant cannot select the particular participating offices that it wishes to carry out the search.

Holders of international registrations (IR) designating the EU that wish to apply for national searches must send the request and pay the relevant fee to OHIM within one month of the date of notification of the IR from the World Intellectual Property Organization (WIPO).

The national offices are responsible for the format and content of the national search report. The Office's role is limited to receiving the national reports and forwarding them, together with the Community search report. The applicant is free to request further information directly from the national offices.

3 General Principles Concerning Examination Proceedings

This section describes only the procedural aspects of examining Absolute Grounds (AG) for refusal. For substantive aspects of examining Absolute Grounds for refusal, see the Guidelines, Part B, Examination, Section 4, Absolute Grounds for Refusal, Collective Marks, Acquired Distinctiveness.

The CTMR is intended to enable proprietors to register a right that is valid throughout the European Union provided it does not impinge on the rights of others. Although rights can only be conferred in accordance with the provisions of the CTMR, the Office's function is to facilitate applications, not obstruct them.

During the examination of each application, the trade mark **and** the goods or services of the application must be taken into account. The Office has to bear in mind the nature of the trade concerned, the manner in which the goods or services are provided and the relevant public, for example whether specialists or the general public.

3.1 Procedural aspects concerning third-party observations and review of absolute grounds

Article 40 CTMR Communication 2/09 of the President of the Office
--

Observations on the existence of an absolute ground for refusal can be made by third parties once an application has been published. Third-party observations received before a CTM application has been published are dealt with during the examination of absolute grounds for refusal. The Office accepts observations received within the opposition period (three months from the date of publication) or filed before pending oppositions are closed. The observations must be filed in one of the Office's languages: English, French, German, Italian or Spanish.

The Office issues a receipt to the party that submitted the observations (the observer), confirming that the observations have been received and have been forwarded to the applicant. The observer does not become a party to the proceedings before the Office but can consult the online search tools to check the status of the relevant CTM application. The Office does not inform the observer of any action taken, or whether or not the observations have given rise to an objection.

All observations are forwarded to the applicant, who is invited to submit comments, where appropriate. The Office considers whether the observations are well founded, that is, whether an absolute ground for refusal exists. If so, the Office issues an objection and may refuse the CTM application if the objection is not overcome by the applicant's comments or by a restriction of the list of goods and services.

If an issue raised in observations has already been considered during the examination of an application, it is unlikely to give rise to serious doubts after publication.

The Office may also re-open the examination on absolute grounds on any other ground and at any time prior to registration, for example when third-party observations are filed before the application is published or when the Office itself finds that a ground for refusal has been overlooked. After the application is published, this option should be exercised only in clear-cut cases.

For more information, see the Guidelines, Part B, Examination, Section 4, Absolute Grounds for Refusal.

3.2 Decisions

In all cases where the Office issues decisions against applicants, it must give the grounds for the decision. These must address any arguments raised by the applicant in its observations if they are pertinent. Decisions must not only refer to the appropriate parts of the CTMR and CTMIR but also give explicit reasons, except in the most self-evident cases (for example, where a document is missing or a fee has not been paid).

Where, for example, a decision is given on the basis of internet searches, the Office must provide the applicant with proof of those searches.

3.2.1 Appeals

Articles 58 and 65 CTMR
Decision 2009-1 of 16/06/2009 of the Presidium of the Boards of Appeal

Applicants have a right to appeal against a decision that terminates proceedings and that adversely affects them. For practical purposes, any decision issued by the Office that terminates proceedings and is not accepted by the applicant falls into this category. Any written communication of such a decision must also inform the applicant that the decision can be appealed within two months.

Appeals have suspensive effect. Within the period in which an appeal can be lodged, the Office should not take any steps that cannot easily be reversed (e.g. publication or entry in the Register). The same goes for the period up until a final decision is taken where a case is brought before the General Court (GC) or Court of Justice of the European Union (CJEU) by an action under Article 65.

3.3 International registrations designating the European Union

Details about the examination of a CTM application as a result of the transformation of an international registration designating the European Union are given in the Guidelines, Part M, International Marks.

4 Publication

Article 39 CTMR
Rules 12, 14 and 46 CTMIR

Publication takes place once the search reports have been sent to the applicant, provided that the application fulfils all the acceptance conditions.

Applications are published in all the official languages of the EU.

The examiner must ensure that the following details are available, where applicable:

- (a) application file number
- (b) filing date
- (c) reproduction of the trade mark
- (d) indication of the collective mark
- (e) indication of the mark type other than word marks, for example figurative marks, three-dimensional marks, holograms, sound marks, colour per se marks and other marks
- (f) description of the mark
- (g) colour indication(s)
- (h) figurative elements under the Vienna Classification
- (i) disclaimer
- (j) acquisition of distinctive character through use
- (k) applicant's name, address and nationality
- (l) representative's name and address
- (m) first and second language
- (n) goods and services under the Nice Classification
- (o) priority data, if applicable
- (p) exhibition priority data
- (q) seniority data
- (r) transformation data.

Once the examiner has checked that all these elements are correct and the Office has received the translation in all the official languages of the EU, the application is dispatched to the Publication Team.

5 Amendments to the CTM Application

This part of the Guidelines only covers issues that are relevant to CTM application amendments.

For amendments to registered Community trade marks, see the Guidelines, Part E, Register Operations, Section 1, Changes in a registration.

5.1 Withdrawal of the CTM application

Article 43, Articles 58(1), 64(3), 65(5) and Article 119 CTMR
Article 101 and Article 102(2) Rules of Procedure of the General Court (RPGC)
Article 51 Rules of Procedure of the Court of Justice (RPCJ)

5.1.1 Declaration of withdrawal

A CTM application can be withdrawn at any time up until a final decision is taken on its subject matter.

After the Office's first-instance decision, an application can be withdrawn at appeal level within the two-month appeal period, even if no appeal was actually filed or up until the appeal is decided by the Board of Appeal; this applies both to *ex parte* and *inter partes* proceedings (decision of 27/09/2006, R 0331/2006-G – 'Optima' and decision of 23/04/2014, R 0451/2014-1 – 'SUPERLITE', para. 18).

At the level of the General Court (GC), an application can be withdrawn within the two-month appeal period extended by a period of ten days (on account of distance) pursuant to Article 102(2) RPGC. At the level of the Court of Justice of the European Union (CJEU), the prescribed time-limit of two months to bring an action before the CJEU against a decision by the Boards of Appeal shall be extended on account of distance by a single period of 10 days (order of 19/07/2003, T-15/03, 'BLUE'). The Boards of Appeal decision cannot be considered final within this period. The application can also be withdrawn up until completion of the appeal process before the GC.

At CJEU level, an application can be withdrawn within the two-month period for filing an appeal before the CJEU extended by a period of ten days (on account of distance) pursuant to Article 51 RPCJ or before the CJEU has issued a final and binding decision (order of 18/09/2012, C-588/11, 'OMNICARE').

When the case is pending before the GC or the CJEU, the applicant must ask the Office (not the GC or CJEU) to withdraw it. The Office then informs the GC or CJEU whether or not it finds the withdrawal acceptable and valid, but the withdrawal will not take place until the GC or the CJEU has delivered a final decision on the issue (by analogy, see judgment of 16/05/2013, T-104/12, 'Vortex').

Any declaration of withdrawal filed after the expiry of the appeal period is inadmissible.

There is no charge for a declaration of withdrawal but the declaration must be made in writing. No special form is provided by the Office.

The declaration of withdrawal can be made in the first or second language indicated by the applicant in its CTM application. The same applies during opposition proceedings. However, for the procedure in cases where a restriction is made in a language other than the language of the opposition procedure, see the Guidelines, Part C, Opposition, Section 1, Procedural Matters.

For details of restrictions see paragraph 5.2 below.

Although Article 43(1) CTMR refers only to withdrawal of a Community trade mark application, the Court has held that oppositions can also be withdrawn in the same way as described above (decision of 07/07/2014, R 1878/2013-1 - 'HOT CHILLYS', para. 15).

5.1.2 Unconditional and binding character of the declaration

A declaration of withdrawal becomes effective upon receipt by the Office, provided that the Office does not receive a withdrawal of the declaration on the same day.

This means that if a declaration of withdrawal and a letter withdrawing that declaration both reach the Office on the same day (regardless of the actual time of receipt), the latter annuls the former.

Once a declaration becomes effective, it cannot be withdrawn.

A declaration of withdrawal is void where it contains conditions or time limitations. For example, it must not require the Office to take a particular decision or, in opposition proceedings, require the other party to make a procedural declaration. Such a requirement is simply viewed as a suggestion for resolving the case; the Office informs the opponent accordingly and may invite the parties to come to an amicable settlement. Furthermore, a declaration does not become effective if it is made for some goods and/or services (partial withdrawal) on condition that the Office accepts the application for the remaining goods and/or services. Such a declaration is simply viewed as a suggestion to enable the Office to arrive at an acceptable list of goods and services.

Where an applicant responds to an official action by filing a restricted list of goods and services (partial withdrawal), the Office checks whether the applicant is declaring the unequivocal withdrawal of the remaining goods and services or whether the amended list of goods and services is a proposal or counterproposal by the applicant, subject to the Office's agreement.

5.1.3 Action to be taken

The Office will process a declaration of withdrawal, ensure publication of the full or partial withdrawal in the Bulletin, if the CTM application has already been published and close the CTM application file in the event of a full withdrawal.

For the consequences of full or partial withdrawal on the opposition procedure, see the Guidelines, Part C, Opposition, Section 1, Procedural Matters.

Detailed information on the refund of application fees can be found in the Guidelines, Part A, General Rules, Section 3, Payment of Fees, Costs and Charges.

5.2 Restriction of the list of goods and services in a CTM application

Articles 43 and 119 CTMR

The applicant may restrict the list of goods and services of its CTM application at any time, either of its own volition, in response to an objection regarding classification or absolute grounds, or in the course of opposition proceedings.

In principle, declarations of restrictions follow the same rules as declarations of withdrawals; see paragraph 5.1 above.

Where the case is pending before the General Court (GC) or the Court of Justice (CJEU), the restriction must be filed with the Office (not with the GC or the CJEU). The Office then informs the GC or the CJEU whether or not it finds the restriction acceptable and valid; however, the restriction is not applied until the GC or the CJEU has delivered a final decision on the issue (by analogy, see judgment of 16/05/2013, T-104/12, 'Vortex').

5.2.1 Procedural admissibility of a restriction

The restriction must be procedurally admissible; see paragraph 5.1.2 above.

As a matter of principle, a restriction becomes effective on the date on which the Office receives it. The restriction can only be withdrawn if the withdrawal is received on the same date as the restriction itself.

Two requirements must be met in order for a restriction to be acceptable:

1. The new wording must not constitute an extension of the list of goods and services.
2. The restriction must constitute a valid description of goods and services and apply only to acceptable goods or services that appear in the original CTM application. For further details on restrictions of a CTM application, see the Guidelines, Part B, Examination, Section 3, Classification.

If these requirements are not met, the Office must refuse the proposed restriction and the list of goods and services will remain unchanged (decision of 14/10/2013 R 1502/2013-4 - 'DARSTELLUNG EINES KREISES', paras 12-16).

5.3 Other amendments

Article 43(2) CTMR Rules 13 and 26 CTMIR

This paragraph and the legal provisions cited above solely concern amendments to the CTM application requested by the applicant on its own initiative and not amendments or restrictions made following an examination, opposition or appeal procedure as a result of a decision by an examiner, Opposition Division or Board of Appeal.

Nor does this paragraph apply to the correction of errors in the Office's publications, which is carried out *ex officio* pursuant to Rule 14 CTMIR.

Amendments require a written request in accordance with the language regime (for more information, see the Guidelines, Part B, Examination, Section 2, Examination of Formalities). There is no charge for this.

The following elements of a CTM application may be amended:

- the name and address of the applicant or representative (see paragraph 5.3.1 below);
- errors of wording or of copying, or obvious mistakes, provided that the correction does not substantially change the trade mark (for further details on such amendments, see the Guidelines, Part B, Examination, Section 2, Examination of Formalities);

- the list of goods and services (see paragraph 5.2 above).

5.3.1 Name, address and nationality of applicant or representative

Rule 1(1)(b) and (e), Rules 26 and 84 CTMIR Article 1(1)(b), Article 19(7) and Article 69(2)(d) CDIR

The name and address of an applicant or its appointed representative may be amended freely, provided that

- any change in the applicant's name is not the consequence of a transfer,

and

- as regards the name of a representative, the representative is not being substituted by another representative.

The indication of a legal person's nationality may also be amended freely, provided that it is not the consequence of a transfer.

A change in an applicant's name that does not affect the applicant's identity is an acceptable change, whereas a change in the applicant's identity is a transfer. For details and the applicable procedure in the event of doubt as to whether the change is considered to be a transfer, see the Guidelines, Part E, Register Operations, Section 3, CTMs as Objects of Property, Chapter 1, Transfer.

Changes to a representative's name are also limited to those that do not affect the identity of the appointed representative, for example where there is a change in the name (through marriage/divorce) of a representative or the name of an association of representatives. Such changes of name must be distinguished from the substitution of one representative by another, which is subject to the rules governing the appointment of representatives. For details concerning representatives, see the Guidelines, Part A, General Rules, Section 5, Professional Representation.

Changes of name, address or nationality may be the result of changed circumstances or of an error made at the time of filing.

The applicant or its representative must request a change of name and address and this request must contain the CTM application number and the name and address of the applicant or representative, both as recorded on the file and as amended.

No proof or evidence of the change is necessary. There is no charge for change of name or address requests.

The applicant must use a specific format in its application to indicate its name and official address in accordance with the aforementioned legal provisions, and may change it later using the same format. Both the name and address will be registered.

Legal persons can have only one official address. In case of doubt, the Office may ask for evidence of the legal form, the state of incorporation and/or address. The official name and address are taken, by default, as the address for service. Ideally, an applicant should have only one address for service. Changes to the applicant's official designation or official

address will be registered for all CTM applications, registered Community trade marks and Registered Community Designs and, unlike the address for service, cannot be recorded only for specific portfolios of rights. In principle, these rules also apply, by analogy, to representatives.

5.3.2 Other elements of an application

Other elements of a CTM application may also be changed, such as the representation, type of mark, description of the mark and disclaimers.

For example, in priority claims, obvious mistakes in the indication of the country in which, and the date on which, the earlier mark was filed may be corrected, since the priority document will obviously show the correct version.

For further details on these changes, see the Guidelines, Part B, Examination, Section 2, Examination of Formalities.

5.3.3 Recording and publication of amendments

Article 41(2) CTMR

If an amendment is allowed, it will be recorded in the file.

Where the CTM application has not yet been published, it is published in the CTM Bulletin in the amended form.

Where the CTM application has already been published and (only) if the amendment concerns the list of goods and services or the representation of the mark, the CTM application is published in its amended form in the CTM Bulletin. The publication of the amended application may open a new opposition period of three months.

Any other amendments are not published separately but appear in the publication of the registration.

5.4 Division of the CTM application

Article 44 CTMR Rule 13a CTMIR

A CTM application can be divided into different parts not only as a result of a partial transfer (see the Guidelines, Part E, Register Operations, Section 3, CTMs as Objects of Property, Chapter 1, Transfer), but also on the CTM applicant's own initiative. Division is particularly useful for isolating a disputed CTM application for certain goods or services while maintaining the original application for the remainder. For information on the division of CTMs, see the Guidelines, Part E, Register Operations, Section 1, Changes in a registration.

Whereas a partial transfer is free of charge and involves a change of ownership, there is a charge for a request for the division of a CTM application, and the CTM application remains in the hands of the same applicant. If the fee is not paid, the request is deemed not to have

been filed. The request can be made in the first or second language indicated by the applicant in its CTM application.

Division is not available for international registrations under the Madrid Protocol designating the EU. The international register is kept at WIPO, and OHIM does not have the authority to divide an international registration designating the EU.

5.4.1 Requirements

A request for division must contain the following information:

- the file number of the CTM application to be divided;
- the name and address or name and ID number of the applicant;
- the list of goods and services for the divisional application or, if more than one new application will be created, the list of goods and services for each divisional application;
- the list of the goods and services that will remain in the original CTM application.

Furthermore, the goods and services of the divisional application must not overlap with the list of goods and services of the original application.

The Office will notify the applicant of any deficiency in this regard and give it two months to remedy the deficiency. If it is not remedied within this time, the request for division will be refused.

There are certain periods during which, for procedural economy or to safeguard third-party rights, division is not admissible. These periods are outlined below.

1. While an opposition is pending, only the non-contested goods and services may be hived off. The same applies if the case is pending before the Boards of Appeal or the Courts. The Office interprets the legal provisions cited above as preventing the applicant from hiving off some or all of the contested goods to form a new application causing the opposition proceedings to be split. If such a request for division is made, the applicant is given the opportunity to amend it by hiving off the non-contested goods and services.
2. Division is not admissible during the three-month opposition period following publication of the application. Allowing a division during this time would counteract the aim of not splitting an opposition procedure and frustrate third parties, who have to rely on the CTM Bulletin to know what to oppose.
3. Division is not admissible during the period before a filing date has been issued either. This does not necessarily coincide with the first month following filing. For further details on the filing date, see the Guidelines, Part B, Examination, Section 2, Examination of Formalities.

For all practical purposes, in the period following publication of the application, division is only admissible if an opposition has been entered against the application and only for the non-contested part. The aim of the provisions cited is to allow the applicant to register its mark for the non-contested goods quickly, without having to wait for the outcome of a lengthy opposition procedure.

5.4.2 Acceptance

Article 44(6) CTMR

If the Office accepts the declaration of division, a new application is created as of the date of acceptance and not retroactively as of the date of the declaration.

The new application keeps the filing date and any priority and seniority dates. The seniority effect will then become partial.

All requests and applications submitted, and all fees paid, prior to the date on which the Office receives the declaration of division are also deemed to have been made or paid for the divisional application. However, fees duly paid for the original application are not refunded.

The practical effects of this provision are as follows:

- Where an application for the registration of a licence was made and payment of the registration fee was received by the Office prior to the declaration of division, the licence will be registered against the original registration and recorded in the file of the new registration. No further fees need be paid.
- Where a CTM application claiming six classes is to be divided into two applications of three classes each, no class fees are payable as of the date the Office receives the declaration of division. However, fees paid prior to that date cannot be refunded.

Where the division is not accepted, the old application remains unchanged. It does not matter whether:

- the declaration of division was deemed not to have been filed because no fee had been paid;
- the declaration was refused because it failed to comply with the formal requirements;
- the declaration was found inadmissible because it was filed during one of the periods in which division is not admissible.

The worst-case scenario for the applicant is that the declaration of division is not accepted, but this never affects the original application. The applicant can repeat the declaration of division later, on payment of a new fee.

5.4.3 New file and its publication

A new file has to be created for the divisional application, to contain all the documents that were on file for the original application, all the correspondence relating to the declaration of division and all future correspondence for the new application. Inspection of this file will be unrestricted under the general rules.

If the declaration of division concerns a CTM application that has not yet been published, both the divisional and the original application are published separately and in the normal way, without any express reference to each other.

If the declaration of division concerns a CTM application that has already been published, the fact that there has been a division is published with reference to the original application. The new application must also be published with all the usual particulars; however, no new opposition period will be opened. Division is admissible only for goods for which an opposition period has already started but not been made use of.

***GUIDELINES FOR EXAMINATION IN THE
OFFICE FOR HARMONIZATION IN THE
INTERNAL MARKET (TRADE MARKS AND
DESIGNS) ON COMMUNITY TRADE MARKS***

PART B

EXAMINATION

SECTION 3

CLASSIFICATION

Table of Contents

1	Introduction.....	3
2	The Nice Classification	3
3	Administrative Tools for Classification Purposes	4
4	Building a List of Goods and Services	5
4.1	Clarity and precision	5
4.1.1	General principles.....	5
4.1.2	Use of expressions (e.g. 'namely', 'in particular') to determine the scope of the list of goods/services	5
4.1.3	Use of the term 'and/or'	6
4.1.4	Punctuation.....	6
4.1.5	Inclusion of abbreviations and acronyms in lists of goods and services	7
4.2	Terms and expressions lacking clarity and precision	8
4.2.1	General indications of the class headings of the Nice Classification which are deemed not to be sufficiently clear and precise	8
4.2.2	Vague terms	11
4.2.3	The claim for all goods/services in this class or all goods/services of the alphabetical list in this class	12
4.2.4	Reference to other classes within the list	12
4.2.5	Trade marks in a list of goods/services	12
4.2.6	Inclusion of the terms <i>parts and fittings</i> ; <i>components</i> and <i>accessories</i> in lists of goods and services	13
4.2.7	Use of indefinite qualifiers	13
5	Procedure of Examination	13
5.1	Parallel applications.....	13
5.2	Objections.....	13
5.3	Amendments.....	14
5.4	Addition of classes.....	16
6	Annex 1.....	17

1 Introduction

Every CTM application must contain a list of goods and services as a condition for a filing date to be accorded (Article 26(1)(c) CTMR). The list must be classified in accordance with the Nice Agreement (Article 28 CTMR and Rule 2(1) CTMIR).

The list must be worded in such a way as to (a) indicate clearly the nature of the goods and services, and (b) allow each item to be classified in only one class of the Nice Classification (Rule 2(2) CTMIR).

The use of the Office's administrative IT tools for classification (see paragraph 3) is highly recommended. Any part of the list of goods and services which does not match the data from the tools will be examined following the principles as set out in these Guidelines. Whenever the applicant selects a term from the available tools, it will **not be examined** any further and will **speed up the registration procedure**.

The goods and services covered by a CTM application – including general indications of the class headings – will be interpreted by the Office on the basis of their natural and usual meaning. The former practice of the Office, according to which the use of all the general indications listed in the class heading of a particular class constituted a claim to all goods or services falling under the class was abandoned in June 2012, following the judgment of 19/06/2012, C-307/10, 'IP Translator'.

The purpose of this part of the Guidelines is to describe Office practice in the examination of classification of goods and services.

The first part (paragraphs 1 to 4) sets out the principles applied by the Office. The second part (paragraph 5) summarises the procedure of examining the list of goods and services.

In short, when examining the classification of a list of goods and services the Office does four tasks:

- it checks that each of the goods and services is clear and precise enough;
- it checks that each term is proper to the class in which it is applied for;
- it notifies any deficiency;
- it refuses the application, in whole or in part, where the deficiency is not remedied (Rule 9(4) and (8) CTMIR).

2 The Nice Classification

The version of the classification under the Nice Agreement in force at the filing date will be applied to the classification of the goods or services in an application (available at: <http://tmclass.tmdn.org>). Rule 2 requires the applicant to provide a list of goods and services in the following manner.

- The list must be worded in such a way as to indicate clearly the nature of the goods or services and to allow each item to be classified.
- The goods or services must be grouped according to the Nice Classification, each group preceded by the number of the class to which the goods or services belong and presented in the order of the classification.

The Nice Classification consists, for each class, of the following:

1. *Class headings*: the class headings are general indications relating to the field to which, in principle, the goods or services belong;
2. *Explanatory notes*: the explanatory notes explain which goods or services are meant or not meant to fall under the class headings and are to be considered an integral part of the classification;
3. *The alphabetical list*: the alphabetical list shows how individual goods or services are appropriate to a class;
4. *General remarks*: the general remarks explain what criteria should be applied if a term cannot be classified in accordance with the class headings or alphabetical list.

More information regarding the Nice Classification can be found on the website of the World Intellectual Property Organization (WIPO) at <http://www.wipo.int>.

3 Administrative Tools for Classification Purposes

When filing an electronic application through e-filing, users can select pre-approved terms to build their list of goods & services. All those selectable terms originate from a harmonised database and will automatically be accepted for classification purposes. Using these pre-approved terms will facilitate a smoother trade mark registration process. The harmonised database brings together terms which are accepted for classification purposes in all EU offices.

Should the applicant use a list of goods & services containing terms that are not found in the harmonised database, the Office will verify through an examination procedure whether they can be accepted.

Before filing an application the content of the harmonised database can be searched through the Office's tool TMclass (<http://tmclass.tmdn.org/ec2/>). This tool brings together classification databases of participating offices within and outside the EU and shows whether a term can be accepted by the office concerned. Within TMclass goods and services are grouped according to shared characteristics from a market perspective, starting from the more general and ending with the more specific. In this way, the user is provided with a simplified search, and is given a better overview of the content of each class, thus facilitating the selection of appropriate terms.

This grouping and ranking, also called Taxonomy, has no legal effect. In particular, the scope of protection of a Community trade mark is always defined by the natural and usual meaning of the chosen terms, not by the position of the terms in the Office's classification tools.

4 Building a List of Goods and Services

4.1 Clarity and precision

4.1.1 General principles

The goods and services for which the protection of the trade mark is sought should be identified by the applicant with sufficient clarity and precision to enable the competent authorities and economic operators, on that basis alone, to determine the extent of the protection sought (judgment of 19/06/2012, C-307/10, 'IP Translator', para. 49).

A description of goods and services is sufficiently clear and precise when its scope of protection can be understood from its natural and usual meaning. If this scope of protection cannot be understood, sufficient clarity and precision may be achieved by identifying factors such as characteristics, purpose and/or identifiable market sector. Elements that could help to identify the market sector¹ may be, but are not limited to, the following:

- consumers and/or sales channels
- skills and know-how to be used/produced
- technical capabilities to be used/produced.

A term may be part of the description of goods and services in a number of classes; it may be clear and precise in a particular class without further specification. For example: furniture (Class 20), clothing (Class 25), gloves (Class 25).

If protection is sought for a specialised category of goods and services or a specialised market sector belonging to a different class, further specification of the term may be necessary. For example: **furniture** especially made for medical purposes (Class 10), **furniture** especially made for laboratories (Class 9), protective **clothing** (Class 9) **clothing** especially for operating rooms (Class 10), **clothing** for pets (Class 18), gardening **gloves** (Class 21), baseball **gloves** (Class 28).

Tools such as TMclass (<http://tmclass.tmdn.org/ec2/>) are available to determine whether the particular category of goods and services needs this further specification or not.

4.1.2 Use of expressions (e.g. 'namely', 'in particular') to determine the scope of the list of goods/services

The use of the words 'namely' or 'being' is acceptable, but must be understood to be a restriction to the specific goods and services which are listed thereafter. For example, *pharmaceutical preparations, namely analgesics* in Class 5 means that the application only covers analgesics and not any other type of pharmaceuticals.

The expression 'in particular' can also be accepted as it serves to indicate an example of the goods and services which are applied for. For example, *pharmaceutical*

¹ Market sector describes a set of businesses that are buying and selling such similar goods and services that they are in direct competition with each other.

preparations, in particular analgesics means that the application covers any kind of pharmaceuticals, with *analgesics* being an example.

The same interpretation applies to the use of the terms ‘including’, ‘including (but not limited to)’, ‘especially’ or ‘mainly’ as in the example *pharmaceutical preparations, including analgesics*.

A term that would normally be considered unclear or imprecise can be made acceptable provided that it is further specified, e.g. by using ‘namely’ and a list of acceptable terms. An example would be *electrical apparatus, namely computers* for goods in Class 9.

Further examples of acceptable use

Class 29: <i>Dairy products namely cheese and butter</i>	This would restrict the goods to only cheese and butter and exclude all other dairy products.
Class 41: <i>Provision of sports facilities, all being outdoors.</i>	This would restrict the services to cover only outdoor facilities and exclude any indoor facilities.
Class 25: <i>Clothing, all being underwear</i>	This would restrict the goods covered to only that which is considered underwear and will exclude all other types of clothing.

Other words or phrases may only point out that certain goods are important, and the inclusion of the term does not restrict the further listing in any way. Examples include:

Class 29: <i>Dairy products, in particular cheese and butter</i>	The coverage would include all dairy products; cheese and butter are probably the TM owner’s most successful goods.
Class 41: <i>Provision of sports facilities, for example outdoor running tracks.</i>	The coverage now merely gives an example of one of several possibilities.
Class 25: <i>Clothing, including underwear</i>	The coverage extends to all clothing and not just underwear.

4.1.3 Use of the term ‘and/or’

The use of oblique strokes is acceptable in lists of goods and services; the most common use is in the phrase ‘and/or’, meaning that both goods/services referred to fall in the same class. For example:

- *Chemical/biochemical products*
- *Chemical and/or biochemical products*
- *Chemicals for use in industry/science*
- *Chemicals for use in industry and/or science*
- *Import/export agency services.*

4.1.4 Punctuation

The use of correct punctuation is very important in a list of goods and services, almost as important as the words.

The use of commas serves to separate items within a similar category or expression. For example, *flour and preparations made from cereals, bread, pastry and confectionery* in Class 30 must be read as that the goods can be or are made from any of those materials.

The use of a semi-colon means a separation between expressions. For example, *flour and preparations made from cereals, bread, pastry and confectionery, ices; honey, treacle; yeast, baking-powder* in Class 30 must be interpreted that the terms *honey and treacle* are independent from the other terms and do not form part of *preparations made from ...*

The separation of terms with incorrect punctuation can lead to changes in meaning and incorrect classification.

Take the example of *computer software for use with textile machinery; agricultural machines* in Class 9. In this list of goods and services the inclusion of a semi-colon means that the term *agricultural machines* must be considered as an independent category of goods. However, these are proper to Class 7, regardless of whether the intention was to protect computer software to be used in the field of textile machinery and agricultural machines.

A further example would be *retail services in relation to clothing; footwear; headgear* in Class 35. The use of a semi-colon renders the terms *footwear* and *headgear* as goods, which are separate and not included in the retail services. In such cases, the terms should be separated by commas.

4.1.5 Inclusion of abbreviations and acronyms in lists of goods and services

Abbreviations within lists of goods and services should be accepted with caution. Trade marks could have an indefinite life, and the interpretation of an abbreviation could vary over time. However, provided that an abbreviation has only one meaning in relation to the class of goods or services applied for, it can be allowed. The very well-known examples *CD-ROMs* and *DVDs* are acceptable in Class 9. If the abbreviation is well known in the field of activity it will be acceptable, but a more practical solution would be for examiners to initially carry out an internet search for the abbreviation to determine whether it needs to be expanded into words or the abbreviation or acronym followed by the abbreviation in square brackets (following WIPO's example).

Example

Class 45 *Services offering advice on the application and registration of CTMs.*

This could be expanded to:

Class 45 *Services offering advice on the application and registration of Community Trade Marks;*

or

Class 45 *Services offering advice on the application and registration of CTMs [Community Trade marks];*

Acronyms can be accepted in a list of goods or services as long as they are comprehensible and appropriate to the class applied for.

4.2 Terms and expressions lacking clarity and precision

4.2.1 General indications of the class headings of the Nice Classification which are deemed not to be sufficiently clear and precise

In collaboration with the Trade Mark Offices of the European Union, other (inter)national organisations, offices and various user associations, the Office has established a list of general indications of the class headings of the Nice Classification which are deemed not to be sufficiently clear and precise in accordance with the judgment of 19/06/2012, C-307/10, 'IP Translator'.

The 197 general indications of the Nice class headings were examined with respect to the requisites of clarity and precision. Of these, 11 were considered to lack the clarity and precision to specify the scope of protection that they would give, and consequently cannot be accepted without further specification. These are set out below in bold.

- Class 6 **Goods of common metal not included in other classes**
- Class 7 **Machines** and machine tools
- Class 14 Precious metals and their alloys and **goods in precious metals or coated therewith**, not included in other classes
- Class 16 Paper, cardboard and **goods made from these materials [paper and cardboard]**, not included in other classes
- Class 17 Rubber, gutta-percha, gum, asbestos, mica and **goods made from these materials [rubber, gutta-percha, gum, asbestos and mica]** and not included in other classes
- Class 18 Leather and imitations of leather, and **goods made of these materials [leather and imitations of leather]** and not included in other classes
- Class 20 **Goods (not included in other classes) of wood, cork, reed, cane, wicker, horn, bone, ivory, whalebone, shell, amber, mother-of-pearl, meerschaum and substitutes for all these materials, or of plastics**
- Class 37 **Repair**
- Class 37 **Installation services**
- Class 40 **Treatment of materials**
- Class 45 **Personal and social services rendered by others to meet the needs of individuals**

The remaining 186 Nice class heading terms comply with the requisites of clarity and precision and are therefore acceptable for classification purposes.

The reasons why each of the 11 Nice class heading terms were not found clear and precise are described below.

- Class 6 **Goods of common metal not included in other classes**
In light of the need for clarity and precision, this term does not provide a clear indication of what goods are covered as it simply states what the goods are made of, and not what the goods are. It covers a wide range of goods that may have very different characteristics and/or purposes, that may require very different levels of technical capabilities and know-how to

be produced and/or used, could target different consumers, be sold through different sales channels, and therefore relate to different market sectors.

Class 7 **Machines** and machine tools

In light of the need for clarity and precision, the term *machines* does not provide a clear indication of what machines are covered. Machines can have different characteristics or different purposes, they may require very different levels of technical capabilities and know-how to be produced and/or used, could target different consumers, be sold through different sales channels, and therefore relate to different market sectors.

Class 14 Precious metals and their alloys and **goods in precious metals or coated therewith, not included in other classes**

In light of the need for clarity and precision, the term *goods in precious metals or coated therewith, not included in other classes* does not provide a clear indication of what goods are covered, as it simply states what the goods are made of or coated with, and not what the goods are. It covers a wide range of goods that may have very different characteristics, that may require very different levels of technical capabilities and know-how to be produced, could target different consumers, be sold through different sales channels, and therefore relate to different market sectors.

Class 16 Paper, cardboard and **goods made from these materials, not included in other classes**

In light of the need for clarity and precision, the term *goods made from these materials [paper and cardboard], not included in other classes* does not provide a clear indication of what goods are covered, as it simply states what the goods are made of, and not what the goods are. It covers a wide range of goods that may have very different characteristics and/or purposes, that may require very different levels of technical capabilities and know-how to be produced and/or used, could target different consumers, be sold through different sales channels, and therefore relate to different market sectors.

Class 17 Rubber, gutta-percha, gum, asbestos, mica and **goods made from these materials and not included in other classes**

In light of the need for clarity and precision, the term *goods made from these materials [rubber, gutta-percha, gum, asbestos and mica] and not included in other classes* does not provide a clear indication of what goods are covered as it simply states what the goods are made of, and not what the goods are. It covers a wide range of goods that may have very different characteristics and/or purposes, that may require very different levels of technical capabilities and know-how to be produced and/or used, could target different consumers, be sold through different sales channels, and therefore relate to different market sectors.

Class 18 Leather and imitations of leather, and **goods made of these materials and not included in other classes**

In light of the need for clarity and precision, the term *goods made of these materials [leather and imitations of leather] and not included in other classes* does not provide a clear indication of what goods are covered, as it simply states what the goods are made of, and not what the goods are. It covers a wide range of goods that may have very different characteristics

and/or purposes, that may require very different levels of technical capabilities and know-how to be produced and/or used, could target different consumers, be sold through different sales channels, and therefore relate to different market sectors.

Class 20 Goods (not included in other classes) of wood, cork, reed, cane, wicker, horn, bone, ivory, whalebone, shell, amber, mother-of-pearl, meerschaum and substitutes for all these materials, or of plastics

In light of the need for clarity and precision, this term does not provide a clear indication of what goods are covered as it simply states what the goods are made of, and not what the goods are. It covers a wide range of goods that may have very different characteristics and/or purposes, that may require very different levels of technical capabilities and know-how to be produced and/or used, that could target different consumers, be sold through different sales channels, and therefore relate to different market sectors.

Class 37 Repair

In light of the need for clarity and precision, this term does not provide a clear indication of the services being provided, as it simply states that these are repair services, and not what is to be repaired. As the goods to be repaired may have different characteristics, the repair services will be carried out by service providers with different levels of technical capabilities and know-how, and may relate to different market sectors.

Class 37 Installation services

In light of the need for clarity and precision, this term does not provide a clear indication of the services being provided, as it simply states that these are installation services, and not what is to be installed. As the goods to be installed may have different characteristics, the installation services will be carried out by service providers with different levels of technical capabilities and know-how, and may relate to different market sectors.

Class 40 Treatment of materials

In light of the need for clarity and precision, this term does not give a clear indication of the services being provided. The nature of the treatment is unclear, as are the materials to be treated. These services cover a wide range of activities performed by different service providers on materials of different characteristics requiring very different levels of technical capabilities and know-how, and may relate to different market sectors.

Class 45 Personal and social services rendered by others to meet the needs of individuals

In light of the need for clarity and precision, this term does not give a clear indication of the services being provided. These services cover a wide range of activities performed by different service providers requiring very different levels of skill and know-how, and may relate to different market sectors.

CTM applications including one of the abovementioned eleven general indications will be objected to as being too vague. The applicant will be asked to specify the vague term.

The above non-acceptable general indications can become clear and precise if the applicant follows the principles set out before under paragraph 4.1 Principles of clarity and precision. The following is a non-exhaustive list of acceptable specifications.

Not a clear and precise term	Example of a clear and precise term
Goods of common metal not included in other classes (Class 6)	Construction elements of metal (Class 6) Building materials of metal (Class 6)
Machines (Class 7)	Agricultural machines (Class 7) Machines for processing plastics (Class 7) Milking machines (Class 7)
Goods in precious metals or coated therewith (Class 14)	Works of art of precious metal (Class 14)
Goods made from paper and cardboard (Class 16)	Filtering materials of paper (Class 16)
Goods made from rubber, gutta-percha, gum, asbestos and mica (Class 17)	Rings of rubber (Class 17)
Goods made of these materials [leather and imitations of leather] (Class 18)	Briefcases [leather goods] (Class 18)
Goods (not included in other classes) of wood, cork, reed, cane, wicker, horn, bone, ivory, whalebone, shell, amber, mother-of-pearl, meerschaum and substitutes for all these materials, or of plastics (Class 20)	Door fittings, made of plastics (Class 20) Figurines of wood (Class 20)
Repair (Class 37)	Shoe repair (Class 37) Repair of computer hardware (Class 37)
Installation services (Class 37)	Installation of doors and windows (Class 37) Installation of burglar alarms (Class 37)
Treatment of materials (Class 40)	Treatment of toxic waste (Class 40) Air purification (Class 40)
Personal and social services rendered by others to meet the needs of individuals (Class 45)	Personal background investigations (Class 45) Personal shopping for others (Class 45) Adoption agency services (Class 45)

Note that vague terms would not be made specific, or acceptable, by the addition of such terms as *including* or in *particular*. The example *machines, including milking machines* would not be acceptable as it remains vague. (see paragraph 4.1.2)

4.2.2 Vague terms

The same principles regarding clarity and precision as described above are applicable to all the goods and services listed in the application. Terms which do not provide a clear indication of the goods covered, should be objected to. Examples of such expressions are:

- *Electric/electronic apparatus/instruments*
- *Association services*
- *Facilities management services.*

They all must be specified as described above, i.e. by identifying factors such as characteristics, purpose and/or identifiable market sector.

4.2.3 The claim for all goods/services in this class or all goods/services of the alphabetical list in this class

If the applicant intends to protect all goods or services included in the alphabetical list of a particular class, it has to expressly indicate this by listing these goods or services explicitly and individually. In order to assist applicants, the use of the hierarchical structure (see paragraph 3 Administrative tools for classification purposes) is encouraged.

Applications are sometimes submitted for *all goods in Class X, all services in Class X, all goods/services in this class* or *all goods/services of the alphabetical list in this class* (or the like). This specification does not comply with Article 26(1)(c) CTMR which requires a list of the goods or services in respect of which the registration is requested. Consequently, no filing date is awarded.

On other occasions the applicant has correctly listed some goods and/or services to be covered and added, at the end of the listing in each class, the expression *and all other goods/services in this class* or *and all goods/services of the alphabetical list in this class* (or the like). In those cases, the application may proceed only for the part of the goods and/or services that is correctly listed. The Office will inform the applicant that those statements are not acceptable for classification purposes and thus will be deleted.

4.2.4 Reference to other classes within the list

References to other class numbers within a class are not acceptable for classification purposes. For example, the descriptions (in Class 39) *transport services of all goods in Classes 32 and 33* or (in Class 9) *computer software in the field of services in Classes 41 and 45* are not acceptable as in both cases the terms are considered to be unclear and imprecise and lack legal certainty as to what goods and services are covered. The only way to overcome the objection to these lists of goods and services will be for the respective goods of Classes 32 and 33, and the services of Classes 41 and 45 to be specified.

The term *...goods not included in other classes...* is not acceptable in service classes because this expression only has a sense in its original goods class.

For example, the heading of Class 22 reads *ropes, string, nets, tents, awnings, tarpaulins, sails, sacks and bags (not included in other classes)*. In that context the reference to *... not included in other classes* is meaningful. However, if that same term is used in a service class list of goods and services it cannot make sense. For example, *transport services of ropes, string, nets, tents, awnings, tarpaulins, sails, sacks and bags (not included in other classes)* in Class 39 could not be accepted. The mention of *... (not included in other classes)* must be deleted.

4.2.5 Trade marks in a list of goods/services

Trade marks cannot appear within a list of goods and services as if they were a generic term or a category of goods. In such cases, the Office will object to the inclusion of the term, and request its replacement by a generic term for the goods or services.

Example

Class 9: *Electronic devices for transmission of sound and images; video players; CD players; iPods.*

Since iPod™ is a trade mark, the applicant will be requested to replace it by a synonym such as *a small portable digital audio player for storing data in a variety of formats including MP3.*

Other examples are Caterpillar™ (the correct classification would be *crawler type vehicle*), Discman™ (*portable compact disc player*), Band-Aid™ (*sticking plasters*), Blu Ray discs™ (*optical storage discs*) or Teflon™ (*non-stick coating based on polytetrafluoroethylene*). This list is not exhaustive and in cases of doubt examiners should refer cases to a relevant expert within the Office.

4.2.6 Inclusion of the terms *parts and fittings; components and accessories* in lists of goods and services

The terms *parts and fittings; components and accessories* are, on their own or in combination with each other, neither clear nor precise enough for classification purposes. Each of the terms requires further qualification to become acceptable in its proper class. Such terms would become acceptable by identifying factors such as characteristics, purpose and/or identifiable market sector. For example:

- *Parts and fittings for motor vehicles* is acceptable in Class 12
- *Building components made of wood* is acceptable in Class 19
- *Musical accessories* is acceptable in Class 15.

4.2.7 Use of indefinite qualifiers

The use of qualifiers such as: 'the like'; 'ancillary', 'associated goods'; 'and related goods' and 'etc.' in a list of goods or services is unacceptable, since they do not comply with the requirements of clarity and precision (see paragraph 4.1).

5 Procedure of Examination

5.1 Parallel applications

While the Office will always strive for consistency, the fact that a list of goods and services has been previously accepted, but which is wrongly classified, does not have to lead to the acceptance of the same list in any subsequent applications.

5.2 Objections

Where the Office considers that there is a need to amend the list of goods and services it should, if possible, discuss the issue with the applicant. Whenever reasonably possible the examiner should offer a proposal for a correct classification. If the applicant submits a long list of goods/services which is not grouped under class

numbers or classified at all, then the examiner should simply object under Rule 2, and ask the applicant to provide the list in a form that complies.

The response from the applicant must, under no circumstances, extend the scope or range of goods or services (Article 43(2) CTMR).

Where the applicant has failed to identify any classes, or has incorrectly identified the class(es) for the goods or services, then any further explanation of the scope of the application may extend the number of classes required to accommodate the list of goods and services. It does not automatically follow that the list itself has been extended.

Example

An application covering *beer, wine and tea* in Class 33 should be corrected to:

Class 30: *Tea*.

Class 32: *Beer*.

Class 33: *Wine*.

Although there are now three classes covering the goods, the list of goods has not been extended.

When the applicant has correctly attributed a class number to a particular term, this limits the goods to those falling under that class. For example, an application for *tea* in Class 30 may not be amended to *medicinal tea* in Class 5 as that would extend the goods beyond those applied for.

Where there is a need to amend the classification, the Office will send a reasoned communication pointing out the error(s) detected in relation to the list of goods and services. The applicant will be requested to amend and/or to specify the list and the Office may propose the way in which the items should be classified.

The original time limit allowed to submit observations on the classification deficiency letter can only be extended once. No further extensions will be granted unless exceptional circumstances apply.

The Office will send a letter informing the applicant of the definitive agreed list of accepted terms.

5.3 Amendments

See also the Guidelines, Part E, Register Operations, Section 1, Changes in a Registration.

Article 43(1) and (2) CTMR allows for the amendment of an application. This includes the amendment of the list of goods and services provided that 'such a correction does not substantially change the trade mark or extend the list of goods and services'.

The amendment can be listed in either positive or negative terms, the following examples are both acceptable:

- *Alcoholic beverages all being whisky and gin.*
- *Alcoholic beverages none being whisky or gin.*

Since an amendment cannot extend the list of goods and services, it must be in the nature of a restriction or deletion of some of the terms originally contained in the application. Once such amendments (deletions) have been received (and later accepted) by the Office, the deleted terms cannot be re-introduced, nor can the remaining list of goods and services be extended.

A restriction should respect certain criteria:

1. The applicant cannot exclude goods and services that are not covered in the application and/or not covered by the relevant class.

For example the following would **not** be acceptable:

Class 32: *Syrups (original application) to syrups with the exception of fruit juices.*

Class 3: *Cosmetics with the exception of disinfecting substances (Class 5).*

2. The restriction must be **comprehensible** and give a sufficiently clear and precise (see also paragraph 4.2) indication of the goods or services to be excluded in the list or a sufficiently clear and precise indication of those goods and services which remain after the restriction.

For example the following would **not** be acceptable:

Class 16: *Typewriters, only related to financial services.*

3. The restriction must not contain references to trade marks.

For example the following would **not** be acceptable:

Class 9: *Apparatus for the reproduction of sound, namely iPods.*

4. The restriction must not contain a territorial limitation which contradicts the unitary nature of the CTM.

For example the following would **not** be acceptable:

Class 7: *Washing machines, only for sale in France.*

A restriction may result in a longer list of goods and services than that filed. For example, the original list of goods and services may have been filed as *alcoholic beverages*, but it could be restricted to *alcoholic beverages being wines and spirits, but not including whisky or gin and not including liqueurs, cocktails or combinations of beverages containing elements of whisky or gin.*

5.4 Addition of classes

Under the provisions of Article 43(2) CMTR (listed above), it is possible to add a class or classes to an application, but only where the goods or services detailed in the original application were clearly included in the wrong class or when a good or service has been clarified and needs to be classified in new class(es).

For example, assume the original list of goods reads:

Class 33: *Alcoholic beverages including beer, wines and spirits.*

Since *beer* is proper to Class 32, the applicant will be requested to transfer the term to Class 32, even if Class 32 was not listed in the original application. If the applicant agrees then the application will cover goods in Classes 32 and 33.

When classes are added, additional fees may be payable and the applicant must be informed accordingly.

6 Annex 1

Table of Contents

Introduction.....	19
Advertising services.....	19
Air freshening and perfuming preparations.....	19
Amusement apparatus and electronic games	19
Association services or services provided by an association to its members	20
Beauty apparatus.....	20
Bringing together of services	20
Broadcasting and/or transmission services	20
Brokerage services.....	21
Cases (and carrying bags)	21
Charitable services	21
Collection and storage services	22
Computer games and computer games apparatus	22
Curtains and blinds	23
Custom manufacture/manufacturing for third parties.....	23
Data services.....	23
Design services	24
Digital imaging services.....	24
Downloadable goods.....	24
Electricity and energy.....	24
Electronic and electric apparatus.....	25
Electronic cigarettes.....	25
Franchising	25
GPS systems – location, tracking and navigating.....	26
Hair styling	27
Hire services	27
Humanitarian aid services.....	27
Internet services, on-line services.....	27
Kits and sets	28
Leasing.....	29
Mail order	29
Manuals (for computers, etc.)	29
Manufacturing services	30
News services	30
On-line services	30
Ordering of services	30
Perfuming and air freshening preparations	31

Personal and social services rendered by others to meet the needs of individuals.....	31
Precious metal goods.....	31
Protective clothing.....	32
Rental services	32
Retail and wholesale services	33
Satellite tracking	35
Sets.....	35
Social networking services	35
Software publishing.....	35
Solar power	35
Storage services	36
Supply of	36
Systems.....	36
Tickets (for travel, entertainment etc.)	36
Video games	37
Virtual environment.....	37

Introduction

When classifying the general principles of the Nice Classification must be applied.

The purpose of this Annex is to clarify the classification of certain problematic terms. It also provides notes on classification practice (including words or phrases that should not be used).

The Office's classification database TMclass is available at <http://tmclass.tmdn.org>

Advertising services

In principle, advertising services belong to Class 35. The main entries on advertising services in the list of services in the Nice Classification are:

- *Advertising*
- *Radio advertising*
- *Radio commercials*
- *Television advertising*
- *Television commercials*
- *Layout services for advertising purposes*
- *Publication of publicity texts*
- *Production of advertising films.*

These entries cover the design of advertising material and production of commercials, as they are services which will be provided by advertising agencies.

Air freshening and perfuming preparations

See *perfuming and air freshening preparations*.

Amusement apparatus and electronic games

Following changes to the Nice Classification on 1 January 2012 (10th edition), all *games* (whether electronic or not) are classified in Class 28.

These are shown in the alphabetical list as follows:

- *Games (Apparatus for-)*
- *Video game machines*
- *Arcade video game machines.*

Most of these Class 28 devices come loaded with the games. However, if these games are not loaded on the devices, they will be recorded on data carriers or they will be downloadable. In these cases, the games are considered to be game programmes which are especially adapted for use with gaming devices and thus will be classified in Class 9.

See also *computer games*.

Association services or services provided by an association to its members

These, and similar terms are too vague to be acceptable. The type, or scope, of the service being provided needs to be mentioned. Examples of **acceptable** specifications are:

Class 35: *Association services in the nature of business administration services.*

Class 45: *Services provided by an association to its members in the form of legal services.*

See also *charitable services*.

Beauty apparatus

Class 7: *Sprayers (machines) for applying artificial sun tanning preparations.*

Class 8: *Hand-operated instruments/tools for beauty purposes
Tattooing needles/apparatus
Depilatory apparatus (electric and non-electric).*

Class 10: *Massage apparatus
Microdermabrasion apparatus
Apparatus for the treatment of cellulite
Lasers for cosmetic beauty treatments
Laser hair removal apparatus
Photoepilation apparatus.*

Photoepilation is a procedure carried out by pulsed light devices. These devices use the same principle as lasers (i.e. heating up the hair follicle), yet they are not lasers.

Class 11: *Ultra-violet ray lamps for cosmetic purposes
Sun beds
Steam apparatus for cleaning the skin.*

Class 21: *Cosmetic brushes and applicators.*

Bringing together of services

See *ordering of services* and *retail and wholesale services*.

Broadcasting and/or transmission services

These services are proper to Class 38; both mean the same thing. The services provided in this area only cover the provision of the means of communication (e.g. the provision of a network of fibre optic cables; the provision of broadcasts or

transmissions via geo-stationary satellite transmission facilities, the rental of communications apparatus and systems). Class 38 does **not** cover any programmes, advertising, information or advice which may be transmitted by means of telecommunications or broadcasting technology. Those services would remain in the appropriate classes.

Brokerage services

These are services provided by an individual or company whereby they buy and sell commodities for a fee or commission. The fee may be charged to the buyer or the seller of the commodity (or both). The broker may never see the goods or services in question.

There are three listed classes for brokerage services. These are:

Class 35: *Brokerage of name and address based lists.*

Class 36: *[A large number of listings for] brokerage of futures, carbon offsets, real estate, bonds, securities and other financial based items.*

Class 39: *Brokerage services relating to distribution, transport, and storage.*

Cases (and carrying bags)

Cases (and bags) adapted to carry or transport the product they are intended to contain are in principle, classified in the same class as the product they are adapted to carry. For instance *laptops bags* are proper to Class 9.

All non-adapted carrying bags are in Class 18.

Charitable services

This term is too vague to be accepted in any class without further qualification.

Charitable services are defined by the service which is being offered. Therefore, they can be classified in any of the service classes, given the correct definition. For example:

Class 35: *Charitable services, namely administration and general office work.*

Class 36: *The organisation of charitable collections; charitable fund raising.*

Class 38: *Telecommunications services for charitable purposes.*

Class 39: *Charitable services, namely ambulance transport.*

Class 40: *Charitable services, namely water treatment services.*

Class 41: *Charitable services, namely education and training.*

Class 42: *Charitable services, namely environmental protection services.*

Class 43: *Charitable services, namely providing food and drink and temporary accommodation.*

Class 44: *Charitable services, namely providing medical services.*

Class 45: *Charitable services, namely mentoring [personal or spiritual].*

Collection and storage services

In the case of physical goods, both collection and storage services would be proper to Class 39. This class includes *transport* and *warehousing* in its listings. This would also include the collection and physical storage of data, whether in written form or recorded on media (the Nice Classification has *physical storage of electronically stored data or documents* in Class 39).

Office services of electronically collecting, collating and manipulating data are all proper to Class 35.

Storage of digital data and *electronic data storage* are seen to be in analogy with hosting services, and so are proper to Class 42. *Cloud computing data storage services* are also proper to Class 42.

Computer games and computer games apparatus

The terms *computer games* and *video games* are highly similar and are treated as the same way.

The dictionary reference for computer games is as follows:

- 1 **(Noun)** 'any of various games, recorded on cassette or disc for use in a home computer, that are played by manipulating a mouse, joystick, or the keys on the keyboard of a computer in response to the graphics on the screen' (*Collins English Dictionary*).

The terms *computer games* / *video games*, as such, are therefore only acceptable in Class 9. The dictionary reference of the term clearly states that it must be a game, thus software. The terms can therefore be accepted in Class 9 without any further clarification.

Games which are acceptable in Class 28 come loaded with the games software. For example, the following terms can all be accepted in Class 28:

- *Arcade games*
- *Arcade video machines*
- *Computer game consoles*
- *Games (apparatus for)*
- *Hand held computer game devices*
- *Video game machines.*

Curtains and blinds

Blinds, in all their forms, can be used on windows both internally and externally. The classification of these goods depends upon the purpose of the product and its material composition.

Curtains are normally found in use indoors and they are similarly classified according to their material composition.

Examples of acceptable entries are:

Class 6: *Outdoor blinds of metal*
External metal blinds as part of a building for security purposes.

Class 17: *Curtains of asbestos (safety-)* (The material and purpose determine the classification).

Class 19: *Blinds [outdoor] not of metal and not of textile.* (These goods are probably made of wood).

Class 20: *Blinds (slatted indoor)*
Venetian and vertical window blinds.
Indoor window blinds
Blinds (indoor window) [shades] [furniture]
Curtains (bamboo-)
Paper blinds
Curtains (bead-)[for decoration].

Class 24: *Outdoor blinds of textile.*

The vast majority of curtains will fall under Class 24 since most domestic curtains (sometimes referred to as 'drapes') are made of textiles or plastic.

Care should be taken with any references to curtain walling, or curtain walls. These refer to a type of construction technique relating to buildings and the associated goods are building materials and are proper to Class 6 (for metal goods) or Class 19 (for non-metallic goods).

Custom manufacture/manufacturing for third parties

See *manufacturing services*.

Data services

The term cannot be accepted on its own. It must be qualified.

The provision of data can be proper to several classes depending on the way in which the data is provided or the nature of the data being provided. In each case the exact nature of the service being offered will need to be stated, *the provision of data* is not

enough. The following are examples of acceptable terms and their relevant classification:

Class 44: *Provision of data (information) relating to the use of pharmaceuticals.*
(This would refer to the systemised provision of data which could only be interpreted by someone with specialised medical training.)

Class 45: *Provision and interpretation of data relating to animal tracking.*
(This would refer to services in relation to the relocation of a lost or stolen animal. If the data were for other purposes, then the classification would be proper to other classes e.g. Class 42 for measuring or scientific reasons.)

Design services

Design services are, as such, proper to Class 42.

Design of advertising and *design of brand names* are both proper to Class 35 as these are both part of advertising services.

Likewise *landscape design*, *floral design*, *turf design* and *planning [design] of gardens* are proper to Class 44 as these are horticultural services.

Digital imaging services

The term *digital imaging services* has been deleted from Class 41 in the 10th edition of the Nice Classification. Consequently, the term cannot be accepted in Class 41 without any specification. This is because digital imaging can be classified in more than one class depending on the field the service refers to, e.g. medical, information technology or photography.

Acceptable terms include:

- *Digital imaging (photo editing)* in Class 41
- *Medical imaging services* in Class 44
- *Digital imaging (IT services)* in Class 42.

Downloadable goods

All material which is downloadable is proper to Class 9. This includes publications, music, ring tones, pictures, photographs, films or film extracts. The result of the download is that the material is captured onto the drives or memory of a computer, telephone or PDA where it operates independently of the source from whence it came. These can also be called *virtual goods*. All these downloadable goods can be retailed.

Electricity and energy

The following is a guide to some of the goods and services which surround electricity.

Class 4: *Electrical energy.*

Class 7: *Electrical generators.*

Class 9: *Apparatus and instruments for conducting, switching, transforming, accumulating, regulating, or controlling electricity*
Solar cells for electricity generation
Photovoltaic cells and modules.

Class 36: *Brokerage of electricity (see also note under brokerage services).*

Class 39: *Distribution of electricity*
Storage of electricity.

Class 40: *Generation of electricity.*

See *solar power.*

Electronic and electric apparatus

The term *electronic and electric apparatus/devices/instruments* is too vague for classification purposes; it is not acceptable in any goods class, and should be specified.

Please be aware that specifications of *electronic and electric apparatus / devices / instruments* such as listed below are considered too vague as well:

- for controlling the environment
- for household purposes
- for use in hairdresser salons.

Electronic cigarettes

Electronic cigarettes, e-cigarettes or e-cigs are – for classification purposes – acceptable only in Class 34, even if they would serve a medical purpose. Non-electronic parts of these types of cigarettes, like cartridges, atomisers or (aroma) substances for these cigarettes are also classified in Class 34.

The electronic parts like batteries and a microcomputer controlled circuits for electronic cigarettes are not acceptable in these classes and belong – as usual – to Class 9.

Franchising

The verb ‘franchise’ refers to the giving or selling of a franchise to another party. As a noun ‘franchise’ means ‘the authorisation granted to an individual or group by a company to sell its products or services in a particular area’ (*Oxford English Dictionary*).

Without any further specification, the office will not accept the term *franchise service* or *franchising services* in Class 35. In order to be acceptable a clarification is required.

For example:

Class 35: *Business advice relating to franchising.*

Class 36: *Financing services relating to franchising.*

Class 45: *Legal services relating to franchising.*

GPS systems – location, tracking and navigating

GPS and satellite navigation systems (Class 9) provide location, tracking and navigating services, to provide the user with information.

The easiest way to classify these services is to divide them into those services which provide the telecommunications which run the services (Class 38) and those services which provide information via the GPS device. The range of information provided goes beyond mere travel route information (Class 39). It can include information regarding restaurants and accommodation (Class 43), information regarding shopping outlets (Class 35) or telephone numbers (Class 38).

The use of GPS devices in relation to the movement of vehicles and people can also lead to classifications over a range of classes. Route planning services (Class 39) have already been mentioned. This classification would also extend to logistic or freight moving companies keeping track of their vehicles using the same devices.

GPS systems can also be used in conjunction with other technology, to locate the source of a mobile telephone signal. If this is being done as part of a telecommunication service it will be proper to Class 38. If, however, it is being done as part of a criminal investigation service it would be proper to Class 45.

There are other services that can be associated with the services listed above. For example, the creation of maps for GPS systems is proper to Class 42. The downloadable applications which run the service or provide alternative 'voices' are proper to Class 9. The retail services for providing the downloadable applications are proper to Class 35.

The examples below demonstrate how these and other terms are classified.

Class 35: *Compilation and provision of commercial directory information regarding service providers for GPS navigation.*

Class 38: *Satellite transmissions*
Providing public subscribers directory information for GPS navigation
Providing access to general information supplied via satellite transmission
Telecommunications services for location and tracking of persons and objects
Tracking of mobile telephone via satellite signals
Location of mobile telephones via satellite signals
Providing access to GPS navigation services via satellite transmission
Satellite transmission of navigation data.

Class 39: *Providing GPS navigation services*
Providing traffic information services via satellite transmission
Providing road information services via satellite transmission
Location services for logistics purposes of vehicles and goods
Tracking services for logistics purposes of vehicles and goods.

Class 42: *Providing weather information via satellite transmission*
Creation of GPS maps.

Class 45: *Providing public amenity and civic directory information for GPS navigation*
Tracing and locating of missing persons via satellite transmission
Tracking of persons carrying electronic tagging devices
Security tracking services of vehicles
Security location services of vehicles.

Hair styling

Most *electric and non-electric hair styling apparatus* is classified in Class 8 (e.g. *electric hair curling irons; hair tongs [non-electric hand implements]; crimping irons for the hair* etc.). Except:

Class 26: *Electric hair curlers/rollers* (e.g. CARMEN™ CURLERS).

Class 26: *Hair curlers/rollers, other than hand implements.*

Class 11: *Hair dryers.*

Class 21: *Combs and brushes* (non-electric and electric).

Hire services

See *rental services*.

Humanitarian aid services

Office practice on *humanitarian aid services* is the same as that on *charitable services*; the nature of the services must be specified (see *charitable services*).

Internet services, on-line services

The term *internet services* is neither clear nor precise for acceptance in any class. It must be further defined.

There are a range of services, offered by individuals and business to other individuals and businesses, which relate to the setting up, operation and servicing of internet web-sites and these are covered by appropriate entries in a number of classes.

There is an even wider range of services offered to customers through the medium of telecommunications including via the internet. It is possible to shop over the internet,

obtain banking advice, learn a new language, or listen to a 'local' radio station which is situated on the other side of the world.

The application of the Nice Classification system generally applies regardless of whether the service is provided face-to-face, in dedicated premises, over a telephone, on-line from a database or from an internet web site.

Acceptable terms include:

Class 35: *Advertising services provided over the internet.*

Class 36: *On-line banking services.*

Class 38: *Internet provider services.*

Class 41: *On-line gaming services.*

Class 42: *Providing on-line support services for computer program users.*

Class 45: *On-line social networking services.*

Kits and sets

It is common in trade for certain goods to be sold in groups of more than one item. If the items are all the same, e.g. a pack of three toothbrushes, then the classification is simple. However, sometimes the collection of goods could be component parts of another item, or have a function which is not defined by the individual goods. These groups of goods sometimes have collective names such as kit or set. These small words can have a big impact on (1) the acceptability as collection of goods and (2) the appropriate classification.

A kit can mean either:

1. a set of parts ready to be made into something (for example: *a kit for a model plane*) or
2. a set of tools or equipment that is to be used for a particular purpose (for example: *a first-aid kit*).

A set is a number of articles that are thought of as a group. This may have a defined number or not (e.g. *a set of keys, a set of saucepans, a set of golf clubs; a cutlery set*).

Kits appear in the Nice Classification, for example, as in the following example:

Class 3: *Cosmetic kits.*

Class 5: *First aid kits* (seen as a collection of plasters and treatments).

It sometimes happens that the individual goods which make up the kit or set would normally be classified in more than one class. However, the Office will not object to acceptance of such collective terms, provided that they make sense and/or are in common usage.

When determining the correct classification for a kit or set, it is necessary to understand either; what the kit is going to be used for, or alternatively, if it going to make or construct something from its components, what the finished article will be.

Examples of acceptable terms would be:

Class 8: *Manicure and pedicure sets.*

Class 9: *Hands free kits for phones.*

Class 12: *Tyre repair kits* (for repairing a vehicle part that is in Class 12).

Class 27: *Rug making kit.*

Class 28: *Scale model kits [toys]*
Toy model kits.

Class 32: *Beer making kits.*

Class 33: *Wine making kits.*

Leasing

The general remarks in the Nice Classification (10th edition) say, 'Leasing services are analogous to rental services and therefore should be classified in the same way. However, hire- or lease-purchase financing is classified in Class 36 as a financial service.'

See also *rental services.*

Mail order

See *retail and wholesale services.*

Manuals (for computers, etc.)

Electronic items such as computers, printers, photocopiers and other electronic items are often delivered as new goods to the customer with a list of operating instructions. The instructions can be in paper (printed) format, or in an electronic format, such as a recording on a disc, or as a downloadable or non-downloadable document available at the manufacturer's web-site.

Examples of this would be:

Class 9: *Computer software and hardware and associated manuals **in electronic format** sold as unit therewith.*

Class 16: *Manuals sold as a unit with computer software and hardware.*

Manufacturing services

Manufacturing is only seen as a service when it is undertaken for third parties and must be specified as such. Custom manufacturing of certain single, 'one-off' products for third parties, for example a sailing boat or a sports car, by a specialist in that field would be proper to Class 40. Custom construction of e.g. made-to-measure kitchen units would be included in Class 40, but their installation would be proper to Class 37.

News services

News agency services are proper to Class 38. They are essentially a hub or collection point through which journalists and others can file and obtain newsworthy materials (in the form of stories, script or photographs). They do not perform any other function such as editing or verification services.

News reporting services are proper to Class 41. News has no boundaries, the subject could be anything.

Other examples include:

Class 38: *News broadcasting services.*

Class 40: *Printing of newspapers.*

Class 41: *Presentation of news (programmes)*
Publication of news
Editing of news.

As far as electronic news publications are concerned, *downloadable news pod casts, news clips, news items, news publications*, etc. are all goods which are proper to Class 9.

On-line services

See *internet services*.

Ordering of services

The ordering of goods/services for others can be accepted in Class 35 as a business service / office function. There are individuals and companies who offer services of providing solutions to a variety of problems on behalf of others, e.g. if you need a leaking tap to be fixed, the intermediary (service provider) will arrange the services of a plumber for you. This classification is in analogy with the Nice Classification entry *procurement of services for others [purchasing goods and services for other business]*.

Perfuming and air freshening preparations

There are preparations which serve to merely mask unpleasant smells (perfume) and there are also preparations which chemically 'wrap-up' and remove unpleasant odours (deodorisers) and their apparatus. They are properly classified as follows:

Class 3: *Air fragrancng preparations*
Incense
Potpourris [fragrances]
Sachets for perfuming linen
Scented wood
Fumigation preparations [perfumes]
Room sprays.

Class 5: *Air deodorising preparations*
Air purifying preparations

Class 11: *Air deodorising apparatus*

Other goods which may release pleasant odours include *perfumed candles* which are proper to Class 4 (the release of perfume is a secondary characteristic) and *perfumed drawer liners* (proper to Class 16 as being analogous to *packaging material* and usually made of paper).

Personal and social services rendered by others to meet the needs of individuals

The general indication *personal and social services rendered by others to meet the needs of individuals* is not clear and precise enough and will not be accepted by the Office (see also paragraph 4.2).

The wording needs to be specified by the applicant.

There are many personal and social services that are classifiable, but are proper to classes other than Class 45. These include:

Class 36: *Personal insurance services* (such as life assurance).

Class 41: *Personal tuition.*

Class 44: *Personal medical services.*

Class 45: *Personal body guarding*
Consultancy services relating to personal appearance
Personal tour guide services
Personal shopping services.

Precious metal goods

The general indication *goods of precious metals or coated therewith, not included in other classes* in Class 14 is not clear and precise enough and will not be accepted by

the Office (see also paragraph 4.2). The applicant needs to specify the wording of the term.

Caution needs to be applied when classifying goods made from precious metals.

Historically, virtually all goods which were made from, or coated with, precious metals were grouped together in Class 14. It was considered that the material had an influence on why the goods were bought, and that in turn determined where the goods were classified.

Since 1 January 2007, the classification of many goods that would have been in Class 14 has been re-classified. The reclassification of the goods is based upon their function, rather than the material from which they are made.

The following goods are examples of goods which are classified according to their function or purpose:

Class 8: *Cutlery of precious metal.*

Class 16: *Pen nibs of gold.*

Class 21: *Teapots of precious metal*

Class 34: *Cigarette and cigar boxes made of precious metals.*

Protective clothing

If items that are worn (or sometimes carried) have their **primary** function as the prevention of serious and/or permanent injury, or death or if that protection is offered against, for example contact with or exposure to extremes of temperature, chemicals, radiation, fire, or environmental or atmospheric hazards, then those goods would be proper to Class 9.

Examples of such protective goods would include hard-hats worn on building sites, and helmets worn by security guards, horse riders, motorcyclists, and American football players. Bullet-proof vests, metal toe-capped shoes, fireproof jackets and metal butchers' gloves are examples of these: they are not clothing as such. Aprons, smocks and overalls which merely protect against stains and dirt are not proper to Class 9 but to Class 25 as general clothing. Protective sporting articles (except helmets) are proper to Class 28: none of these protect against loss of life or limb.

Rental services

Rental or hire services are classified, in principle, in the same class as the services provided. For example, the rental of cars falls in Class 39 (transport), rental of telephones in Class 38 (telecommunications), rental of vending machines in Class 35 (retail services). The same principle applies to *leasing services* which are found on TMclass in all of the service classes.

Retail and wholesale services

A retail service is defined as 'The action or business of selling goods in relatively small quantities for use or consumption' (*Oxford English Dictionary*); this defines the scope of the services covered by this term.

There is an indication in the explanatory note to the listing of Class 35 in the Nice Classification that the term *the bringing together, for the benefit of others, of a variety of goods (excluding the transport thereof), enabling customers to conveniently view and purchase these goods* is acceptable in Class 35. *Retail services* are classified in analogy to this entry.

However, as regards *retail services* or similar services in Class 35 relating to the sale of goods, such as wholesale services, mail order services and e-commerce services, the Office applies judgment of 07/07/2005, C-418/02, 'Praktiker': the term *retail services* is only acceptable where the type of goods or services to be sold or brought together for the benefit of others, is indicated with sufficient clarity and precision (see paragraph 4.1). The term *retail services of a supermarket* and, by extension, *retail services of a department store* and similar terms are not acceptable as the goods to be sold are not defined.

The 10th edition of the Nice Classification (version 2013) includes *retail or wholesale services for pharmaceutical, veterinary and sanitary preparations and medical supplies*, which shows how terms can be expressed.

Examples of categories of goods which do not fulfil the requirements of clarity and precision:

- *Merchandising articles*
- *Fair-trade goods*
- *Lifestyle accessories*
- *Gift articles*
- *Souvenirs*
- *Collectors' articles*
- *Housewares.*

Retail services for non-acceptable general indications of the class headings (see paragraph 3.4.2) are not acceptable. For example, the Office will not accept *retail services for machines*. However, *retail services in relation to agricultural machines* would be sufficiently precise and acceptable.

As regards 'retail of services', (i.e. *services which consist of bringing together, for the benefit of others, of a variety of services, enabling consumers to conveniently compare and purchase those services*), the Court has held that these must also be formulated with sufficient clarity and precision so as to allow the competent authorities and other economic operators to know which services the applicant intends to bring together (see judgment of 10/07/2014, C-420/13 'Netto Marken-Discount').

This decision confirms that the 'bringing together of services' is an activity that is entitled to protection. The Court placed greater emphasis on the importance of defining the services being brought together, than on defining the action of 'bringing together' itself (thereby echoing its earlier judgment of 07/07/2005, C-418/02, 'Praktiker').

Terms expressing this should satisfy two requirements, firstly, using the familiar terms 'bringing together, for the benefit of others... enabling customers to compare and purchase...' in order to 'frame' the services being brought together and describe the actual retail activity itself, and secondly, in describing the services which are being brought together, employing terms which are understood and acceptable in their own right (e.g. legal services, broadcasting services, slimming club services etc.). In order to meet the fundamental requirements for clarity and precision as confirmed by IP Translator, any claim to the retailing or 'bringing together' of services must be worded in this manner.

The following are example specifications which will now be deemed acceptable:

The bringing together, for the benefit of others, of a variety of legal services, enabling customers to conveniently compare and purchase those services.

The bringing together, for the benefit of others, of slimming club services, video-on-demand services, and detective agency services, enabling customers to conveniently compare and purchase those services.

The bringing together, for the benefit of others, of a variety of broadcasting services, enabling customers to conveniently compare and purchase those services.

In the case of the bringing together of services, wordings including 'retail services connected with...', 'retail services connected with the sale of...' and 'electronic shopping retail services connected with...' do not provide a clear distinction between the retailing of services and the provision of those services in their own right.

The following examples will therefore not be accepted and will be subject to an objection:

Retail services connected with takeaway services.

Retail services connected with the sale of legal services.

Mail order retail services connected with the sale of detective agency services.

The CJEU's ruling is not to be interpreted as providing a means for obtaining duplicative protection of services intended to be provided in their own right (whether proper to Class 35 or elsewhere). Nor should it be perceived as an alternative means for providing protection for the advertising of one's own services. Thus, if an application covers 'the bringing together for the benefit of others of telecommunication services enabling customers to conveniently compare and purchase those services', these services do not cover the actual provision of telecommunication services (which belongs to Class 38), but only the bringing together of a variety of telecommunication service providers enabling consumers to conveniently compare and purchase those services.

Finally, the specification of the goods or services by terms such as 'including, in particular, for example, featuring, specifically, such as, is not precise enough since all these terms mean, in principle, 'for example'. They do not restrict the goods or services which follow. Consequently, the abovementioned terms should be replaced by 'namely or being' as it will restrict the goods or services which follow those terms.

Satellite tracking

See *GPS systems – location, tracking and navigating*.

Sets

See *kits and sets*.

Social networking services

Social networking services is an acceptable term in Class 45. It would be seen as a personal service which includes the identification and introduction of like-minded people for social purposes.

There are other aspects of the 'social networking' industry which could be proper to classes other than Class 45, for example:

Class 38: *The operation of chat room services*
The provision of on-line forums.

Software publishing

Software publishing belongs to Class 41. A software publisher is a publishing company in the software industry between the developer and the distributor. Publishing, according to its definition, includes *newspaper publishing* and *software publishing*.

Solar power

Solar power is energy that is derived from the sun and converted into heat or electricity.

Goods relating to the generation and storage of electricity from solar energy are classified in Class 9.

Goods relating to the generation and storage of heat from solar energy are classified in Class 11.

Services relating to the generation of electricity from solar energy are classified in Class 40.

Class 9: *Photovoltaic cells*
Solar panels, modules and cells.

Class 11: *Solar collectors for heating.*

Class 40: *Production of energy.*

See *electricity and energy*.

Storage services

See *collection and storage services*.

Supply of ...

Care should be taken in the acceptance of this term when it is used to qualify services. It is acceptable in some circumstances, for example, *supply of electricity* in Class 39, where the term is often closely allied to *distribution*. It is also acceptable in the term *catering services for the supply of meals* (in Class 43) because the material being supplied, and the nature of the service, have both been given.

In the term *supply of computer software* (in Class 42) it is not clear what services are being provided. Whilst this class does include the services of *design, rental, updating and maintaining computer software*, it is not clear if any of those services are included in the general term *supply*. The word is often used as an apparent synonym for retail services but Class 42 does not include such services, they would be proper to Class 35.

Systems

This is another term which can be too unclear or too imprecise to be accepted.

It can be accepted only when qualified in a way that has a clear and unambiguous meaning. For example, the following are acceptable:

Class 7: *Exhaust systems.*

Class 9: *Telecommunication systems*
Computer systems
Alarm systems.

Class 16: *Filing systems.*

Tickets (for travel, entertainment etc.)

A ticket is a 'promise to supply' in relation to a service, or a reservation service, the right to a service. Examples include:

Class 39: *Issuing of airplane tickets.*

Class 41: *Ticket agency services (box office).*

Note that tickets are not seen as goods retailed in Class 35.

Video games

See *computer games*.

Virtual environment

The term *providing a virtual environment* is neither clear nor precise enough as it can relate to different areas of activities and classes. The term must be further defined.

Acceptable terms include:

Class 38: *Providing a virtual chatroom*
Providing access to a virtual environment.

Class 42: *Hosting of a virtual environment*
Maintenance of a virtual environment.

***GUIDELINES FOR EXAMINATION IN THE
OFFICE FOR HARMONIZATION IN THE
INTERNAL MARKET (TRADE MARKS AND
DESIGNS) ON COMMUNITY TRADE MARKS***

PART B

EXAMINATION

SECTION 4

ABSOLUTE GROUNDS FOR REFUSAL

Table of Contents

2.7 Public policy or morality, Article 7(1)(f) CTMR	4
2.7.1 ‘Public policy’	4
2.7.1.1 Concept and categories.....	4
2.7.1.2 Plant Variety Denominations	5
2.7.2 Accepted principles of morality.....	7
2.8 Deceptiveness: Article 7(1)(g) CTMR.....	10
2.8.1 Examination of the deceptive character	10
2.8.2 Market reality and consumers’ habits and perceptions	12
2.8.3 Trade marks with geographical connotations relating to the location of the applicant or the place of origin of the goods/services	13
2.8.4 Trade marks making reference to an ‘official’ approval, status or recognition	13
2.8.5 Relation with other CTMR provisions	14
2.9 Protection of flags and other symbols – Articles 7(1)(h) and (i) CTMR. 16	16
2.9.1 Protection of armorial bearings, flags, other state emblems, official signs and hallmarks indicating control and warranty under Article 7(1)(h) CTMR – Article 6 <i>ter</i> (1)(a) and (2) PC	16
2.9.1.1 Examination of marks consisting of or containing a state flag.....	20
2.9.1.2 Examination of marks consisting of or containing armorial bearings and other state emblems.....	24
2.9.1.3 Examination of marks consisting of or containing official signs and hallmarks indicating control and warranty.....	27
2.9.2 Protection of armorial bearings, flags, other emblems, abbreviations and names of international intergovernmental organisations under Article 7(1)(h) CTMR – Article 6 <i>ter</i> (1)(b) and (c) PC	27
2.9.3 Protection of badges, emblems or escutcheons other than those covered by Article 6 <i>ter</i> of the Paris Convention under Article 7(1)(i) CTMR.....	34
2.10 Article 7(1)(j) CTMR.....	40
2.10.1 Introduction	40
2.10.2 The application of Article 7(1)(j) CTMR	42
2.10.2.1 Relevant PDOs/PGIs.....	42
2.10.2.2 Situations covered by Article 103 of Regulation (EU) No 1308/2013 and Article 16 of Regulation (EC) No 110/2008.....	43
2.10.2.3 Relevant goods	51
2.10.3 PDOs/PGIs not protected under Regulations (EC) No 1308/2013 and No 110/2008	53
2.10.3.1 PDOs/PGIs protected at national level in an EU Member State	53
2.10.3.2 PDOs/PGIs from third countries	53
2.11 Article 7(1)(k) CTMR.....	55
2.11.1 Introduction	55
2.11.2 The application of Article 7(1)(k) CTMR	57
2.11.2.1 Relevant PDOs/PGIs.....	57
2.11.2.2 Situations covered by Article 13(1) of Regulation (EU) No 1151/2012	58
2.11.2.3 Relevant goods	66
2.11.3 PDOs/PDIs not protected under Regulation (EU) No 1151/2012	69
2.11.3.1 PDOs/PDIs protected at national level in an EU Member State	69
2.11.3.2 PDOs/PDIs from third countries	70
2.12 Community collective marks.....	72
2.12.1 Character of collective marks	72

2.12.2	Ownership.....	73
2.12.3	Particularities as regards absolute grounds for refusal	74
2.12.3.1	Descriptive signs	74
2.12.3.2	Misleading character as to its nature.....	75
2.12.3.3	Regulations of use contrary to public policy and morality.....	75

2.7 Public policy or morality, Article 7(1)(f) CTMR

Article 7(1)(f) CTMR excludes from registration trade marks that are contrary to public policy or to accepted principles of morality. The rationale of Article 7(1)(f) CTMR is to preclude trade marks from registration where granting a monopoly would contravene the state of law or would be perceived by the relevant public as going directly against the basic moral norms of society.

The Office considers that ‘public policy’ and ‘accepted principles of morality’ are two different concepts, which often overlap.

The question whether the goods or services applied for can be legally offered in a particular Member State’s market is irrelevant for the question whether the sign itself falls foul of Article 7(1)(f) CTMR (judgment of 13/09/2005, T-140/02, ‘Intertops’, para. 33). Whether or not a mark is contrary to public policy or accepted principles of morality must be determined by the intrinsic qualities of the mark applied for and not by the circumstances relating to the conduct of the person applying for the trade mark (judgment of 13/09/2005, T-140/02, ‘Intertops’, para. 28). In its judgment of 20/09/2011, T-232/10, ‘Soviet Coat of Arms’, the General Court held that the concepts of ‘public policy’ and ‘acceptable principles of morality’ must be interpreted not only with reference to the circumstances common to all Member States but by taking into account ‘the particular circumstances of **individual Member States** which are likely to influence the perception of the relevant public within those States’ (para. 34).

The legislation and administrative practice of certain Member States can also be taken into account in this context (i.e. for assessing subjective values), not because of their normative value, but as evidence of facts which make it possible to assess the perception of the relevant public in those Member States (judgment of 20/09/2011, T-232/10, ‘Soviet Coat of Arms’, para. 57). In such a case, the illegality of the CTM applied for is not the determining factor for the application of Article 7(1)(f) CTMR but rather is of evidential value with regard to the perception of the relevant public in the Member State(s) in question.

Considering that the specific circumstances of **individual** Member States may not be widely known in the European territory, the objection letter should explain these circumstances clearly in order to make sure that the applicant is able to fully understand the reasoning behind the objection and is able to respond accordingly.

2.7.1 ‘Public policy’

2.7.1.1 Concept and categories

This objection derives from an assessment based on objective criteria. ‘Public policy’ refers to the body of Union law applicable in a certain area, as well as to the legal order and the state of law as defined by the Treaties and secondary EU legislation, which reflect a common understanding on certain basic principles and values, such as human rights. As indicated above, national legislation may also be taken into account, not because of its normative value, but as evidence of facts which make it possible to assess the perception of the relevant public in those Member States.

The following is a non-exhaustive list of examples of when signs will be caught by this prohibition.

1. On 27/12/2001 the Council of the European Union adopted Common Position 2001/931/CFSP on the application of specific measures to combat terrorism (OJ L 344, 28/12/2001, p. 93) later updated by Council Common Position 2009/64/CFSP (OJ L 23, 27/01/2009, p. 37 and available online at: <http://eur-lex.europa.eu/LexUriServ/LexUriServ.do?uri=OJ:L:2009:023:0025:0029:EN:PDF>) which contains a list of individuals and groups facilitating, attempting to commit or committing terrorist acts in EU territory. Any CTM applied for which can be deemed to support or benefit an individual or a group on that list will be rejected as being against public policy.
2. Use of the symbols and names of Nazi organisations is prohibited in Germany (§ 86a dt. StGB (German Criminal Code), [BGBl. Nr. 175/1998](#)) and in Austria (§ 1 öst. Abzeichengesetz (Austrian Law on Insignias), [BGBl. Nr. 84/1960](#) in conjunction with § 1 öst. Verbotsgesetz (Austrian Prohibition Law), [BGBl. Nr. 25/1947](#)). Any CTM applied for which uses such symbols or names will be rejected as being against public policy.
3. Bearing in mind that the notion of 'public policy' also covers specific EU legislation in force in a given field, and insofar as there is both an EU Regulation and an International Convention that is binding on the European Union preventing the granting of exclusive rights in the name of a plant variety registered in the European Union, it follows that it is contrary to European public policy to grant exclusive trade mark rights in the name of a plant variety registered in the European Union, which is, therefore, considered to be descriptive by law.

2.7.1.2 Plant Variety Denominations

Plant variety names describe cultivated varieties or subspecies of live plants or agricultural seeds. Council Regulation (EC) No 2100/94 on Community plant variety rights (CPVRR) establishes a system of Community plant variety rights (CPVR) as the sole and exclusive form of Community industrial property rights for plant varieties. A variety denomination must ensure clear and unambiguous identification of the variety and fulfil several criteria (Article 63 CPVRR). The applicant for a CPVR must give a suitable variety denomination that shall be used by anyone who markets such variety in the territory of a member of the International Union for the Protection of New Varieties of Plants (UPOV), even after the termination of the breeder's right (Article 17 CPVRR).

Since 2005, the European Union is party to the International Convention for the Protection of New Varieties of Plants (UPOV Convention), which has become an integral part of the Union's legal order. Under Article 20(1) UPOV Convention, the variety shall be designated by a denomination which will be its generic designation. Furthermore, each Contracting Party shall ensure that no rights in the designation registered as the denomination of the variety shall hamper the free use of the denomination in connection with the variety, even after the termination of the breeder's right.

Therefore, both the CPVRR and the UPOV Convention impose the obligation to use

the variety denominations in order to commercialize protected varieties or varieties whose protection has ended.

The use of variety denominations allows the interested person to know the variety it is using or purchasing and possibly the breeder and the origin of the variety. The obligation to use the variety denominations contributes to the regulation of the market and to the safety of transactions in the agricultural and food sector, avoiding potential misleading of the public and counterfeiting. It is therefore a matter of public interest and public safety to use the adequate variety denomination in respect of a variety.

According to Article 18(2) CPVRR, a third party may hamper the free use of a variety denomination only if the rights in respect of a designation that is identical with the variety denomination were granted before that variety denomination was designated pursuant to Article 63 CPVRR.

A contrario, Article 18(2) CPVRR implies that no exclusive rights should be granted in respect of a designation that is identical with the variety denomination, after such variety denomination has been designated pursuant to Article 63 CPVRR.

OHIM therefore considers that registration of a CTM that would hamper the free use of a variety denomination after the grant of a CPVR to the corresponding variety is contrary to public policy.

As a consequence, CTM applications consisting of or containing signs which, if registered, would lead to an undue monopolisation of a variety denomination designating a variety protected by a CPVR or a variety that is no longer protected by a CPVR, shall be objected to on the grounds of being contrary to public policy under Article 7(1)(f) CTMR, in relation to Article 18(2) CPVRR, which provides for the free use by third parties of the denomination of a plant variety in connection with the variety itself (i.e. descriptive use).

The Community Plant Variety Office (CPVO), based in Angers (France), is the European Union's agency responsible for implementing a system for the protection of plant variety rights.

The CPVO maintains a register of protected plant varieties. The protected varieties and the varieties whose CPVR was terminated can be searched, based on their variety denomination and/or other search criteria, through the CPVO Variety Finder¹, available in the Office's intranet, which should be consulted by examiners as a reference tool whenever the type of goods and/or services covered by the CTM application so dictate. In particular, whenever the specification of a CTM application refers to *live plants, agricultural seeds, fresh fruits, fresh vegetables* or equivalent wordings, the examiner must verify that the term or terms making up the trade mark do not coincide with a registered variety denomination or with the denomination of a variety for which protection has been surrendered, terminated or has expired. The examiner will check the CPVO database in order to ascertain whether the term or terms making up the CTM application coincide with a variety denomination already entered in the abovementioned CPVO register. The search should be confined to variety denominations registered for the European Union.

¹ <http://www.cpvo.europa.eu/main/en/home/databases/cpvo-variety-finder>.

If the check shows that the CTM applied for consists of or contains an identical reproduction of the variety denomination (be it in a word or in a figurative mark), the examiner must raise an objection under Article 7(1)(f) CTMR in respect of the relevant plant, seeds and fruits, as well as the dried, preserved and frozen fruits, since registration of a CTM consisting of a variety denomination entered in the abovementioned EU register is contrary to public policy. If, for example, a CTM applied for 'flowers' contains a VD for a kind of rose, the list of goods will have to be limited in order to exclude 'roses'. Moreover, if more than one VD appear in a CTM applied for – say, a VD for 'apples' and another one for 'strawberries' –, the list of goods will have to be limited in order to exclude the goods covered by each VD, i.e., apples and strawberries.

Finally, where a plant variety denomination is used in the market but has not been registered or published in the CPVO, or in case of national VD, Articles 7(1)(c) and 7(1)(d) might be applicable (see paragraphs 2.3 and 2.4).

2.7.2 Accepted principles of morality

This objection concerns subjective values, but these must be applied as objectively as possible by the examiner. The provision excludes registration as Community trade marks of blasphemous, racist or discriminatory words or phrases, but only if that meaning is clearly conveyed by the mark applied for in an unambiguous manner; the standard to be applied is that of the reasonable consumer with average sensitivity and tolerance thresholds (judgment of 09/03/2012, T-417/10, '¡Que bueno ye! Hijoputa', para. 21).

It is normally necessary to consider the goods and services for which registration of the mark is sought, since the relevant public may be different for different goods and services and, therefore, may have different thresholds with regard to what is clearly unacceptably offensive. For example, as the Grand Board held in its decision of 06/07/2006, R 0495/2005-G – 'SCREW YOU', para. 29, 'a person who is sufficiently interested in [sex toys] to notice the trade marks under which they are sold is unlikely to be offended by a term with crude sexual connotations.' Nevertheless, although the Court has held that the goods and services applied for are important for identifying the relevant public whose perception needs to be examined, it has also made it clear that the relevant public is not necessarily only that which buys the goods and services covered by the mark, since a broader public than just the consumers targeted may encounter the mark (judgment of 05/10/2011, T-526/09, 'Paki', paras 17 and 18 respectively). Accordingly, the commercial context of a mark, in the sense of the public targeted by the goods and services, is not always the determining factor in whether that mark would breach accepted principles of morality (judgment of 09/03/2012, T-417/10, '¡Que bueno ye! Hijoputa', para. 24). See also decision of 15/03/2013, R 2073/2012-4, – 'CURVE', paras 17-18 (T-266/13 – pending).

It is not only signs with 'negative' connotation that can be offensive. The banal use of some signs with a highly positive connotation can also be offensive (e.g. terms with a religious meaning or national symbols with a spiritual and political value, like ATATURK for the European general public of Turkish origin (decision of 17/09/2012, R 2613/2011-2 – ATATURK, para. 31)).

There need not be illegality for this part of Article 7(1)(f) CTMR to be applied: there are words or signs that would not lead to proceedings before the relevant authorities and courts, but that are sufficiently offensive to the general public to not be registered as trade marks (decision of 01/09/2011, R 0168/2011-1 – ‘fucking freezing! by TÜRPIITZ’, para. 16). Furthermore, there is an interest in ensuring that children and young people, even if they are not the relevant public of the goods and services in question, do not encounter offensive words in shops that are accessible to the general public. Dictionary definitions will in principle provide a preliminary indication as to whether the word in question carries an offensive meaning in the relevant language (decision of 01/09/2011, R 0168/2011-1 – ‘fucking freezing! by TÜRPIITZ’, para. 25) but the key factor must be the perception of the relevant public in the specific context of how and where the goods or services will be encountered.

On the other hand, the Board of Appeal took the view that the word KURO did not convey to the Hungarian public the offensive meaning of the word ‘kúró’ (meaning ‘fucker’ in English), since the vowels ‘ó’ and ‘ú’ are separate letters which are distinct from ‘o’ and ‘u’ and they are pronounced differently (decision of 22/12/2012, R 482/2012-1 – ‘kuro’, paras 12 et seq.).

There is a clear risk that the wording of Article 7(1)(f) CTMR could be applied subjectively so as to exclude trade marks that are not to the examiner’s personal taste. However, for the word(s) to be objectionable, it (they) must have a clearly offensive impact on people of normal sensitivity (judgment of 09/03/2012, T-417/10, ‘¡Que buenu ye! Hijoputa’, para. 21).

The concept of morality in Article 7(1)(f) CTMR is not concerned with bad taste or the protection of individuals’ feelings. In order to fall foul of Article 7(1)(f) CTMR, a trade mark must be perceived by the relevant public, or at least a significant part of it, as going directly against the basic moral norms of the society.

There is no need to establish that the applicant *wants* to shock or insult the public concerned; the objective fact that the CTM applied for *might* be seen as such a shock or insult is sufficient (decision of 23/10/2009, R 1805/2007-1 – ‘Paki’, para. 27, confirmed by judgment of 05/10/2011, T-526/09, ‘Paki’ para. 20 et seq.).

Finally, application of Article 7(1)(f) CTMR is not limited by the principle of freedom of expression (Article 10 European Convention on Human Rights) since the refusal to register only means that the sign is not granted protection under trade mark law and does not stop the sign being used – even in business (judgment of 09/03/2012, T-417/10, ‘HIJOPUTA’, para. 26).

Examples of rejected CTMAs (public policy and/or morality)

Sign	Relevant Consumer	Public policy / morality	Case No
BIN LADIN	General consumer	Morality & public policy – the mark applied for will be understood by the general public as the name of the leader of the notorious terrorist organisation Al Qaeda; terrorist crimes are in breach of public order and moral principles (para. 17).	R 0176/2004-2

Sign	Relevant Consumer	Public policy / morality	Case No
CURVE 300	General consumer	Morality – ‘CURVE’ is an offensive and vulgar word in Romanian (it means ‘whores’).	R 0288/2012-2
CURVE	General consumer	Morality – ‘CURVE’ is an offensive and vulgar word in Romanian (it means ‘whores’).	R 2073/2012-4 (T-266/13 – pending)
	General consumer	Morality – ‘fucking’ is an offensive and vulgar word in English.	R 0168/2011-1
	General consumer	Morality – ‘HIJOPUTA’ is an offensive and vulgar word in Spanish.	T-417/10
	General consumer	Public policy – the Hungarian criminal code bans certain ‘symbols of despotism’, including the hammer and sickle as well as the 5-pointed red star symbolising the former USSR. This law is not applicable by reason of its normative value but rather as evidence of the perception of the relevant public (paras 59-63).	T-232/10
PAKI	General consumer	Morality– ‘PAKI’ is a racist insult in English.	T-526/09
SCREW YOU	General consumer (for products other than sex products)	Morality – a substantial proportion of ordinary citizens in Britain and Ireland would find the words ‘SCREW YOU’ offensive and objectionable (para. 26).	R 0495/2005-G
FICKEN	General consumer	Morality - ‘FICKEN’ is an offensive and vulgar word in German (it means ‘fuck’).	T-52/13
ATATURK	Average consumer in the European general public of Turkish origin	Banal use of signs with a highly positive connotation can be offensive under Article 7(1)(f). ATATURK is a national symbol with a spiritual and political value for the European general public of Turkish origin.	R 2613/2011-2

Examples of accepted CTMAs

Sign	Relevant Consumer	Public policy / morality	Case No
KURO	General consumer	The fact that a foreign term, name or abbreviation displays certain similarities with an offensive word (like kúró) is not in itself sufficient reason to refuse the CTM applied for (para. 20). Hungarian vowels ‘ö’ and ‘ü’ are clearly different from ‘o’ and ‘u’ without accent. Furthermore, Hungarian words never end with ‘o’ without accent (paras 15-18).	R 482/2012-1

Sign	Relevant Consumer	Public policy / morality	Case No
SCREW YOU	General consumer (for sex products)	A person entering a sex shop is unlikely to be offended by a trade mark containing crude, sexually charged language (para. 26).	R 495/2005-G
DE PUTA MADRE	General consumer	Although 'puta' means 'whore' in Spanish, the expression DE PUTA MADRE means 'very good' in Spanish (slang).	CTM 3 798 469 CTM 4 781 662 CTM 5 028 477

2.8 Deceptiveness: Article 7(1)(g) CTMR

2.8.1 Examination of the deceptive character

Article 7(1)(g) CTMR provides that marks which are of such a nature as to deceive the public, for instance, as to the nature, quality or geographical origin of the goods or services, shall not be registered.

According to the case-law relating to Article 3(1)(g) of the First Trademark Directive (TMD), the wording of which is identical to that of Article 7(1)(g) CTMR, the circumstances for refusing registration referred to in Article 7(1)(g) CTMR presuppose the **existence of actual deceit or a sufficiently serious risk that the consumer will be deceived** (see judgment of 30/05/2006, C-259/04, 'Elizabeth Emanuel', para. 47 and the case-law cited therein).

Pursuant to the above, the Office, as a matter of practice, makes the twin assumptions that:

1. There is no reason to assume that a trade mark is intentionally applied for to deceive customers. No deceptiveness objection should be raised if a non-deceptive usage of the mark is possible *vis-à-vis* the goods and services specified: i.e. an assumption is made that non-deceptive use of the sign will be made if possible,
2. The average consumer is reasonably attentive and should not be regarded as particularly vulnerable to deception. An objection will generally only be raised where the mark leads to a **clear** expectation which is **patently contradictory** to, for instance, the nature or quality or geographical origin of the goods.

An objection should be raised when the list of goods/services is worded in such a way that a non-deceptive use of the trade mark is impossible.

The following are two examples of marks which were found to be deceptive with regard to all or part of the claimed goods².

Mark and goods	Reasoning	Case
<p>LACTOFREE for <i>lactose</i> in Class 5</p>	<p>The nature of the sign would immediately lead the relevant consumer to believe that the product in question, i.e. 'lactose', does not contain any lactose. It is clear that if the good being marketed under the sign 'LACTOFREE' is actually <i>lactose</i> itself, then the mark would be clearly misleading. NB: The mark is also objectionable under 7(1)(c)</p>	<p>R 892/2009-1</p>
<p>TITAN (German word for 'titanium') for <i>portable and relocatable buildings; modular portable building units for use in the construction of prefabricated relocatable buildings; prefabricated relocatable buildings constructed of modular portable building units, none of the aforesaid goods being made from or including titanium</i> in Classes 6 and 19.</p>	<p>The applicant, during the appeal proceedings, in an attempt to overcome an objection of descriptiveness, offered to restrict the specifications in both classes by adding, at the end, the indication <i>none of the aforesaid goods being made from or including titanium</i>. The Board held that such a restriction, if accepted, would have had the effect of rendering the trade mark deceptive from the standpoint of the German-speaking public, as they would assume that the goods were made from titanium when in reality this is not the case.</p>	<p>R 789/2001-3</p>

An objection should be raised when the list of goods/services, worded in a detailed manner, contains goods/services in respect of which a non-deceptive use is impossible.

In the (invented) case of a trade mark 'KODAK VODKA' for *vodka, rum, gin, whisky*, an objection should be raised in respect of the specific goods in respect of which a non-deceptive use of the trade mark is not possible, i.e. *rum, gin, whisky*. Such cases are substantially different from those (see here below) where broad wording/categories are used and where a non-deceptive use of the sign is possible. For example, no objection would be raised in respect of 'KODAK VODKA' filed for *alcoholic beverages*, since this broad category includes vodka, in respect of which the trade mark is not deceptive.

No objection should be raised when the list of goods/services is worded in such a broad way that a non-deceptive use is possible.

When **wide categories** in the list of goods/services are used, the question arises whether an objection should be raised in relation to an entire category due to the mark being deceptive in relation to only some goods/services falling within that category. The

² These examples address only the issue of whether a deceptiveness objection should be raised or not. This paragraph does not deal with possible objections under other absolute grounds for refusal. Therefore, the possibility that a given trade mark might appear to be prima facie objectionable under Article 7(1)(b) and/or (c) CTMR (or other provisions for that matter) is not contemplated here.

policy of the Office is not to object in these circumstances. The examiner should assume that the mark will be used in a non-deceptive manner. In other words they will not object on the basis of deceptiveness wherever they can pinpoint (in a category) a non-deceptive use.

Therefore, the rule is that **Article 7(1)(g) CTMR does not apply if the specification consists of wide categories which include goods/services for which use of the trade mark would be non-deceptive**. For example, in the case of a trade mark 'ARCADIA' applied for 'wines', an objection under Article 7(1)(g) CTMR would not be appropriate, since the broad category 'wines' also covers wines originating from Arcadia (and since Arcadia – which identifies a wine-producing region in Greece – is not a protected geographical indication at Community level, there is no obligation on the part of the applicant to restrict the specification only to wines originating from Arcadia).

2.8.2 Market reality and consumers' habits and perceptions

When assessing if a given trade mark is deceptive or not, **account should be taken of market reality and consumers' habits and perceptions**.

In order to evaluate the deceptiveness of a trade mark under Article 7(1)(g) CTMR, account must be taken of the **reality of the market** (i.e. the way the goods and services are normally distributed/held out for sale/purchased/rendered, etc.) as well as of the **consumption habits and perception of the relevant public**, which is normally composed of reasonably well-informed, observant and circumspect persons.

For example, in the (invented) trade mark '**ELDORADO CAFÈ LATINO**' covering *coffee, preparations for use as substitutes for coffee, artificial coffee, chicory, chicory flavourings; chocolate, preparations for use as substitutes for chocolate; tea, cocoa; sugar, rice, tapioca, sago; flour and preparations made from cereals, bread, pastry and confectionery, ices; honey, treacle; yeast, baking-powder; salt, mustard; vinegar, sauces (condiments); spices; ice* in Class 30, the examination should lead to the following conclusions:

- An objection under Article 7(1)(g) CTMR would be justified in relation to preparations for use as substitutes for coffee, artificial coffee, chicory, chicory flavourings because use of the mark on these goods would be necessarily deceptive. One would assume one was purchasing coffee and this would not in fact be the case.
- An objection under Article 7(1)(g) CTMR would also be justified in respect of tea. Given that such goods may be sold in packaging quite similar to those used for coffee, and are often bought rather hastily, it is likely that many consumers will not indulge in analysing the wording on the packaging, but will choose these goods from the shelf in the (erroneous) belief that they are *coffee*.
- However, as far as coffee is concerned, there is no 'clear contradiction' between the claim for *coffee* and the wording 'CAFÈ LATINO', since the general category *coffee* may include also coffee originating from Latin America. Hence no Article 7(1)(g) CTMR objection arises for the category of *coffee* itself. The same logic applies in relation to goods which could be flavoured with coffee (such as *chocolate, ices* and *pastry and confectionery*) – an assumption of non-deceptive

use should be made, and no contradiction between the said wording and the goods necessarily arises.

- Finally, for the remainder of the goods are concerned, i.e. honey, bread, vinegar etc., the presence of the wording 'CAFÈ LATINO' will not give rise to any expectations at all. In relation to such goods, this wording will be seen as clearly non-descriptive and hence there is no potential for actual deception. In the 'real' market, coffee is not displayed on the same shelves or shop sections as bread, honey or vinegar. Furthermore, the goods in question have a different appearance and taste and are normally distributed in different packaging.

2.8.3 Trade marks with geographical connotations relating to the location of the applicant or the place of origin of the goods/services

When it comes to trade marks having certain 'geographical' connotations relating to the location of the applicant or the place of origin of the goods/services, the following should be noted.

As a general rule, the Office will not raise an objection on deceptiveness based upon the applicant's geographical location (address). Indeed, such a geographical location bears, in principle, no relation to the geographical origin of the goods and services, i.e. the actual place of production/offering of the goods and services covered by the mark.

As an example, a figurative mark containing the words **MADE IN USA** for *clothing* in Class 25 filed by a company having its seat in Sweden would not be open to an objection under Article 7(1)(g) CTMR. In such cases, the Office assumes a non-deceptive use of the mark on the part of the proprietor.

Deceptiveness would nonetheless arise in the hypothetical event that a figurative mark containing the words **MADE IN USA**, filed by a company having its seat in the United States of America, were filed for a specifically limited list of goods: *clothing articles made in Vietnam* – although, in practice, such cases seem unlikely to arise.

In certain cases, the sign could evoke in the consumers' minds some impressions/expectations as to the geographical origin of the goods or of the designer thereof and which may not correspond to reality. For example, trade marks such as **ALESSANDRO PERETTI** or **GIUSEPPE LANARO** (invented examples) covering clothing or fashion goods in general may suggest to the relevant public that these goods are designed and produced by an Italian stylist, which may not be the case.

However, such a circumstance is not sufficient per se to render those marks misleading. Indeed, 'false impressions/expectations' caused by the trade mark are not tantamount to actual deceptiveness when the sign is merely evocative. In such cases there is no clear contrast between the impression/expectation a sign may evoke and the characteristics/qualities of the goods and services it covers.

2.8.4 Trade marks making reference to an 'official' approval, status or recognition

It should be noted that, under the Office practice, trade marks which could evoke official approval, status or recognition without giving the firm impression that the

goods/services issue from, or are endorsed by, a public body or statutory organisation, are acceptable.

The following are two examples where the marks concerned, although allusive or suggestive, were not found to be deceptive:

Mark and services	Reasoning	Case
<p>THE ECOMMERCE AUTHORITY</p> <p>for <i>business services, namely, providing rankings of and other information regarding electronic commerce vendors, goods and services via the Internet in Class 35 and providing research and advisory services and information in the area of electronic commerce in Class 42.</i></p>	<p>The Board found that the trade mark was not deceptive, as it did not convey the firm impression that the services issue from a governmental or statutory organisation (the Board, however, confirmed the refusal under Article 7(1)(b) on the grounds that the mark lacked distinctive character, as it would be perceived by the English-speaking public merely as a simple statement of self-promotion which claims something about the level of competence of the service providers).</p>	<p>R 803/2000-1</p>
 <p>for, among other things, <i>teaching of ski in Class 41.</i></p>	<p>The Board held that the French consumers would understand that the trade mark alludes to the fact that the services are supplied in France, by a French teaching centre, and relate to learning skiing 'in the French way'. It added that the French public had no reason to believe, simply because of the presence of a tricolour logo (not being a reproduction of the French flag), that the services are supplied by public authorities or even authorised by such authorities.</p>	<p>R 235/2009-1 confirmed by the General Court in T-41/10</p>

2.8.5 Relation with other CTMR provisions

The above explanations aim to define the scope of application of Article 7(1)(g) CTMR. Although addressed in their respective sections of the Guidelines, in the context of absolute grounds examination and of possible deceptiveness scenarios, the following provisions may be of particular relevance.

Article 7(1)(b) and (c) CTMR

Under the current practice of the Office, if, following a descriptiveness and/or lack of distinctiveness objection, the CTM applicant proposes a limitation in an attempt to overcome it, and provided the proposed limitation meets the prescribed requirements (unconditional request and suitably worded), the original list of goods and/or services will be limited accordingly. However, if the limitation in question (albeit overcoming the initial objection) has the effect of rendering the trade mark applied for deceptive, then the examiner will have to raise a deceptiveness objection under Article 7(1)(g) CTMR. The following example illustrates such a scenario:

The trade mark '**ARCADIA**' was originally applied in respect of *wines, spirits (beverages) and liqueurs* in Class 33. The examiner objected because the trade mark was descriptive of the geographical origin of wines, to the extent that Arcadia is a

Greek region known for its wine production (however, it should be noted that Arcadia is not a protected geographical indication). The applicant offered to limit the specification of goods to exclude wines made in Greece or, if preferred, to include only wines produced in Italy. The examiner held that the proposed limitation would render the trade mark deceptive since it would convey false information as to the origin of the goods. On appeal, the Board confirmed the reasoning of the examiner (see decision of 27/03/2000, R 246/1999-1 – ‘ARCADIA’, para. 14).

Article 7(1)(h) CTMR

This provision excludes from registration those CTMs which consist of/contain flags and other symbols of States, on the one hand, and flags and other symbols of international intergovernmental organisations on the other, which are protected according to Article 6ter of the Paris Convention and the inclusion of which in the trade mark has not been expressly authorised by the competent authorities. When it comes to the flags and other symbols of international intergovernmental organisations, the problem arises when the public might erroneously believe that, in view of the goods/services concerned, there is a connection between the CTM applicant and the international organisation whose flag or symbol appears in the CTM.

Articles 7(1)(j) and (k) CTMR (protected geographical indications)

These provisions exclude trade marks for wines or spirits, on the one hand, and other agricultural foodstuffs on the other, which contain or consist of protected geographical indications (PGIs) or protected geographical denominations (PDOs) where the list of the respective goods does not specify that they have the purported geographical origin. Under the directly applicable rules of the corresponding specific EU Regulations underlying those provisions, the Office must object to CTM applications where the protected geographic indication is misused or which convey any other false or misleading indication as to the provenance, origin, nature or essential qualities of the products concerned.

Article 17(4) CTMR (transfer)

Under this provision, where it is clear from the transfer documents that, because of the transfer, the CTM is likely to mislead the public concerning the nature, quality or geographical origin of the goods or services in respect of which it is registered, the Office will not register the transfer unless the successor agrees to limit (the) registration of the CTM to goods or services in respect of which it is not likely to mislead (see also Part E, Section 3, Chapter 1, paragraph 3.6).

Article 51(1)(c) CTMR (grounds for revocation)

Whereas in examining a trade mark under Article 7(1)(g) CTMR an examiner must confine the assessment to the meaning conveyed by the sign vis-à-vis the goods/services concerned (meaning that the way the sign is actually used is of no relevance), under Article 51(1)(c) CTMR the way the sign is used is decisive, given that according to this provision a registered CTM may be declared revoked if, in consequence of the use made of the sign by its proprietor or with their consent, the

trade mark is liable to mislead the public, particularly as to the nature, quality or geographical origin of the goods/services concerned.

2.9 Protection of flags and other symbols – Articles 7(1)(h) and (i) CTMR

The objective of Article 6*ter* Paris Convention (PC) is to exclude the registration and use of trade marks that are identical or in some way similar to state emblems or the emblems, abbreviations and names of international intergovernmental organisations.

‘The reasons for this are that such registration or use would violate the right of the State to control the use of symbols of its sovereignty and furthermore might mislead the public with respect to the origin of goods to which such marks would be applied.’ (G.H.C. Bodenhausen, Guide to the application of the Paris Convention for the Protection of Industrial Property as revised in Stockholm in 1967, page 96.). Origin in this regard must be understood as coming from or endorsed by the relevant administration, not as being produced in the territory of that state or, in the case of the EU, in the EU.

Article 7(1)(h) CTMR therefore refers to the following symbols:

- Armorial bearings, flags, other emblems, official signs and hallmarks that belong to states and have been communicated to WIPO, although, in the case of flags, such communication is not mandatory.
- Armorial bearings, flags, other emblems, abbreviations and names of international intergovernmental organisations that have been communicated to WIPO, with the exception of those already the subject of international agreements for ensuring their protection (see, for example, the Geneva Convention for the Amelioration of the Condition of the Wounded and Sick in Armed Forces of 12/08/1949, Article 44 of which protects the emblems of the Red Cross on a white ground, the words ‘Red Cross’ or ‘Geneva Cross’, and analogous emblems).

The Court of Justice has made clear that these provisions can be applied regardless of whether the application concerns goods or services, and that the scopes of application of Article 7(1)(h) and 7(1)(i) CTMR are analogous. Both articles should therefore be assumed to grant at least an equivalent level of protection, since they pursue the same objective, that is, to prohibit the use of specific emblems of public interest without the consent of the competent authorities (see judgment of 16/07/2009 in Joined Cases C-202/08 P and C-208/08 P, ‘RW feuille d’érable’, paras 78, 79 and 80).

2.9.1 Protection of armorial bearings, flags, other state emblems, official signs and hallmarks indicating control and warranty under Article 7(1)(h) CTMR – Article 6*ter*(1)(a) and (2) PC

In accordance with Article 6*ter*(1)(a) PC, the registration, either as a trade mark or as an element thereof, of armorial bearings, flags, and other state emblems of the countries of the Union (i.e. the countries to which the PC applies), or of official signs and hallmarks adopted by states as an indication of control and warranty, as well as

any imitation from a heraldic point of view will be refused if no authorisation has been granted by the competent authority.

The members of the World Trade Organization (WTO) enjoy the same protection pursuant to Article 2(1) TRIPs, according to which members of the WTO must comply with Articles 1 to 12 and 19 PC.

Therefore, to fall foul of Article 7(1)(h) CTMR, a trade mark:

- must consist solely of an identical reproduction or a ‘heraldic imitation’ of the abovementioned symbols;
- must contain an identical reproduction or a ‘heraldic imitation’ of the abovementioned symbols.

Furthermore, the competent authority must not have given its authorisation.

Armorial bearings consist of a design or image depicted on a shield. See the following example.



Bulgarian armorial bearing – 6^{ter} database No BG2

State flags usually consist of a distinctive rectangular design that is used as the symbol of a nation. See the following example.



Croatian flag

The expression ‘other State emblems’ is rather vague. It usually indicates any emblems constituting the symbol of the sovereignty of a State, including the escutcheons of reigning houses as well as emblems of States included in a federative state that is party to the Paris Convention. See the following example.

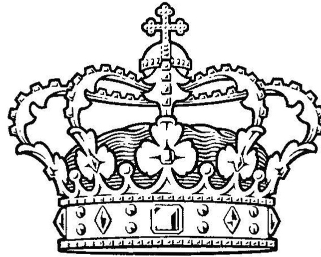

Danish state emblem – 6ter database No DK3

The purpose of official signs and hallmarks indicating control and warranty is to certify that a state or an organisation duly appointed by a state for that purpose has checked that certain goods meet specific standards or are of a given level of quality. There are official signs and hallmarks indicating control and warranty in several states for precious metals or products such as butter, cheese, meat, electrical equipment, etc. Official signs and hallmarks may also apply to services, for instance those relating to education, tourism, etc. See the following examples.



Official Spanish sign for export promotion No ES1



UK hallmark for platinum articles No GB 40

It must be noted that Article 6ter PC does not protect the abovementioned symbols against all imitations, only 'heraldic imitations'. The notion of 'heraldic imitation' must be construed in the sense that '... the prohibition of the imitation of an emblem applies only to imitations of it from a heraldic perspective, that is to say, those which contain heraldic connotations which distinguish the emblem from other signs. Thus, the protection against any imitation from a heraldic point of view refers not to the image as such, but to its heraldic expression. It is therefore necessary, in order to determine whether the trade mark contains an imitation from a heraldic point of view, to consider the heraldic description of the emblem at issue' (see CJEU judgment of 16/07/2009 in Joined Cases C-202/08 P and C-208/08 P, para. 48).

Consequently, when making a comparison ‘from a heraldic point of view’ within the meaning of Article 6ter PC, account must be taken of the heraldic description of the emblem concerned and not any geometric description of the same emblem, which is by nature much more detailed. Indeed, if the geometric description of the emblem were taken into account, this ‘... would lead to the emblem being refused protection under Article 6ter(1)(a) of the Paris Convention in the event of any slight discrepancy between the two descriptions. Secondly, the case of graphic conformity with the emblem used by the trade mark is already covered by the first part of that provision, so that the expression “any imitation from a heraldic point of view” must be different in its scope’ (see *ibidem*, para. 49).

For example, an examiner should take into account the heraldic description of the



European emblem – ‘on an azure field a circle of twelve golden mullets, their points not touching’ – and not its geometrical description: ‘the emblem is in the form of a blue rectangular flag of which the fly is one and a half times the length of the hoist. Twelve gold stars situated at equal intervals form an invisible circle whose centre is the point of intersection of the diagonals of the rectangle. The radius of the circle is equal to one third of the height of the hoist. Each of the stars has five points which are situated on the circumference of an invisible circle whose radius is equal to one eighteenth of the height of the hoist. All the stars are upright — that is to say, with the one point vertical and two points in a straight line at right angles to the mast. The circle is arranged so that the stars appear in the position of the hours on the face of a clock. Their number is invariable.’

Furthermore, armorial bearings and other heraldic emblems are drawn on the basis of a relatively simple description of the layout and background colour that also lists the different elements (such as a lion, an eagle, a flower, etc.) constituting the emblem and gives information on their colour and position within the emblem. However, a heraldic description does not give details of the design of the emblem and the specific elements that constitute it, with the result that a number of artistic interpretations of one and the same emblem on the basis of the same heraldic description are possible. Although there may be differences in detail between each of those interpretations, the fact remains that they will all be imitations ‘from a heraldic point of view’ of the emblem concerned (T-215/06, 28/02/2008, paras 71 and 72).

It follows that a trade mark that does not exactly reproduce a state emblem can nevertheless be covered by Article 6ter(1)(a) PC where it is perceived by the relevant public as imitating such an emblem. So far as the expression ‘imitation from a heraldic point of view’ in that provision is concerned, a difference detected by a specialist in heraldic art between the trade mark applied for and the State emblem will not necessarily be perceived by the average consumer who, in spite of differences at the level of certain heraldic details, can see in the trade mark an imitation of the emblem in question (see CJEU judgment of 16/07/2009 in Joined Cases C-202/08 P and C-208/08 P, paras 50 and 51).

Furthermore, for Article 6ter(1)(a) PC to apply, it is not necessary to examine the overall impression produced by the mark by taking into account also its other elements (words, devices, etc.).

Indeed, Article 6ter(1)(a) PC applies not only to trade marks but also to elements of marks that include or imitate state emblems. It is sufficient, therefore, for a single element of the trade mark applied for to represent such an emblem or an imitation thereof for that mark to be refused registration as a Community trade mark (see also judgment of 21/04/2004, T-127/02, 'ECA', paras 40 to 41).

2.9.1.1 Examination of marks consisting of or containing a state flag

There are three steps to examining marks that consist of or contain a state flag:

- 1 Find an official reproduction of the protected flag.
- 2 Compare the flag with the mark applied for. Does the mark applied for consist solely of or contain an identical reproduction of the flag (b)? Or does the mark consist solely of or contain a heraldic imitation of that flag (b)?
- 3 Check whether there is any evidence on file to show that registration of the flag has been authorised by the competent authority.

1 Find the protected flag

As seen above, states are not obliged to include flags in the list of emblems to be communicated to WIPO. This is because flags are supposed to be well known.

Nevertheless, some flags have been included in the list, which is accessible via the 'Article 6ter Structured Search' tool made available by WIPO. Otherwise, examiners should refer to the official websites of the relevant governments, and to encyclopaedias and/or dictionaries for an accurate reproduction of the state flag.

2 Compare the flag with the mark applied for

- (a) Does the mark applied for consist solely of or contain an identical reproduction of a flag? If so, proceed to the next step.
- (b) Does the mark consist solely of or contain a heraldic imitation of a flag?

In the case of flags, the mark must be compared with the heraldic description of the flag at issue. For example, in Case T-41/10 of 05/05/2011 (ESF Ecole du ski français), the French flag was described as a rectangular or square flag made up of three equal vertical bands of the colours blue, white and red.

The examiner will use the heraldic description, which gives details of the layout and background colour, lists the different elements (such as a lion, an eagle, a flower, etc.) that constitute the flag and specifies the colour, position and proportions of the latter to reach a conclusion on heraldic imitation.

As a rule, the flag and the mark (or the part of the mark in which the flag is reproduced) must be quite similar in order for a heraldic imitation to be found.

See the following example where a ‘heraldic imitation’ of a flag was found:

Flag	Refused CTMA
	
Swiss flag	CTMA 8 426 876

The use of a flag in black and white may still be considered a heraldic imitation when the flag consists of or contains unique heraldic features. For example, the black-and-white representation of the Canadian flag in the following example is considered to be a heraldic imitation.

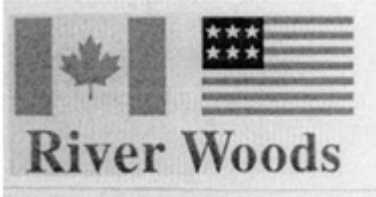

Flag	Refused CTMA
	
Canadian flag	CTMA 2 793 495

On the other hand, for flags consisting only of stripes of three colours (whether vertical or horizontal) a black-and-white reproduction will not be considered a heraldic imitation because flags of that kind are quite common.





As seen above, the presence of other elements in the marks is irrelevant; this is confirmed by the Board of Appeal’s refusal of CTMA 10 502 714.

Flag	Sign
<p>The flags of, for example, Belgium, Czech Republic, France, Italy, Latvia, Austria, Finland and Sweden.</p>	 <p>CTMA 10 502 714, R 1291/2012-2</p>
<p>'... the flags ... are all represented in the mark and will be immediately recognized as such by the public coming from those parts of the EU, as well as many others across the relevant territory. ... they do not merge into each other in a way which dissipates their individual characteristics. It must also be noted that the flags appearing at the bottom of the mark ... are not upside down, but are presented exactly as they would be normally.</p> <p>As noted by the Court in the judgment of 16 July 2009, C-202/08 P and C-208/08 P, 'RW feuille d'érable' at para. 59, Article 6ter(1)(a) of the Paris Convention applies not only to trade marks but also to elements of marks which include or imitate State emblems. It is sufficient, therefore, for a single element of the trade mark applied for to represent such an emblem or an imitation thereof for that mark to be refused registration as a Community trade mark ... Therefore the applicant's arguments that although the mark contains various national flags, this is only a small part of the mark which is overwhelmed by the presence of the additional elements and that these elements are more dominant and distinctive, fail.' (paras 18-19)</p>	

If an element is a different shape from a flag (e.g. circular), it is not considered to be a heraldic imitation. Other different shapes that are not heraldic imitations are shown in the following examples:

Flag	Accepted CTMA
	
	<p>CTMA 5 851 721</p>
<p>Italian flag</p>	 <p>CTMA 5 514 062</p>

	
<p>Swiss flag</p>	<p>CTMA 6 015 473</p>
	
<p>Finnish flag</p>	<p>CTMA 7 087 281</p>

Flag	Accepted CTMA
	
<p>Swedish flag</p>	<p>CTMA 8 600 132</p>
	
<p>Danish flag</p>	<p>CTMA 8 600 173</p>
	
<p>French flag</p>	<p>CTM 4 624 987, T-41/10</p>

The distinction between the cases examined in CTMA No 8 426 876 (objected to) and CTMA No 6 015 473 (not objected to) should be noted. In the latter, it was decided not to object because of the number of changes: a change in the shape (from a square to a circle), a change in proportions (the white lines of the cross in CTMA No 6 015 473 are

longer and thinner than in the flag) and a change of colour, since the cross in CTMA No 6 015 473 has a shadow.

3 Check whether registration has been authorised

Once the examiner has found that the mark consists of or contains a flag or a heraldic imitation thereof, he/she must check whether there is any evidence on file to show that the registration has been authorised by the competent authority.

Where there is no such evidence, the examiner will object to the registration of the mark applied for. The objection will reproduce the official flag in colour and indicate the source of the reproduction.

Such an objection can only be waived if the applicant produces evidence that the competent authority of the state concerned has authorised registration of the mark.

Extent of the refusal: In the case of state flags, trade marks that fall foul of Article 7(1)(h) CTMR must be refused for all goods and services applied for.

2.9.1.2 Examination of marks consisting of or containing armorial bearings and other state emblems

The same steps mentioned in relation to State flags are followed also when examining marks that consist of or contain armorial bearings or other state emblems.





Nevertheless, to be protected, armorial bearings and other state symbols must be contained in 'the list of armorial bearings and state emblems'. This list is accessible via the 'Article 6ter Structured Search' tool made available by WIPO at <http://www.wipo.int/ipdl/en/6ter/>.

The WIPO Article 6ter database gives details of written elements and contains references to the categories of the Vienna classification code. Therefore, the best way to search is by using that code.

In these cases, the protected symbol, which very often consists of or contains recurring devices such as crowns, unicorns, eagles, lions, etc., and the mark (or the part of the mark in which the symbol is reproduced) must be closely similar.

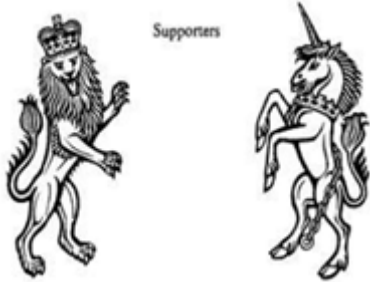

For background on this and other heraldic descriptions, please see the explanation in paragraph 2.8.1.1 'Examination of marks consisting of or containing a state flag' above.

Here are two examples where a 'heraldic imitation' of a state symbol was found:

Protected emblem	Refused CTMA
 <p style="text-align: center;">Supporters</p>	
British emblem: 6ter Number: GB4	CTMA 5 627 245, T-397/09
	
Canadian emblem: 6ter Number: CA2	CTMA 2 785 368 (CJEU C-202/08)

The General Court noted that the supporters contained in CTMA No 5 627 245 were almost identical to those in the emblem protected under sign GB4. The only difference lay in the crowns in both signs. However, the GC ruled that any difference between the mark and the state emblem detected by an expert in heraldry would not necessarily be perceived by the average consumer who, despite some differences in heraldic details, can see in the mark an imitation of the emblem. Therefore, the GC concluded that the Board was right to find that the mark applied for contained an imitation from a heraldic perspective of emblem GB4, protected under Article 6ter of the Paris Convention (Case T-397/09, paras 24-25).

In the example reproduced below a 'heraldic imitation' of state emblems was found by the examiner. However, the decision was annulled by the Board which considered that the sign applied for is not identical to the national emblem of Ireland. It does not contain an imitation of the national emblems of Ireland either and it does not reproduce characteristic heraldic features of these emblems (R 0139/2014-5, para. 16):



State emblem	CTMA
	
Irish state emblems: 6ter Numbers: IE 11 - IE 14	CTMA 11 945 797

It should also be noted that black-and-white reproductions of armorial bearings and other state emblems may still be considered heraldic imitations when the protected symbol consists of or contains unique heraldic features (see the example of the Canadian emblem).

Furthermore, the presence of other elements in the rejected marks is irrelevant.

There is even a heraldic imitation when the protected symbol is only partially reproduced as long as what is partially reproduced represents the significant element(s) of the protected symbol and (a) unique heraldic feature(s).

The following is an example of a partial heraldic imitation because the significant element of the protected symbol, the eagle with the arrows over the emblem, is a unique heraldic device and its heraldic characteristics are imitated in the CTMA:

Protected emblem	Refused CTMA
	
Emblem of the Justice Department of the USA; 6ter Number: US40	CTMA 4 820 213

In the following example there is no heraldic imitation of a state emblem:

Protected emblem	Accepted CTMA
	
6ter number: AT10	CTMA 8 298 077

CTMA No 8 298 077 is not a heraldic imitation of the Austrian symbol because its shape is different and the lines inside the white cross in the Austrian symbol are not present in the CTMA.

Once the examiner has found that a mark reproduces a symbol (or is a heraldic imitation thereof), they must check whether there is any evidence on file to show that registration has been authorised by the competent authority.

Where there is no such evidence, the examiner will object to the registration of the mark applied for. The objection will reproduce the protected symbol, quoting its 6ter number.

Such an objection can only be waived if the applicant produces evidence that the competent authority of the state concerned has authorised registration of the mark.

Extent of the refusal: In the case of state symbols, trade marks that fall foul of Article 7(1)(h) CTMR must be refused for all goods and services applied for.

2.9.1.3 Examination of marks consisting of or containing official signs and hallmarks indicating control and warranty

The steps to be followed by the examiner are the same as for the state flags, protected armorial bearings and other state emblems mentioned above.

However, the extent of the refusal is limited. Trade marks that consist of or contain an identical reproduction / heraldic imitation of official signs and hallmarks indicating control and warranty will be refused only for goods that are identical or similar to those to which said symbols apply (Article 6ter(2) PC).

2.9.2 Protection of armorial bearings, flags, other emblems, abbreviations and names of international intergovernmental organisations under Article 7(1)(h) CTMR – Article 6ter(1)(b) and (c) PC

In accordance with Article 6ter(1)(b) and (c) PC, the registration, either as a trade mark or as an element thereof, of armorial bearings, flags, other emblems, abbreviations and names of international intergovernmental organisations (of which one or more countries

of the Paris Union is / are member(s)) or any imitation from a heraldic point of view will be refused if no authorisation has been granted by the competent authority.

The members of the WTO enjoy the same protection pursuant to Article 2(1) TRIPs, according to which members of the WTO must comply with Articles 1 to 12 and 19 of the Paris Convention.

Furthermore, the trade mark should be of such a nature as to suggest to the public that there is a connection between the organisation concerned and the armorial bearings, flags, emblems, abbreviations or names, or to mislead the public as to the existence of a connection between the owner and the organisation.

International intergovernmental organisations (IGOs) include bodies such as the United Nations, the Universal Postal Union, the World Tourism Organization, WIPO, etc.

In this respect, the European Union must be considered neither as an international organisation in the usual sense nor as an association of states, but rather as a 'supranational organisation', i.e. an autonomous entity with its own sovereign rights and a legal order independent of the Member States, to which both the Member States themselves and their nationals are subject within the EU's areas of competence.

On the one hand, the Treaties have led to the creation of an independent Union to which the Member States have ceded some of their sovereign powers. The tasks allotted to the EU are very different from those of other international organisations. While the latter mainly have clearly defined tasks of a technical nature, the EU has areas of responsibility that together constitute essential attributes of statehood.



On the other hand, the EU institutions too only have powers in certain areas to pursue the objectives specified in the Treaties. They are not free to choose their objectives in the same way as a sovereign state. Moreover, the EU has neither the comprehensive jurisdiction enjoyed by sovereign states nor the powers to establish new areas of responsibility ('jurisdiction over jurisdiction').

Notwithstanding the particular legal nature of the EU, and for the sole purpose of the application of Article 7(1)(h), the European Union is likened to an international organisation. In practice, account will be taken of the fact that the EU's field of activity is so broad (see judgment of 15/01/2013, Case T-413/11 'EUROPEAN DRIVESHAFT SERVICES', para. 69) that the examiner is very likely to find a link between the goods and services in question and the EU's activities.



The most relevant EU flags and symbols, protected by the Council of Europe, are shown here:

	
6ter number: QO188	6ter number: QO189

The following have been protected for the Commission:

		
6ter number: QO245	6ter number: QO246	6ter number: QO247

The following have been protected for the European Central Bank:

	
6ter number: QO852	6ter number: QO867

There are four steps to examining marks that contain the armorial bearing, flag or other symbols of an international intergovernmental organisation.

- 1 Find an official reproduction of the protected symbol (which may be an abbreviation or name).
- 2 Compare the symbol with the mark applied for.
- 3 Check whether the mark applied for suggests to the relevant public that there is a connection between the owner and the international organisation or misleads the public as to the existence of such a connection.
- 4 Check whether there is any evidence on file to show that registration has been authorised by the competent authority.

- 1 Find the protected symbol (or abbreviation or name)

To be protected, the symbols of international intergovernmental organisations must be incorporated in the relevant list. Unlike the situation with state flags, this requirement also applies to international organisations' flags.

The relevant database is accessible via the 'Article 6ter Structured Search' tool provided by WIPO. In this case too, the best way to search is by using the Vienna classification code.

2 Compare the symbol with the mark applied for







Does the mark applied for consist solely of or contain an identical reproduction of the protected symbol of an international intergovernmental organisation Or does the mark applied for consist of or contain a heraldic imitation thereof?

- (a) Does the mark applied for consist solely of or contain an identical reproduction of the protected symbol? If so, proceed to the next step.
- (b) Does the mark applied for consist solely of or contain a heraldic imitation thereof?

The test is the same as that for state flags and symbols, that is, the protected symbol and the mark (or the part of the mark in which the protected symbol is reproduced) must be closely similar. The same applies to abbreviations and names of international intergovernmental organisations (see the Board’s decision in Case R 1414/2007-1 – ‘ESA’).

The following marks were rejected because they were considered to contain ‘heraldic imitations’ of the European Union flag protected under QO188:



		
CTMA 2 305 399	CTMA 448 266	CTMA 6 449 524
		
CTMA 7 117 658	CTMA 1 106 442 (T-127/02)	CTM 4 081 014 (1640 C)
		

	CTMA 2 180 800 (T-413/11)	
--	---------------------------	--

For heraldic imitations of the European Union flag (QO188 above), it is considered relevant that (a) there are 12 five-pointed stars, (b) the stars are in a circle and are not touching each other, and (c) the stars contrast with a darker background.

In particular, it must be taken into account that the ‘device in the form of twelve stars arranged in a circle is the most important element of the European Union emblem (‘the emblem’) because it conveys strong messages: (a) the circle of gold stars symbolises solidarity and harmony between the peoples of Europe and (b) the number twelve evokes perfection, completeness and unity. The other element of the emblem is a background suitably coloured to highlight the device’ (see BoA decision in case R 1401/2011-1, para. 21).

It follows from the above that the representation of the EU flag in black and white may still be considered a heraldic imitation when the stars contrast with a dark background in such a way as to give the impression of being a black-and-white reproduction of the EU flag (see CTMA 1 106 442 above).

In contrast, the following example illustrates a case where the black-and-white reproduction of a circle of stars does not give the impression of being a black-and-white reproduction of the EU flag:

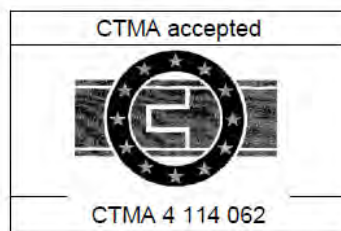

The following three cases are not considered to be heraldic imitations of the European Union flag because they do not reproduce twelve stars in a circle (i.e. both marks were accepted):



The following is not a heraldic imitation because, although the stars are yellow, there is no blue (or dark-coloured) background:

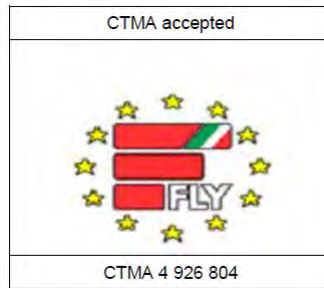

- 3 Check whether the mark applied for suggests to the relevant public that there is a connection between the owner and the international organisation or misleads the public as to the existence of such a connection.

A connection is suggested not only where the public would believe that the goods or services originate with the organisation in question, but also where the public could believe that the goods or services have the approval or warranty of, or are otherwise linked to, that organisation (see GC judgment of 15/01/2013, Case T-413/11, 'EUROPEAN DRIVESHAFT SERVICES', para. 61).

In order to assess the circumstances properly, the examiner must take into account the following:

- the goods and/or services covered by the CTM application;
- the relevant public;
- the overall impression conveyed by the mark.

With regard to the European Union flag, the examiner must evaluate whether there is any overlap between the claimed goods and / or services and the European Union's activities, bearing in mind that the European Union is active in numerous sectors and regulates goods and services in all fields of industry and commerce, as is clear from the wide variety of Directives that it has adopted. Likewise, the examiner must take into account that even average consumers could be aware of such activities, which means, in practice, that the examiner is very likely to find a link in most cases.



Finally, in contrast to Article 6ter(1)(a) PC, for which it is sufficient for the sign to consist of or contain the emblem or a heraldic imitation thereof, Article 6ter(1)(c) PC requires an overall assessment.

It follows that, unlike for state emblems and flags, the examiner must take into account also the other elements of which the mark is composed. For it cannot be ruled out that all the other elements of the sign could lead to the conclusion that the public would not connect the sign with an international intergovernmental organisation (see judgment of 15/01/2013, Case T-413/11 'EUROPEAN DRIVESHAFT SERVICES', para. 59).

Still with regard to the EU flag, it must be noted that, as a rule, word elements such as 'EURO'/'EUROPEAN' in a CTMA are likely to suggest a connection even more, since

they could be perceived as implying an official EU agency's approval, quality control or warranty services in respect of the claimed goods and services.

Here are two examples of where a connection with the EU was found:

	
G&S	<p>Class 16: <i>Periodical and other publications</i> Class 42: <i>Preparation of reports or studies relating to cars, motorcycles and bicycles</i></p>
Reasoning	<p>The mark was refused for all the goods and services for the following reasons: (26) Consumers in this market are aware of how important it is for companies that provide surveys and reports on expensive and potentially dangerous goods like vehicles to be credible. Consumers may also be aware that the European Union itself is involved in such activities through its association with Euro E.N.C.A.P., which provides motoring consumers with independent assessments of the safety and performance of cars sold on the European market. Given these facts, and the fact that the proprietor's mark contains a recognisable heraldic element of the European emblem, it is likely that the public would assume that the inclusion of the twelve gold stars of the EU emblem in the CTM pointed to a connection between the proprietor and the EU.</p>
	
G&S	<p>Class 9: <i>Computer hardware, computer software, recorded data carriers.</i> Class 41: <i>Arranging and conducting of colloquiums, seminars, symposiums, congresses and conferences; providing of tuition, instruction, training; consultancy on training and further training.</i> Class 42: <i>Creating, updating and maintenance of computer programs; computer program design; consultancy in the field of computers; rental of computer hardware and computer software; leasing access time to a computer database.</i></p>

Reasoning	<p>The mark was refused for all the goods and services for the following reasons: The Board of Appeal found that, contrary to what the applicant claimed, there was some overlap between the goods and services offered by the applicant and the activities of the Council of Europe and the European Union. The Board of Appeal referred, <i>inter alia</i>, to the Official Journal of the European Union, which is available on CD-ROM (i.e. on a record data carrier), to seminars, training programmes and conferences offered by the Council of Europe and the European Union in a variety of areas, and to a large number of databases made available to the public by those institutions, in particular EUR-Lex.</p> <p>Given the wide variety of services and goods that may be offered by the Council of Europe and the European Union, it cannot be ruled out, for the kind of goods and services for which registration was sought, that the relevant public might believe that there is a connection between the applicant and those institutions. Accordingly, the Board of Appeal was right to find that registration of the mark sought was likely to give the public the impression that there was a connection between the mark sought and the institutions in question.</p>
-----------	--

4 Check whether registration has been authorised

Where there is no evidence that registration of the mark applied for has been authorised, the examiner will object to its registration. The objection must reproduce the protected symbol, quoting its *6ter* number.

The examiner must also indicate the refused goods and services clearly and give reasons why the mark suggests to the public a connection with the organisation concerned.

Such an objection can only be waived if the applicant provides evidence that the competent authority has authorised registration of the mark.

Extent of the refusal: In the case of flags and symbols of international intergovernmental organisations, the refusal must specify the goods and / or services affected, that is, those in respect of which the public would, according to the examiner, see a connection between the mark and an organisation.

2.9.3 Protection of badges, emblems or escutcheons other than those covered by Article *6ter* of the Paris Convention under Article 7(1)(i) CTMR

In accordance with Article 7(1)(i) CTMR, trade marks will not be registered if they include badges, emblems or escutcheons other than those that are covered by Article *6ter* of the Paris Convention and are of particular public interest, unless the competent authority has consented to their registration.

As seen above, Article 7(1)(i) CTMR refers to all other badges, emblems or escutcheons that have not been communicated in accordance with Article *6ter*(3)(a) PC regardless of whether they are the emblems of a state or international intergovernmental organisation within the meaning of Article *6ter*(1)(a) or (b) PC or of public bodies or administrations other than those covered by Article *6ter* PC, such as provinces or municipalities.

Furthermore, according to the case-law, Article 7(1)(i) and Article 7(1)(h) CTMR both have a similar scope of application and grant at least equivalent levels of protection.

This means that Article 7(1)(i) CTMR applies not only where the abovementioned symbols are reproduced identically as a trade mark or a part thereof, but also where the mark consists of or contains a heraldic imitation of those symbols. Any other interpretation of this provision would result in less protection being provided by Article 7(1)(i) CTMR than by Article 7(1)(h) CTMR. Following the same line of reasoning, Article 7(1)(i) CTMR applies where the mark is liable to mislead the public as to the existence of a connection between the owner of the trade mark and the body to which the abovementioned symbols refer. In other words, the protection afforded by Article 7(1)(i) CTMR is conditional on a link between the mark and the symbol. Otherwise, trade marks to which Article 7(1)(i) CTMR applies, would obtain broader protection than under Article 7(1)(h) CTMR (see judgment of 10/07/2013, Case T-3/12 'MEMBER OF EURO EXPERTS').

Article 7(1)(i) does not define symbols of 'particular public interest'. However, it is reasonable to assume that the nature of these could vary and could include, for example, religious symbols, political symbols or symbols of public bodies or administrations other than those covered by Article 6ter PC, such as provinces or municipalities. In any case, the 'particular public interest' involved must be reflected in a public document, for example a national or international legal instrument, regulation or other normative act.

The General Court stated that a 'particular public interest' existed when the emblem had a particular link with one of the activities carried out by an international intergovernmental organisation (see judgment of 10/07/2013, Case T-3/12, 'MEMBER OF EURO EXPERTS', para.44). In particular, the Court specified that Article 7(1)(i) CTMR applied also when the emblem merely evoked one of the fields of activity of the European Union, and even if that activity concerned only some of the EU states (see *ibidem*, paras 45 and 46).

This confirms that the protection afforded by Article 7(1)(i) CTMR applies also to symbols that are of particular public interest in only a single Member State or part thereof (Article 7(2) CTMR).

There are four steps to examining marks that contain badges, emblems and escutcheons of particular public interest.

- 1 Find the symbol of particular public interest.
- 2 Compare the symbol with the mark applied for.
- 3 Check whether the mark applied for suggests to the relevant public that there is a connection between the owner and the authority to which the symbol refers or misleads the public as to the existence of such a connection.
- 4 Check whether there is any evidence on file to show that registration has been authorised by the appropriate authority.

- 1 Find the symbol of particular public interest

At present, there is no list or database allowing examiners to identify which symbols are of particular public interest, especially in a Member State or part thereof. Therefore,

third party observations are likely to remain the source of many objections to such symbols.

One example of a symbol of particular public interest is the Red Cross, which is protected by the Convention for the Amelioration of the Condition of the Wounded and Sick in Armed Forces in the Field, signed in Geneva (<http://www.icrc.org/> and <http://www.icrc.org/Web/Eng/siteeng0.nsf/htmlall/genevaconventions>).

The following symbols are protected under the Geneva Convention:



Apart from the symbols, their names are also protected (from left to right) as follows: 'Red Cross', 'Red Crescent' and 'Red Crystal'.

Another example of a symbol of particular public interest is the Olympic symbol as defined in the Nairobi Treaty on the Protection of the Olympic Symbol. According to the definition in the Nairobi Treaty, 'the Olympic symbol consists of five interlaced rings: blue, yellow, black, green and red, arranged in that order from left to right. It consists of the Olympic rings alone, whether delineated in a single color or in different colors.'



The following symbol was considered not to be a symbol of particular public interest:

RESPONSIBLE RECYCLING PACKAGING

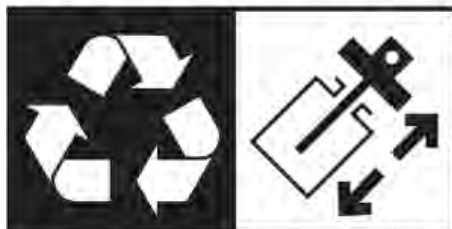

SEPARATE GLASS FROM PLASTIC

The recycling symbol (on the left) was not considered to be protected under this provision because it is a commercial symbol.



2 Compare the symbol with the mark applied for

Does the mark applied for consist solely of or contain an identical reproduction of the symbol of particular public interest? Or does the mark applied for consist of or contain a heraldic imitation thereof?



- (a) Does the mark applied for consist solely of or contain an identical reproduction of the symbol? If so, proceed to the next step.
- (b) Does the mark applied for consist solely of or contain a heraldic imitation of the symbol?

The test is the same as the one for flags and symbols of international intergovernmental organisations, that is, the symbol and the mark (or the part of the mark in which the symbol is reproduced) must be quite similar.

The following are examples of marks that were rejected because they contained the Red Cross symbol or a heraldic imitation thereof.

Refused CTMAs		
		
WO 964 979	CTMA 2 966 265	CTMA 5 988 985



On the other hand, a number of well-known red crosses have traditionally been used and are still in use, the incorporation of which in a mark would not be considered a reproduction of the 'Red Cross'. Examples of these famous crosses include the following:

		
Templar cross	St George's cross	Maltese cross

The following CTM was accepted because it contained two reproductions of the Templar cross.



A mark which contains a cross in black and white (or shades of grey) is not objectionable. Nor is a cross in a colour other than red objectionable under Article 7(1)(i) CTMR.

Accepted CTMAs		
		
CTMA 8 986 069	CTMA 9 019 647	CTMA 9 025 768

- 3 Check whether the mark applied for suggests to the relevant public that there is a connection between the owner and the authority to which the symbol refers or misleads the public as to the existence of such a connection.

A connection is suggested not only where the public would believe that the goods or services originate with the authority in question, but also where the public could believe that the goods or services have the approval or warranty of, or are otherwise linked to, that authority (see GC judgment of 10/07/2013, Case T-3/12 'MEMBER OF EURO EXPERTS', para. 78).

In order to assess the circumstances properly, the examiner must, as above, take into account the following:

- the goods and/or services covered by the CTM application;
- the relevant public;
- the overall impression conveyed by the mark.

The examiner must evaluate whether there is any overlap between the claimed goods and / or services and the activities of the authority at issue and whether the relevant public could be aware of it.

In particular, with regard to the European Union, the examiner must take into account that the latter is active in numerous fields, as is clear from the wide variety of Directives that it has adopted.

Furthermore, the examiner must also take into account the other elements of which the mark is composed. For it cannot be ruled out that all the other elements of the sign could lead to the conclusion that the public would not connect the sign with the authority concerned (see GC judgment of 10/07/2013, Case T-3/12 'MEMBER OF EURO EXPERTS', para. 107).

Still with regard to the EU, it must be noted that, as a rule, word elements such as 'EURO'/'EUROPEAN' in a CTMA are likely to suggest a connection even more, since they could be perceived as implying EU approval (see GC judgment of 10/07/2013, Case T-3/12 'MEMBER OF EURO EXPERTS', para. 113).

For example, the General Court (in Case T-3/12) confirmed that the following mark (CTMA No 6 110 423, covering Classes 9, 16, 35, 36, 39, 41, 42, 44 and 45)



fell foul of Article 7(1)(i) CTMR since it contained a (heraldic) imitation of the 'Euro' symbol.



4 Check whether registration has been authorised

Is there any evidence on file that the appropriate authority has authorised registration?

Where there is no such evidence, the examiner will object to the registration of the mark applied for. The objection will reproduce the symbol and provide the applicant with all necessary details and, in particular, information on why the symbol is of 'particular public interest' (for example, if protected by an international instrument, a reference to that instrument; in the case of the Red Cross this is the Convention for the Amelioration of the Condition of the Wounded and Sick in Armed Forces in the

Field, signed in Geneva (<http://www.icrc.org/> and <http://www.icrc.org/Web/Eng/siteeng0.nsf/htmlall/genevaconventions>)).

Such an objection can only be waived if the applicant submits evidence that the appropriate authority has consented to registration of the mark.

Extent of the refusal: In the case of symbols of particular public interest, the refusal must specify the goods and / or services affected, that is, those in respect of which the public would, according to the examiner, see a connection between the mark and the authority.

2.10 Article 7(1)(j) CTMR

2.10.1 Introduction

Article 7(1)(j) CTMR applies to CTMs that are in conflict with geographical indications for wines and spirits.

More specifically, it provides for the refusal of CTMs for wines that contain or consist of a geographical indication identifying wines or for spirits that contain or consist of a geographical indication identifying spirits in respect of wines or spirits not of such origin.

Article 7(1)(j) CTMR does not explicitly refer to the specific EU regulations on the protection of geographical indications for wines and spirits. In this respect, the Office follows a systematic approach and interprets Article 7(1)(j) CTMR in line with Article 7(1)(k) CTMR. That is to say, the Office applies Article 7(1)(j) CTMR in conjunction with the relevant provisions of the EU regulations on the protection of geographical indications for wines and spirits, namely Council Regulation (EU) No 1308/2013³ and Regulation (EC) No 110/2008 of the European Parliament and of the Council⁴ respectively.

According to Article 93 of Regulation (EU) No 1308/2013:

- (a) 'designation of origin' means the name of a region, a specific place or, in exceptional cases, a country used to describe a wine that complies with the following requirements:
- (i) its quality and characteristics are essentially or exclusively due to a particular geographical environment with its inherent natural and human factors;
 - (ii) the grapes from which it is produced come exclusively from this geographical area;
 - (iii) its production takes place in this geographical area; and
 - (iv) it is obtained from vine varieties belonging to *Vitis vinifera*;

³ Council Regulation (EU) No 1308/2013 of 17 December 2013 establishing a common organisation of the markets in agricultural products.

⁴ Regulation (EC) No 110/2008 of the European Parliament and of the Council of 15 January 2008 on the definition, description, presentation, labelling and the protection of geographical indications of spirit drinks and repealing Council Regulation (EEC) No 1576/89.

- (b) 'geographical indication' means an indication referring to a region, a specific place or, in exceptional cases, a country, used to describe a wine that complies with the following requirements:
- (i) it possesses a specific quality, reputation or other characteristics attributable to that geographical origin;
 - (ii) at least 85 % of the grapes used for its production come exclusively from this geographical area;
 - (iii) its production takes place in this geographical area; and
 - (iv) it is obtained from vine varieties belonging to *Vitis vinifera* or a cross between the *Vitis vinifera* species and other species of the genus *Vitis*.

According to Article 15(1) of Regulation (EC) No 110/2008, a 'geographical indication' is an indication that identifies a spirit drink as originating in the territory of a country, or a region or locality in that territory, where a given quality, reputation or other characteristic of that spirit drink is essentially attributable to its geographical origin.

Protected designations of origin (PDOs) therefore have a closer link with the area. This distinction, however, does not affect scope of protection, which is the same for PDOs and PGIs (protected geographical indications). In other words, Article 7(1)(j) CTMR applies equally to all designations covered by Regulation (EU) No 1308/2013, regardless of whether they are registered as PDOs or as PGIs. Regulation No 110/2008, however, covers only PGIs, not PDOs.

Protection is granted to PDOs/PGIs in order, inter alia, to protect the legitimate interests of consumers and producers.

In this respect, it must also be underlined that the concepts of PDO and PGI differ from a 'simple indication of geographical provenance'. For the latter, there is no direct link between a specific quality, reputation or other characteristic of the product and its specific geographical origin, with the result that it does not come within the scope of Article 93 of Regulation (EU) No 1308/2013 or Article 15(1) of Regulation (EC) No 110/2008 (see, by analogy, judgment of 07/11/2000, C-312/98, 'Warsteiner Brauerei', paras 43 and 44). For example, 'Rioja' is a PDO for wines since it designates a wine with particular characteristics that comply with the definition of a PDO. However, wine produced in 'Tabarca' (a 'simple geographical indication' designating a small island close to Alicante) cannot qualify for a PDO/PGI unless it meets specific requirements.

According to Article 102(1) of Regulation (EU) No 1308/2013, the registration of a trade mark that contains or consists of a protected designation of origin or a geographical indication which does not comply with the product specification concerned or the use of which falls under Article 103(2), and that relates to a product falling under one of the categories listed in Part II of Annex VII shall be refused if the application for registration of the trade mark is submitted after the date of submission of the application for protection of the designation of origin or geographical indication to the Commission and the designation of origin or geographical indication is subsequently protected.

Furthermore, according to Article 23(1) of Regulation (EC) No 110/2008, 'the registration of a trade mark which contains or consists of a geographical indication registered in Annex III shall be refused or invalidated if its use would lead to any of the situations referred to in Article 16'.

Article 103(2) of Regulation (EU) No 1308/2013 and Article 16 of Regulation (EC) No 110/2008 set out the situations that infringe the rights deriving from a PDO/PGI: (i) direct or indirect commercial use of the PDO/PGI; (ii) misuse, imitation or evocation; (iii) other misleading practices.

Three cumulative conditions are necessary in order for Article 7(1)(j) CTMR to apply.

1. The PDO/PGI in question must be registered at EU level (see paragraph 2.9.2.1 below).
2. Use of the CTM that consists of or contains a PDO/PGI for wines or a PGI for spirits must constitute one of the situations provided for in Article 103(2) of Regulation (EU) No 1308/2013 or in Article 16 of Regulation (EC) No 110/2008 (see paragraph 2.9.2.2 below).
3. The CTM application must include goods that are identical or 'comparable' to the goods covered by the PDO/PGI (see paragraph 2.9.2.3 below).

For these three conditions, reference is made below to: (i) which PDOs/PGIs may give rise to an objection under Article 7(1)(j) CTMR; (ii) under what circumstances a CTM contains or consists of a PDO/PGI in such a way that it falls under Article 103(2) of Regulation (EU) No 1308/2013 or Article 16 of Regulation (EC) No 110/2008; (iii) the goods of the CTM application affected by the protection granted to the PDO/PGI. Finally, reference is also made below to how goods can be restricted in order to waive an objection.

2.10.2 The application of Article 7(1)(j) CTMR

2.10.2.1 Relevant PDOs/PGIs

Article 7(1)(j) CTMR applies where PDOs/PGIs (either from an EU Member State or from a third country) have been registered under the procedure laid down by Regulations No 1308/2013 and No 110/2008.

For third-country PDOs/PGIs that enjoy protection in the European Union through international agreements concluded between the European Union and third countries see paragraph 2.9.3.2 below.

Relevant information about PDOs/PGIs for wines can be found in the 'E-Bacchus' database maintained by the Commission, which can be accessed through the internet at <http://ec.europa.eu/agriculture/markets/wine/e-bacchus/>. PGI's for spirit drinks are listed in Annex III of Regulation No 110/2008 (Article 15(2) of Regulation No 110/2008), as amended, which can be accessed at <http://eur-lex.europa.eu/legal-content/EN/TXT/PDF/?uri=CELEX:32012R0164&from=EN>. The Commission also maintains a database, 'E-Spirit-Drinks', accessible at <http://ec.europa.eu/agriculture/spirits/>. However, this is not an official register and is, therefore, only informative in character.

Protection is granted solely to the name of a PDO/PGI and does not extend *ipso iure* to the names of sub-regions, sub-denominations, local administrative areas or localities in the area covered by that PDO/PGI. In this respect, a distinction must be made between the doctrine of the General Court in judgment of 11/05/2010, T-237/08, 'Cuvée Palomar' and the current legal framework. That judgment refers to a system of Member

State competencies on the designation of geographical indications for wines that existed under previous Regulation (EC) No 1493/1999 but is no longer in force. According to Article 67 of Commission Regulation (EC) No 607/2009 (see also Article 120(1)(g) of Regulation (EU) No 1308/2013) the names of those small geographical areas are now considered merely optional particulars on labels.

On the other hand, the trade agreements signed by the EU with third countries typically have annexed to them a list of the PDOs/PGIs registered at EU level that are also to be protected in the third countries in question (see judgment of 11/05/2010, T-237/08, 'Cuvée Palomar', paras 104-108 and decision of 19/06/2013, R 1546/2011-4 – 'FONT DE LA FIGUERA'). However, examiners should not use those lists as a source of information about EU PDOs/PGIs but should refer to the corresponding databases cited above. Firstly, the lists of EU PDOs/PGIs to be protected abroad may vary from one agreement to another, depending on the particularities of the negotiations. Secondly, the annexes to the agreements are usually amended and updated through an 'Exchange of Letters'.

Article 7(1)(j) CTMR applies only in respect of PDOs/PGIs that were applied for before the CTM **and** are registered at the time of examining the CTM. The relevant dates for establishing the priority of a trade mark and of a PDO/PGI are the date of application of the CTM (or the so-called Paris Convention priority, if claimed) and the date of application for protection of a PDO/PGI to the Commission respectively.

Therefore, **no objection will be raised** under Article 7(1)(j) CTMR when the PDO/PGI was applied for **after** the filing date (or priority date, if applicable) of the CTM application. For wines, where there is no relevant date information in the 'E-Bacchus' extract, this means that the PDO/PGI in question was already in existence on 01/08/2009, the date on which the register was set up. For any PDOs/PGIs for wines added subsequently, the 'E-Bacchus' extract includes a reference to the publication in the Official Journal, which gives the relevant information. For spirit drinks, the initial publication of Annex III of Regulation (EC) No 110/2008 contained all PGIs for spirit drinks that existed on 20/02/2008, the date of entry into force of that regulation. For any PGIs for spirit drinks added subsequently, the corresponding amendment regulation contains the relevant information;

Notwithstanding the above, and in view of the fact that the vast majority of applications for PDO/PGI usually mature in a registration, **an objection will be raised** when the PDO/PGI was applied for **before** the filing date (or the priority date, if applicable) of the CTM application **but** had not yet been registered at the time of examining the CTM application. However, if the CTM applicant submits that the PDO/PGI in question has not yet been registered, the proceedings will be suspended until the outcome of the registration procedure of the PDO/PGI.

2.10.2.2 Situations covered by Article 103 of Regulation (EU) No 1308/2013 and Article 16 of Regulation (EC) No 110/2008

Article 7(1)(j) CTMR applies (provided that the other conditions also apply) in all of the following situations:

1. the CTM consists solely of a whole PDO/PGI ('direct use');
2. the CTM contains a whole PDO/PGI in addition to other word or figurative elements ('direct or indirect use');

3. the CTM contains or consists of an imitation or evocation of a PDO/PGI;
4. other misleading indications and practices;
5. the reputation of PDOs/PGIs.

CTM consists solely of a whole PDO/PGI ('direct use')

This situation covers the 'direct use' of a PDO/PGI as a CTM, that is, the trade mark consists solely of the name of the PDO/PGI.

Examples

PDO/PGI	Community trade mark
MADEIRA (PDO-PT-A0038)	MADEIRA (Collective CTM No 3 540 911)
MANZANILLA (PDO-ES-A1482)	MANZANILLA (Collective CTM No 1 723 345)

If the mark consists solely of the PDO/PGI, the CTM also falls under Article 7(1)(c) CTMR, since it is considered descriptive of the geographical origin of the goods in question. This means that the examiner's objection will simultaneously raise absolute grounds for refusal under both Article 7(1)(j) and 7(1)(c) CTMR. There is an exception to this, pursuant to Article 66(2) CTMR, when the CTM is a collective trade mark and the regulations governing use thereof include the particulars foreseen in Article 67(2) (for the contrary situation, where the mark had been applied for as an individual mark, see decision of 07/03/2006, R 1073/2005-1 – 'TEQUILA', para. 15).

While restricting the relevant goods (to comply with the specifications of the PDO/PGI) is usually a means of waiving the objection under Article 7(1)(j) CTMR (see paragraph 2.9.2.3 below), such restriction is irrelevant for Article 7(1)(c) CTMR.

For example, an application for the word mark 'Bergerac' for *wines* will simultaneously be objected to under both Article 7(1)(j) and Article 7(1)(c) CTMR: it consists solely of the PDO 'Bergerac' and is therefore descriptive. If the goods are subsequently limited to *wines complying with the specifications of the PDO 'Bergerac'*, the objection under Article 7(1)(j) CTMR will be waived but the trade mark is still descriptive and continues to be objectionable under Article 7(1)(c) CTMR, unless it has been applied for as a collective trade mark that complies with Article 67(2) CTMR.

CTM contains a whole PDO/PGI in addition to other word or figurative elements ('direct or indirect use')

This situation also covers the 'direct use' of a PDO/PGI in a CTM through reproduction of the name of the PDO/PGI together with other elements.

The following CTMs are considered to fall under Article 7(1)(j) CTMR since they contain the whole denomination of a PDO/PGI.

PDO/PGI	Community trade mark
<p>BEAUJOLAIS (PDO-FR-A0934)</p>	<p>BEAUX JOURS BEAUJOLAIS (CTM No 1 503 259)</p>
<p>CHAMPAGNE (PDO-FR-A1359)</p>	<p>CHAMPAGNE VEUVE DEVANLAY (CTM No 11 593 381)</p>
<p>BEAUJOLAIS (PDO-FR-A0934)</p>	 <p><i>• La Maison des Beaujolais •</i> (CTM No 1 561 646)</p>

Under Article 7(1)(j) CTMR it is irrelevant whether or not the other word or figurative elements may give the trade mark distinctive character. The sign can be acceptable as a whole under Article 7(1)(b) and (c) CTMR and still be objectionable (as in the cases above) under Article 7(1)(j) CTMR.

There is 'indirect use' of a PDO/PGI, for example, when the PDO/PGI appears in a complex trade mark (such as the representation of a label) in smaller characters as information about the origin or type of the product or as part of the producer's address. In such cases the trade mark will be objectionable irrespective of the position or the size of the PDO/PGI within the trade mark as a whole, provided that it is visible.

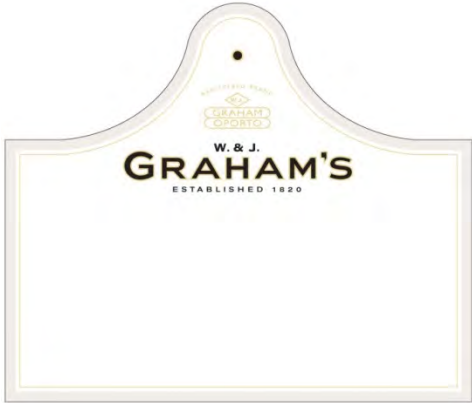
PDO/PGI	Community trade mark
<p>OPORTO (PDO-PT-A1540)</p>	 <p>CTMs No 11 907 334 and No 2 281 970)</p>

CTM contains or consists of an imitation or evocation of a PDO/PGI

Neither the CTMR nor Regulations No 1308/2013 and No 110/2008 define the meaning of 'imitation' or 'evocation'. To a large extent, they are closely related concepts.

According to the Court, 'evocation' covers 'a situation where the term used to designate a product incorporates part of a protected designation, so that when the consumer is confronted with the name of the product, the image triggered in his mind is that of the product whose designation is protected' (judgment of 04/03/1999, C-87/97, 'Cambozola', para. 25 and judgment of 26/02/2008, C-132/05, para. 44).

The above means that there may be evocation when the CTM reproduces **part of** a PDO/PGI, such as (one of its) geographically significant word element(s) (in the sense that it is not a generic element, like 'cabernet' and 'ron' in the PDO/PGI 'Cabernet d'Anjou' or 'Ron de Granada'), or even part of a word, such as a characteristic root or ending (examples are given below).

Moreover, Article 103(2)(b) of Regulation (EU) No 1308/2013 and Article 16 of Regulation (EC) No 110/2008 protect PDOs/PGIs against misuse, imitation or evocation, 'even if the true origin of the product is indicated or if the protected name is translated or accompanied by an expression such as "style", "type", "method", "as produced in", "imitation" ... or similar', thus even if consumers are not misled.

According to the Advocate General (opinion of 17/12/1998, C-87/97, 'Cambozola', para. 33), 'the term "evocation" is objective, so that it is not necessary to show that the owner of the mark intended to evoke the protected name'.

In this respect, and for the purposes of Article 7(1)(j) CTMR, the Office will assess in an equally objective way the situations described below, regardless of the CTM applicant's actual intention.

Furthermore, the Office considers the terms 'imitation' and 'evocation' as two corollaries of essentially the same concept. The mark 'imitates' (mimics, reproduces elements of, etc.), with the result that the product designated by the PDO/PGI is 'evoked' (called to mind).

In the light of the above, the Office finds that there is evocation or imitation of a PDO where:

- (a) the CTM incorporates the geographically significant part (in the sense that it is not the generic element) of the PDO/PGI;
- (b) the CTM contains an equivalent adjective/noun that indicates the same geographical origin;
- (c) the PDO/PGI is translated;
- (d) the CTM includes a 'de-localizer' expression in addition to the PDO/PGI or its evocation.

The CTM incorporates part of the PDO/PGI

According to the Court (judgment of 04/03/1999, C-87/97, 'Cambozola', and judgment of 26/02/2008, C-132/05, cited above), the CTM must trigger in the consumer's mind the image of the product whose designation is protected.

The Court has also stated that ‘it is possible ... for a protected designation to be evoked where there is no likelihood of confusion between the products concerned’ (judgment of 04/03/1999, C-87/97, ‘Cambozola’, para. 26).

Importantly, evocation is not assessed in the same way as likelihood of confusion (see opinion of the Advocate General of 17/12/1998, C-87/97, ‘Cambozola’, para. 37). A link must be made **with the product** whose designation is protected. Therefore, whether or not there is evocation will not be analysed according to the principles laid down by the CJEU in judgment of 11/11/1997, C-251/95, ‘Sabèl’.

As pointed out above, evocation is understood as encompassing not only when the CTM incorporates (one of) the geographically significant word(s) (as opposed to generic) element(s) of a PDO/PGI, but also when the CTM reproduces other parts of that PDO/PGI, such as a characteristic root or ending.

Although the following examples concern foodstuffs, they equally serve to demonstrate ‘imitation’ and ‘evocation’ for wines and spirit drinks.

PDO/PGI	Trade Mark	Explanation
<p>CHIANTI CLASSICO (IT/PDO/0005/0108)</p>	 <p>(CTM 9 567 851)</p>	<p>The term ‘chianti’ evokes the PDO ‘Chianti Classico’. (R 1474/2011-2, ‘AZIENDA OLEARIA CHIANTI’, paras 14-15)</p>
<p>GORGONZOLA (IT/PDO/0017/0010)</p>	<p>CAMBOZOLA</p>	<p>‘... a protected name is indeed evoked where the term used to designate that product ends in the same two syllables and contains the same number of syllables, with the result that the phonetic and visual similarity between the two names is obvious’ (C-87/97, para. 27)</p>

If a PDO/PGI contains or evokes the name of a product that is considered generic, protection does not extend to the generic element. For example, in the PGI ‘Ron de Málaga’, it is a well-known fact that the term ‘ron’ (rum in Spanish) is generic and therefore does not deserve protection. Accordingly, no objection will be raised to the mere fact that a CTM contains a generic term that is part of a PDO/PGI.

Where the generic nature of an element in a PDO/PGI can be determined by standard dictionary definitions, the perspective of the public in the country of origin of the PDO/PGI is determinative. For instance, in the examples cited above, it suffices that the term ‘ron’ is generic for Spanish consumers for it to be concluded that it is generic, regardless of whether or not it can be understood by other parts of the public in the European Union.

By contrast, where no definition can be found in a standard, well-known dictionary, the generic nature of the term in question should be assessed following the criteria laid

down by the Court (see judgment of 26/02/2008, C-132/05 and judgment of 12/09/2007, T-291/03, ‘Grana Biraghi’), such as relevant national and EU legislation, how the term is perceived by the public, and circumstances relating to the marketing of the product in question.

Finally, in some cases a CTM may constitute direct/indirect use or evocation of more than one PDO/PGI at the same time. This is likely to happen when the CTM contains an element (not being a generic one) that appears in more than one PDO/PGI.

PDO/PGI	RIOJA (PDO-ES-A0117) SANTIAGO (Chilean PGI)
Community trade mark	RIOJA SANTIAGO
Explanation	<p>The trade mark applied for consists of the terms ‘RIOJA’ and ‘SANTIAGO’, each of which coincides with a protected designation of origin for wines, the former (‘RIOJA’) being protected by the European Union and the latter (‘SANTIAGO’), a geographical indication for a wine originating from Chile, being protected under a bilateral agreement between the European Union and the Republic of Chile (...)</p> <p>It is not possible to accept any limitation that includes ‘wine’ originating from the territory of one of the two designations of origin since such a limitation automatically excludes wines originating from the other designation of origin, which inevitably means that the trade mark applied for will lead to confusion. By the same token, a hypothetical limitation of the list of goods to wine from the geographical area covered by either of the designations of origin, e.g. ‘wines from the Rioja designation of origin and wines from the Santiago designation of origin’, in Class 33, would be covered by the prohibition of Article 7(1)(j) CTMR insofar as the trade mark would inevitably – and confusingly – identify wines with a geographical origin other than that of the respective designations of origin included under the trade mark. Preventing such an eventuality is the principal purpose of that Article.</p> <p>(R 0053/2010-2, ‘RIOJA SANTIAGO’)</p>

Provided that the CTM covers the relevant goods, an objection should be raised in respect of all the PDOs/PGIs concerned. However, the examiner will indicate that the objection cannot be overcome, because limiting the goods to those that comply with either one of or all of the PDOs/PGIs would necessarily trigger another objection under Article 7(1)(j) CTMR since such a limitation would inevitably and confusingly identify wines with a geographical origin other than that of the PDO/PGI in question.

Equivalent adjectives/nouns

The use of an equivalent adjective/noun to indicate the same origin constitutes an evocation of a PDO/PGI.

PDO/PGI	Community trade mark (invented examples)	Explanation
IBIZA (PGI-ES-A0110)	IBICENCO	Noun in the PDO → Adjective in the CTM
AÇORES	AÇORIANO	Noun in the PDO → Adjective in the CTM

(PGI-PT-A1447)		
BORDEAUX (PDO-FR-A0821)	BORDELAIS	Noun in the PDO → Adjective in the CTM

Translated PDOs/PGIs

Likewise, there is evocation or imitation of the PDO/PGI when the CTM contains or consists of a translation of the whole or part of a PDO/PGI in any of the EU languages.

PDO/PGI	Community trade mark	Explanation
COGNAC	KONJAKKI (invented example)	A CTM that contains the term 'Konjakki' will be considered to evoke 'Cognac' in Finnish.
BOURGOGNE	 CTM 2417269	'Borgoña' is the Spanish translation of the French PDO 'Bourgogne'

Trade marks consisting of these terms must be refused under both Article 7(1)(j) and 7(1)(c) CTMR rather than solely under Article 7(1)(c) CTMR.

Expressions used as 'de-localisers'

According to Article 103(2)(b) of Regulation (EU) No 1308/2013 and Article 16(b) of Regulation (EC) No 110/2008, PDOs/PGIs are protected 'even if the true origin of the product ... is indicated or if the protected name is ... accompanied by an expression such as "style", "type", "method", "as produced in", "imitation" ... or similar'.

Therefore, the fact that the PDO/PGI reproduced or evoked in the CTM is accompanied by these expressions does not militate against the application of Article 7(1)(j) CTMR. In other words, even if the public is thereby informed about the actual origin of the product, an objection will still be raised under Article 7(1)(j) CTMR. Notwithstanding this, the trade mark will be misleading under Article 7(1)(g) CTMR since there is a contradiction between the goods (restricted to the specific PDO/PGI) and the message conveyed by the mark (that the goods are not 'genuine' PDO/PGI products), which will thus necessarily lead to a further objection under that Article.

PDO/PGI	Community trade mark (invented examples)	Explanation
RIOJA (PDO-ES-A0117)	RIOJA STYLE RED WINE	A CTM that contains an expression such as 'Rioja Style Red Wine' will be considered to evoke the PDO 'Rioja' even if it conveys the idea that the product in question is not a 'genuine' PDO Rioja wine.

Where the applicant has its legal seat is irrelevant for assessing Article 7(1)(j) CTMR. Article 103(1) of Regulation (EU) No 1308/2013 sets out that protected designations of origin and protected geographical indications may be used by any operator marketing a product that conforms to the corresponding specification. Hence, provided that the goods comply with the specification of the PDO/PGI in question (which is guaranteed by restricting the goods appropriately), the location of the applicant's legal seat as indicated in the CTM application is irrelevant. For example, a company with legal domicile in Poland can own a vineyard located in Spain that produces wine complying with the product specification of the PDO 'Ribera del Duero'.

Other misleading indications and practices

Article 103(2)(c) and (d) of Regulation (EU) No 1308/2013 and Article 16(c) and (d) of Regulation (EC) No 110/2008 protect the PDO/PGI against a number of false or misleading indications about the origin, nature or essential qualities of the product.

Although it very much depends on the particularities of each case, each of which must therefore be assessed individually, a CTM may be considered misleading when, for example, it contains figurative elements that are typically associated with the geographical area in question (such as well-known historical monuments).

The above must be interpreted in a restrictive way: it refers solely to CTMs that depict a well-known and singular image that is generally taken as a symbol of the particular place of origin of the products covered by the PDO/PGI.

PDO/PGI	Community trade mark (invented examples)	Explanation
<p style="text-align: center;">PORTO (PDO-PT-A1540)</p>	<p style="text-align: center;">CTM depicting the 'Dom Luís I Bridge' in the city of Porto</p>	<p>A picture of the Dom Luís I Bridge and its riverside is a well-known emblem of the city of Porto. Use of this image for wines other than those covered by the PDO 'Porto' would fall under Article 103(2)(c) and (d) of Regulation (EU) No 1308/2013.</p>

Given the inherent difficulty in identifying evocative figurative elements, particularly in less obvious cases, the Office will in such cases rely principally on objections by third parties.

The reputation of PDOs/PGIs

According to Article 103(2)(a) of Regulation (EU) No 1308/2013 and Article 16(a) of Regulation (EC) No 110/2008, registered names are protected against use that exploits the reputation of the protected name. This protection extends even to different products (see by analogy judgment of 12/06/2007, joined cases T-53/04 to T-56/04, T-58/04 and T-59/04, 'Budweiser', para. 176).

However, the scope of such protection must be read in line with the mandate contained in Article 102 of Regulation (EU) No 1308/2013, which limits the refusal of trade marks to products listed in its Annex VII, Part II.

Therefore, the Office considers that, in the context of examining absolute grounds for refusal, the PDO/PGI's protection is limited to identical or comparable products.

However, the extended scope of protection of a PDO/PGI with reputation can be invoked in the context of Article 8(4) CTMR (see the Guidelines, Part C, Opposition, Section 4, Rights Under Article 8(4) CTMR).

2.10.2.3 Relevant goods

Comparable products

Objections based on Article 7(1)(j) CTMR can be raised only in respect of specific goods of the CTM application, namely those that are identical or 'comparable' to ones covered by the PDO/PGI.

The different terms used in Articles 102(1) and 103(2) of Regulation (EU) No 1308/2013 ('product falling under one of the categories listed in Part II of Annex VII' and 'comparable products' respectively) are interpreted by the Office as synonyms referring to the same concept.

For ease of reference, the categories listed in Part II of Annex VII can be grouped in: (i) wine; (ii) sparkling wine; (iii) grape must; (iv) wine vinegar.

The notion of **comparable goods** must be understood restrictively and it is independent of the analysis of similarity between goods in trade mark law. Accordingly, the criteria set out in judgment of 29/09/1998, C-39/97, 'Canon', should not necessarily be adhered to, although some of them may be useful. For example, given that a PDO/PGI serves to indicate the geographical origin and the particular qualities of a product, criteria such as the nature of the product or its composition are more relevant than, for instance, whether or not goods are complementary.

In particular, the CJEU (in judgment of 14/07/2011, joined cases C-4/10 and C-27/10, 'BNI Cognac', para. 54) has listed the following criteria for determining whether goods are comparable:

- whether or not they have common objective characteristics (such as method of elaboration, physical appearance of the product or use of the same raw materials);
- whether or not they are consumed, from the point of view of the relevant public, on largely identical occasions;
- whether or not they are distributed through the same channels and subject to similar marketing rules.

Although it is not possible in these Guidelines to list all the possible scenarios, the following are some examples of comparable products.

Products covered by the PDO/PGI	Comparable products
Wine	All types of wines (including sparkling wine); grape must; wine vinegar; wine-based beverages (e.g. 'sangría')
Spirits	All types of spirits; spirit-based drinks

Restrictions of the list of goods

According to Article 103(1) of Regulation (EU) No 1308/2013, protected designations of origin and protected geographical indications may be used by any operator marketing a wine conforming to the corresponding specification.

Objections raised under Article 7(1)(j) CTMR may be waived if the relevant goods are restricted to comply with the specifications of the PDO/PGI in question.

Restriction of goods can be a complex task, which may depend to a large extent on a case-by-case examination.

- **Products of the same type** as those covered by the PDO/PGI must be restricted in order to meet the specifications of the PDO/PGI. The proper wording is '*[name of the product] complying with the specifications of the [PDO/PGI 'X']*'. No other wording should be proposed or allowed. Restrictions such as '*[name of the product] with the [PDO/PGI 'X']*' or '*[name of the product] originating in [name of a place]*' are not acceptable.

PDO/PGI in the Community trade mark	Acceptable list of goods
Slovácká (PDO-CZ-A0890)	Wine complying with the specifications of the PDO 'Slovácká'

- The **category of products** that includes those covered by the PDO/PGI should be restricted to designate 'wines' that comply with the specifications of the PDO/PGI. For spirit drinks, the restriction should designate the exact category of product (e.g. 'whisky', 'rum', 'fruit spirit', in accordance with Annex III of Regulation (EC) No 110/2008) that complies with the specifications of the PDO/PGI.

PDO/PGI in the Community trade mark	Original specification (not acceptable)	Acceptable list of goods	Explanation
TOKAJI (PDO-HU-A1254)	Wines	Wine complying with the specifications of the PDO 'Tokaji'	The CTM can be accepted only for wine covered by the PDO

- **Comparable products** are restricted to those products, within the category of comparable products, covered by the PDO/PGI.

PDO/PGI in the Community trade mark	Original specification (not acceptable)	Acceptable list of goods	Explanation
<p>MOSLAVINA (PDO-HR-A1653)</p>	<p>Alcoholic beverages (except beers)</p>	<p>Wine complying with the specifications of the PDO 'Moslavina'; alcoholic beverages other than wines</p>	<p>The CTM can be accepted only for wine covered by the PDO, and for alcoholic beverages other than wines.</p>

There may be cases where the objection cannot be overcome by a limitation, for example when the goods applied for, although 'comparable', do not include the product covered by the PDO/PGI (e.g. where the PGI covers 'whisky' and the goods applied for are 'rum').

2.10.3 PDOs/PGIs not protected under Regulations (EC) No 1308/2013 and No 110/2008

2.10.3.1 PDOs/PGIs protected at national level in an EU Member State

The Court of Justice has set out (judgment of 08/09/2009, C-478/07, 'Bud') that the EU system of protection for PDOs/PGIs for agricultural products and foodstuffs laid down in Regulation (EC) No 510/2006 [then in effect] is 'exhaustive in nature'. The Office applies an analogous approach for PDOs/PGIs for wines and spirits, for the following reasons.

The former protection at national level of geographical indications for wines and spirit drinks that now qualify for a PDO/PGI under Regulation (EU) No 1308/2013 and Regulation (EC) No 110/2008 respectively was discontinued once those geographical indications were registered at EU level (see Article 107 of Regulation (EU) No 1308/2013 and Articles 15(2), 20(1) of Regulation (EC) No 110/2008).

Geographical indications for wines that now qualify for a PDO/PGI under Regulation (EU) No 1308/2013 and in the past enjoyed protection by means of national legislation do not fall within the scope of Article 7(1)(j) CTMR. Accordingly, they do not constitute as such, and for that reason alone, a ground for refusal under Article 7(1)(j) CTMR, unless they have also been registered at EU level. Therefore, if for example a third party argues that a CTM contains or consists of a geographical indication for wines that was registered in the past at national level in an EU Member State, the examiner will check whether such geographical indication is also registered at EU level as a PDO/PGI. If not, the third party observations will be deemed not to raise serious doubts as regards Article 7(1)(j) CTMR.

2.10.3.2 PDOs/PGIs from third countries

The following situations refer to PDOs/PGIs from third countries that are not simultaneously registered at EU level.

The geographical indication is protected only in the country of origin under national legislation

Article 7(1)(j) CTMR does not apply since the third-country geographical indication is not recognised and protected *expressis verbis* under EU legislation. In this respect, note that the provisions of the TRIPs Agreement are not such as to create rights upon which individuals may rely directly before the courts by virtue of EU law (judgment of 14/12/2000, joined cases C-300/98 and C-392/98, para. 44).

Nevertheless, when the CTM contains or consists of one such protected geographical indication, it must also be assessed whether or not the CTM may be considered descriptive and/or deceptive under Article 7(1)(c) and (g) CTMR in accordance with the general rules set out in these Guidelines. For example, where a third party observes that a CTM consists of the term 'Murakami' (invented example), which is a PGI for spirits in accordance with the national legislation of country X, Article 7(1)(j) CTMR will not apply for the reasons set out above, but it must be examined whether or not the CTM will be perceived as a descriptive and/or deceptive sign by the relevant EU consumers.

The geographical indication is protected under an agreement to which the European Union is a contracting party

The EU has signed a number of trade agreements with third countries that protect geographical indications. These instruments typically include a list of the geographical indications, as well as provisions on their conflicts with trade marks. The content and degree of precision may nevertheless vary from one agreement to another. Geographical indications from third countries are protected at EU level after the relevant agreement has entered into force.

In this respect, it is settled case-law that a provision of an agreement entered into by the EU with non-member countries must be regarded as being directly applicable when, in view of the wording, purpose and nature of the agreement, it may be concluded that the provision contains a clear, precise and unconditional obligation that is not subject, in its implementation or effects, to the adoption of any subsequent measure (judgment of 14/12/2000, joined cases C-300/98 and C-392/98, para. 42).

The scope of protection given to these PGIs by third countries is defined through the substantive provisions of the agreement concerned. While the oldest agreements usually contained only general provisions, the 'last generation' of free trade agreements refer to the relationship between trade marks and PGIs in similar terms to Articles 102 and 103 of Regulation (EU) No 1308/2013 (see, for example, Articles 210 and 211 of the 'Trade Agreement between the European Union and its Member States, of the one part, and Colombia and Peru, of the other part', OJ L 354, 21/12/2012).

In the light of this, CTMs that contain or consist of a third-country PDO/PGI that is protected by an agreement to which the EU is a contracting party (and is not simultaneously registered under Regulation (EU) No 1308/2013) are examined, on a case-by-case basis, in accordance with the specific substantive provisions of the agreement in question on the refusal of conflicting trade marks, taking into account the case-law cited above. The mere fact that a PDO/PGI from a third country is protected by those instruments does not automatically imply that a CTM that contains or consists

of the PDO/PGI must be refused: this will depend on the content and scope of the agreement's relevant provisions.

The geographical indication is protected under an international agreement signed only by Member States

Protection of geographical indications under agreements between two Member States is precluded under current EU regulation of PDOs/PGIs (see the doctrine in judgment of 08/09/2009, C-478/07, 'Bud', applied by the Office by analogy for PDOs/PGIs for wines and spirits). Such agreements are redundant and have no legal effect.

As regards international agreements signed exclusively by Member States with third countries (in particular, the Lisbon Agreement for the Protection of Appellations of Provenance and their International Registration), and for the sole purpose of the examination of absolute grounds for refusal, the EU is not a contracting party to these agreements, and they do not impose any obligations on the EU (see, by analogy, judgment of 14/10/1980, 812/79, para. 9).

2.11 Article 7(1)(k) CTMR

2.11.1 Introduction

Article 7(1)(k) CTMR applies to CTMs that are in conflict with protected designations of origin/protected geographical indications (PDOs/PGIs) for agricultural products and foodstuffs registered at EU level.

More specifically, it provides for the refusal of CTMs that contain or consist of a PDO/PGI for agricultural products and foodstuffs that has been registered under Regulation (EU) No 1151/2012⁵, provided that the situation corresponds to one covered in that regulation.

According to Regulation (EU) No 1151/2012, PDOs/PGIs cover products for which there is an intrinsic link between the product or foodstuff characteristics and its geographical origin.

More particularly:

A 'designation of origin' is a name that identifies a product:

1. originating in a specific place, region or, in exceptional cases, a country;
2. whose quality or characteristics are essentially or exclusively due to a particular geographical environment with its inherent natural and human factors; and
3. the production steps of which all take place in the defined geographical area.

A 'geographical indication' is a name that identifies a product:

1. originating in a specific place, region or country;

⁵ Regulation (EU) No 1151/2012 of the European Parliament and of the Council of 21 November 2012 on quality schemes for agricultural products and foodstuffs. It replaced and repealed Regulation (EC) No 510/2006.

2. whose given quality, reputation or other characteristic is essentially attributable to its geographical origin; and
3. of which at least one of the production steps takes place in the defined geographical area.

PDO is the term used to describe foodstuffs that are produced, processed and prepared in a given geographical area using recognised know-how. A PGI indicates a link with the area in at least one of the stages of production, processing or preparation. PDOs therefore have a stronger link with the area.

This distinction, however, does not affect the scope of protection, which is the same for both PDOs and PGIs. In other words, Article 7(1)(k) CTMR applies indiscriminately to the designations covered by Regulation (EU) No 1151/2012, regardless of whether they are registered as PDOs or as PGIs.

Protection is granted to PDOs/PGIs with the aim of ensuring that they are used fairly and in order to prevent practices liable to mislead consumers (see Recital 29 of Regulation (EU) No 1151/2012).

In this respect, it must also be underlined that the concepts of PDO and PGI differ from 'simple indications of geographical provenance'. For the latter, there is no direct link between a specific quality, reputation or other characteristic of the product and its specific geographical origin, with the result that it does not come within the scope of Article 5(2) of Regulation (EU) No 1151/2012 (judgment of 07/11/2000, C-312/98 'Haus Cramer', paras 43 and 44). For example, 'Queso Manchego' is a PDO for cheese since it designates a product with particular characteristics that comply with the definition of a PDO. However, 'Queso de Alicante' (a 'simple geographical indication') cannot qualify for a PDO/PGI since it does not enjoy such characteristics and requirements.

According to Article 14(1) of Regulation (EU) No 1151/2012,

where a designation of origin or a geographical indication is registered under this Regulation, the registration of a trade mark the use of which would contravene Article 13(1) and which relates to a product of the same type shall be refused if the application for registration of the trade mark is submitted after the date of submission of the registration application in respect of the designation of origin or the geographical indication to the Commission.

Article 13(1) of Regulation (EU) No 1151/2012 sets out the situations that infringe the rights deriving from a PDO/PGI: (i) direct or indirect commercial use of the PDO/PGI; (ii) misuse, imitation or evocation; (iii) false or misleading practices in the packaging or information on the product and (iv) other misleading practices.

Three cumulative conditions are necessary in order for Article 7(1)(k) CTMR to apply:

- The PDO/PGI in question must be registered at EU level under the procedure laid down in Regulation (EU) No 1151/2012 (see paragraph 2.10.2.1 below);
- Use of the CTM that consists of or contains a PDO/PGI for agricultural products and foodstuffs must constitute one of the situations provided for in Article 13(1) of Regulation (EU) No 1151/2012 (see paragraph 2.10.2.2 below);

- The CTM application must include goods that are identical or ‘comparable’ to the goods covered by the PDO/PGI (see paragraph 2.10.2.3 below).

For these three conditions, reference is made below to: (i) which PDOs/PGIs may give rise to an objection under Article 7(1)(k) CTMR; (ii) under what circumstances a CTM contains or consists of a PDO/PGI in such a way that it falls under Article 13(1) of Regulation (EU) No 1151/2012; (iii) the goods of the CTM application affected by the protection granted to the PDO/PGI. Finally, reference is also made below to how goods can be restricted in order to waive an objection.

2.11.2 The application of Article 7(1)(k) CTMR

2.11.2.1 Relevant PDOs/PGIs

Article 7(1)(k) CTMR applies where PDOs/PGIs (either from an EU Member State or from a third country) have been registered under the procedure laid down by Regulation (EU) No 1151/2012.

For third-country PDOs/PGIs that enjoy protection in the European Union through international agreements concluded between the European Union and third countries, see paragraph 2.10.3.2 below.

Relevant information about PDOs/PGIs registered under Regulation (EU) No 1151/2012 can be found in the database ‘DOOR’ maintained by the Commission, which can be accessed through the internet at <http://ec.europa.eu/agriculture/quality/door/list.html>.

Protection is granted solely to the name of a PDO/PGI as registered (see Article 13(1) of Regulation (EU) No 1151/2012) and does not extend *ipso iure* to the names of sub-regions, sub-denominations, local administrative areas or localities in the area covered by that PDO/PGI. In this respect, a distinction must be made between the doctrine of the General Court in judgment of 11/05/2010, T-237/08, ‘Cuvée Palomar’ and the current legal framework. That judgment refers to a system of Member State competencies on the designation of geographical indications for wines that existed under previous Regulation (EC) No 1493/1999 but is no longer in force.

On the other hand, the trade agreements signed by the EU with third countries typically have annexed to them a list of the PDOs/PGIs registered at EU level that are also to be protected in the third countries in question (see judgment of 11/05/2010, T-237/08, ‘Cuvée Palomar’, paras 104-108 and decision of 19/06/2013, R 1546/2011-4 – ‘FONT DE LA FIGUERA’). However, examiners should not use those lists as a source of information about EU PDOs/PGIs but should refer to the database cited above. Firstly, the lists of EU PDOs/PGIs to be protected abroad may vary from one agreement to another, depending on the particularities of the negotiations. Secondly, the annexes to the agreements are usually amended and updated through an ‘Exchange of Letters’.

Article 7(1)(k) CTMR applies only in respect of PDOs/PGIs that were applied for before the CTM **and** are registered at the time of examining the CTM. The relevant dates for establishing the priority of a trade mark and of a PDO/PGI are the date of application of the CTM (or the so-called Paris Convention priority, if claimed) and the date of application for protection of a PDO/PGI to the Commission respectively.

Therefore, no objection will be raised under Article 7(1)(k) CTMR when the PDO/PGI was applied for **after** the filing date (or the priority date, if applicable) of the CTM application. Details of the date of application for the PDO/PGI are available in the 'DOOR' database.

Notwithstanding the above, and in view of the fact that the vast majority of applications for PDO/PGI usually mature in a registration, **an objection will be raised** when the PDO/PGI was applied for **before** the filing date (or the priority date, if applicable) of the CTM application **but** had not yet been registered at the time of examining the CTM application. However, if the CTM applicant submits that the PDO/PGI in question has not yet been registered, the proceedings will be suspended until the outcome of the registration procedure of the PDO/PGI

2.11.2.2 Situations covered by Article 13(1) of Regulation (EU) No 1151/2012

Article 7(1)(k) CTMR applies (provided that the other conditions also apply) in all of the following situations:

1. the CTM consists solely of a whole PDO/PGI ('direct use');
2. the CTM contains a whole PDO/PGI in addition to other word or figurative elements ('direct or indirect use');
3. the CTM contains or consists of an imitation or evocation of a PDO/PGI;
4. other misleading indications and practices;
5. the reputation of PDOs/PGIs

CTM consists solely of a whole PDO/PGI ('direct use')

This situation covers the 'direct use' of a PDO/PGI as a CTM, that is, the trade mark consists solely of the name of the PDO/PGI.

Examples

PDO/PGI	Community trade mark
DRESDNER CHRISTSTOLLEN (DE/PGI/005/0704)	DRESDNER CHRISTSTOLLEN (Collective CTM No 262 949)
PROSCIUTTO DI PARMA (IT/PDO/0117/0067)	PROSCIUTTO DI PARMA (Collective CTM No 1 116 458)

If the mark consists solely of the PDO/PGI, the CTM also falls under Article 7(1)(c) CTMR, since it is considered descriptive of the geographical origin of the goods in question. This means that the examiner's objection will simultaneously raise absolute grounds for refusal under both Article 7(1)(k) and 7(1)(c) CTMR. There is an exception to this, pursuant to Article 66(2) CTMR, when the CTM is a collective trade mark and the regulations governing use thereof include the particulars foreseen in Article 67(2) (for the contrary situation where the mark had been applied for as an individual mark, see decision of 07/03/2006, R 1073/2005-1, 'TEQUILA', para. 15).

While restricting the relevant goods (to comply with the specifications of the PDO/PGI) is usually a means of waiving the objection under Article 7(1)(k) CTMR (see paragraph 2.10.2.3 below), such restriction is irrelevant for Article 7(1)(c) CTMR.

For example, a CTM consisting of the expression 'PROSCIUTTO DI PARMA' for *meat* will simultaneously be objected to under both Article 7(1)(k) and Article 7(1)(c) CTMR: it consists solely of the PDO 'Prosciutto di Parma', which enjoys protection for *meat products*, namely a specific type of ham, and is therefore descriptive. If the goods are subsequently limited to *ham complying with the specifications of the PDO 'Prosciutto di Parma'*, the objection under Article 7(1)(k) CTMR will be waived but the trade mark is still descriptive and continues to be objectionable under Article 7(1)(c) CTMR, unless it has been applied for as a collective trade mark that complies with Article 67(2) CTMR.

CTM contains a whole PDO/PGI in addition to other word or figurative elements ('direct or indirect use')

This situation also covers the 'direct use' of a PDO/PGI in a CTM through reproduction of the name of the PDO/PGI together with other elements.

The following CTMs are considered to fall under Article 7(1)(k) CTMR since they contain the whole denomination of a PDO/PGI:

PDO/PGI	Community trade mark
<p>PROSCIUTTO DI PARMA (IT/PDO/0117/0067)</p>	<p>CONSORZIO DEL PROSCIUTTO DI PARMA (CTM No 6 380 141)</p>
<p>DRESDNER CHRISTSTOLLEN (DE/PGI/005/0704)</p>	 <p>(CTM No 5 966 668)</p>
<p>PARMIGIANO REGGIANO (IT/PDO/0117/0016)</p>	 <p>(CTM No 6 380 141)</p>

PDO/PGI	Community trade mark
<p style="text-align: center;">WELSH BEEF (UK/PGI/0005/0057)</p>	 <p style="text-align: center;">(CTM No 10 513 729)</p>

Under Article 7(1)(k) CTMR it is irrelevant whether or not the other word or figurative elements may give the trade mark distinctive character. The sign can be acceptable as a whole under Article 7(1)(b) and (c) CTMR and still be objectionable (as in the cases above) under Article 7(1)(k) CTMR.

There is 'indirect use' of a PDO/PGI, for example, when the PDO/PGI appears in a complex trade mark (such as the representation of a label) in smaller characters as information about the origin or type of the product or as part of the producer's address. In such cases the trade mark will be objectionable irrespective of the position or the size of the PDO/PGI within the trade mark as a whole, provided that it is visible.

PDO/PGI	Community trade mark
<p style="text-align: center;">WELSH LAMB (UK/PGI/0005/0081)</p>	 <p style="text-align: center;">(CTM No 11 927 472)</p>
<p style="text-align: center;">QUESO MANCHEGO (ES/PDO/0117/0087)</p>	 <p style="text-align: center;">(CTM No 5 582 267)</p>

CTM contains or consists of an imitation or evocation of a PDO/PGI

Neither the CTMR nor Regulation (EU) No 1151/2012 defines the meaning of ‘imitation’ or ‘evocation’. To a large extent, they are closely related concepts.

According to the Court, ‘evocation’ covers ‘a situation where the term used to designate a product incorporates part of a protected designation, so that when the consumer is confronted with the name of the product, the image triggered in his mind is that of the product whose designation is protected’ (judgment of 04/03/1999, C-87/97, ‘Cambozola’, para. 25 and judgment of 26/02/2008, C-132/05, para. 44).

The above means that there may be evocation when the CTM reproduces **part of** a PDO/PGI, such as (one of its) geographically significant word element(s) (in the sense that it is not a generic element), or even part of a word, such as a characteristic root or ending (examples are given below).

Moreover, Article 13(1)(b) of Regulation (EU) No 1151/2012 protects PDOs/PGIs against ‘any misuse, imitation or evocation, **even if the true origin of the products or services is indicated or if the protected name is translated or accompanied by an expression such as “ style”, “type”, “method”, “as produced in”, “imitation” or similar**’ (emphasis added), thus even if consumers are not misled.

According to the Advocate General (opinion of 17/12/1998, C-87/97, ‘Cambozola’, para. 33), ‘the term “evocation” is objective, so that it is not necessary to show that the owner of the mark intended to evoke the protected name’.

In this respect, and for the purposes of Article 7(1)(k) CTMR, the Office will assess in an equally objective way the situations described below, regardless of the CTM applicant’s actual intention.

Furthermore, the Office considers the terms ‘imitation’ and ‘evocation’ as two corollaries of essentially the same concept. The mark ‘imitates’ (mimics, reproduces elements of, etc.), with the result that the goods designated by the PDO/PGI are ‘evoked’ (called to mind).

In the light of the above, there is evocation or imitation of a PDO/PGI where:

- (a) the CTM incorporates the geographically significant part (in the sense that it is not the generic element) of the PDO/PGI;
- (b) the CTM contains an equivalent adjective/noun that indicates the same geographical origin;
- (c) the PDO/PGI is translated;
- (d) the CTM includes a ‘de-localizer’ expression in addition to the PDO/PGI or its evocation.

The CTM incorporates part of the PDO/PGI

According to the Court (judgment of 04/03/1999, C-87/97, ‘Cambozola’ and judgment of 26/02/2008, C-132/05, cited above), the CTM must trigger in the consumer’s mind the image of the product whose designation is protected.

The Court has also stated that ‘it is possible (...) for a protected designation to be evoked where there is no likelihood of confusion between the products concerned’ (judgment of 04/03/1999, C-87/97, ‘Cambozola’, para. 26).

Importantly, evocation is not assessed in the same way as likelihood of confusion (see opinion of the Advocate General of 17/12/1998, C-87/97, ‘Cambozola’, para. 37). A link must be made **with the product** whose designation is protected. Therefore, whether or not there is evocation will not be analysed according to the principles laid down by the CJEU in judgment of 11/11/1997, C-251/95, ‘Sabèl’.

As pointed out above, evocation is understood as encompassing not only when the CTM incorporates (one of) the geographically significant word(s) (as opposed to generic) element(s) of a PDO/PGI, but also when the CTM reproduces other parts of that PDO/PGI, such as a characteristic root or ending.

PDO/PGI	Trade Mark	Explanation
<p>CHIANTI CLASSICO (IT/PDO/0005/0108)</p>	 <p>(CTM No 9 567 851)</p>	<p>The term ‘chianti’ is an evocation of the PDO ‘Chianti Classico’ (R 1474/2011-2, ‘AZIENDA OLEARIA CHIANTI’, paras 14-15)</p>
<p>GORGONZOLA (IT/PDO/0017/0010)</p>	<p>CAMBOZOLA</p>	<p>‘... a protected name is indeed evoked where the term used to designate that product ends in the same two syllables and contains the same number of syllables, with the result that the phonetic and visual similarity between the two names is obvious’ (C-87/97, para. 27)</p>
<p>NÜRNBERGER BRATWÜRSTE/NÜRNBERGER ROSTBRATWÜRSTE (DE/PGI/0005/0184)</p>	<p>NUERNBERGA (CTM No 9 691 577)</p>	<p>‘due to the phonetic equivalence, NUERNBERGA is understood in the sense of the geographical indication Nürnberger’ (R 1331/2011-4, ‘NUERNBERGA’, para. 12)</p>

If a PDO/PGI contains or evokes the name of a product that is considered generic, protection does not extend to the generic element (see Article 13(1) of Regulation (EU) No 1151/2012, *in fine* and judgment of 12/09/2007, T-291/03, ‘Grana Biraghi’, paras 58 and 60). For example, in the PGIs ‘Maçã de Alcobaça’ and ‘Jambon d’Ardenne’, it is a well-known fact that the terms ‘maçã’ (apple in Portuguese) and ‘jambon’ (ham in French) are generic and therefore they do not deserve protection. Accordingly, no objection will be raised to the mere fact that a CTM contains those generic terms that are part of a PDO/PGI.

In particular, it must also be mentioned that the terms ‘camembert’ and ‘brie’ are generic (see judgment of 26/02/2008, C-132/05, para. 36). Other examples are ‘cheddar’ or ‘gouda’ (see Regulation (EC) No 1107/96, footnotes to the PDOs ‘West

Country farmhouse Cheddar’ and ‘Noord-Hollandse Gouda’). Therefore, no objection was raised in the following case:

PDO/PGI	Community trade mark
(none, because ‘camembert’ is not a geographical indication, but a generic term)	 <p>(CTM No 7 389 158)</p>

Where the generic nature of an element in a PDO/PGI can be determined by standard dictionary definitions, the perspective of the public in the country of origin of the PDO/PGI is determinative. For instance, in the examples cited above, it suffices that the terms ‘maçã’ and ‘jambon’ are generic for the Portuguese and French consumers, respectively, for it to be concluded that they are generic, regardless of whether or not these terms can be understood by other parts of the public in the European Union.

By contrast, where no definition can be found in a standard, well-known dictionary, the generic nature of the term in question should be assessed following the criteria laid down by the Court (see judgment of 26/02/2008, C-132/05 and judgment of 12/09/2007, T-291/03, ‘Grana Biraghi’), such as relevant national and EU legislation, how the term is perceived by the public, and circumstances relating to the marketing of the product in question.

Finally, in some cases a CTM may constitute direct/indirect use or evocation of more than one PDO/PGI at the same time. This is likely to happen when the CTM contains an element (not being a generic one) that appears in more than one PDO/PGI.

PDO/PGI	Community trade mark	Explanation
Amarene Brusche di Modena	 <p>(CTM No 11 338 779)</p>	The CTM contains the element ‘MODENA’ which evokes all PDOs/PGIs which include ‘MODENA’
Aceto Balsamico di Modena		
Aceto balsamico tradizionale di Modena		
Cotechino Modena		
Zampone Modena		
Prosciutto di Modena		

Provided that the CTM covers the relevant goods, an objection should be raised in respect of all the PDOs/PGIs concerned. However, the examiner will indicate that the objection cannot be overcome, because limiting the goods to those that comply with either one or all PDOs/PGIs would necessarily trigger another objection under Article 7(1)(k) CTMR since such a limitation would inevitably and confusingly identify goods with a geographical origin other than that of the PDO/PGI in question.

Equivalent adjectives/nouns

The use of an equivalent adjective/noun to indicate the same origin constitutes an evocation of a PDO/PGI:

PDO/PGI	Community trade mark (invented examples)	Explanation
JAGNIĘCINA PODHALAŃSKA (PL/PGI/0005/00837)	JAGNIĘCINA Z PODHALA	Adjective in the PGI → Noun in the CTM
MEL DO ALENTEJO (PT/PDO/0017/0252)	MEL ALENTEJANA	Noun in the PDO → Adjective in the CTM
SCOTTISH WILD SALMON (GB/PGI/0005/00863)	WILD SALMON FROM SCOTLAND	Adjective in the PGI → Noun in the CTM

Translated PDOs/PGIs

Likewise, there is evocation or imitation of the PDO/PGI when the CTM contains or consists of a translation of the whole or part of a PDO/PGI in any of the EU languages.

PDO/PGI	Community trade mark (invented example)	Explanation
PÂTES D'ALSACE (FR/PGI/0005/0324)	ALSATIAN PASTA	A CTM that contains the expression 'Alsatian Pasta' will be considered to evoke the PGI 'Pâtes d'Alsace'

Trade marks consisting of these terms must be refused under both Article 7(1)(k) and 7(1)(c) CTMR rather than solely under Article 7(1)(c) CTMR.

Expressions used as 'de-localisers'

According to Article 13(1)(b) of Regulation (EU) No 1151/2012, PDOs/PGIs are protected even 'if the true origin of the products or services is indicated or if the protected name is (...) accompanied by an expression such as "style", "type", "method", "as produced in", "imitation" ... or similar'.

Therefore, the fact that the PDO/PGI reproduced or evoked in the CTM is accompanied by these expressions does not militate against the application of Article 7(1)(k) CTMR. In other words, even if the public is thereby informed about the actual origin of the product, an objection will still be raised under Article 7(1)(k) CTMR. Notwithstanding this, the trade mark will be misleading under Article 7(1)(g) CTMR since there is a contradiction between the goods (restricted to the specific PDO/PGI) and the message conveyed by the mark (that the goods are not 'genuine' PDO/PGI products), which will thus necessarily lead to a further objection under that Article 7.

PDO/PGI	Community trade mark (invented examples)	Explanation
<p align="center">FETA</p> <p align="center">(EL/PDO/0017/0427)</p>	<p align="center">GREEK STYLE PLAIN FETA</p> <p align="center">ARABIAN FETA</p>	<p>A CTM that contains expressions such as 'Greek Style Plain Feta' or 'Arabian Feta', will be considered to evoke the PDO 'Feta', even if it conveys the idea that the product in question is not a 'genuine PDO Feta' cheese</p>

Where the applicant has its legal seat is irrelevant for assessing Article 7(1)(k) CTMR. Article 12(1) of Regulation (EU) No 1151/2012 sets out that protected designations of origin and protected geographical indications may be used by any operator marketing a product that conforms to the corresponding specification. Hence, provided that the goods comply with the specification of the PDO/PGI in question (which is guaranteed by restricting the goods appropriately), the location of the applicant's legal seat as indicated in the CTM application is irrelevant. For example, a company with legal domicile in Lithuania can own a factory located in Spain that elaborates products complying with the PGI 'Chorizo de Cantimpalos'.

Other misleading indications and practices

Article 13(1)(c) and (d) of Regulation (EU) No 1151/2012 protects the PDO/PGI against a number of false or misleading indications about the origin, nature or essential qualities of the product.

Although it very much depends on the particularities of each case, each of which must therefore be assessed individually, a CTM may be considered misleading when, for example, it contains figurative elements that are typically associated with the geographical area in question (such as well-known historical monuments) or when it reproduces a particular shape of the product.

The above must be interpreted in a restrictive way: it refers solely to CTMs that depict a well-known and singular image that is generally taken as a symbol of the particular place of origin of the products covered by the PDO/PGI or a singular shape of the product which is described in the specifications of the PDO/PGI.

PDO/PGI	Community trade mark (invented examples)	Explanation
<p align="center">MOULES DE BOUCHOT DE LA BAIE DU MONT-SAINT-MICHEL</p> <p align="center">(FR/PDO/0005/0547)</p>	<p>A CTM which contains an image of the Mont-Saint-Michel Abbey</p>	<p>A picture of the Mont-Saint-Michel Abbey is a well-known emblem of the city and island of Mont Saint Michel in Normandy. Use of this image for seafood other than that covered by the PDO 'Moules de Bouchot de la Baie du Mont-Saint-Michel' would fall under Article 13(1)(c) and (d) of Regulation (EU) No 1151/2012</p>
<p align="center">QUESO TETILLA</p> <p align="center">(ES/PDO/0017/0088)</p>	<p>A CTM which depicts a cheese conical in shape</p>	<p>The singular shape of the product is described in the specifications of the PDO 'Queso Tetilla'</p>

Given the inherent difficulty in identifying evocative figurative elements, particularly in less obvious cases, the Office will in such cases rely principally on objections by third parties.

The reputation of PDOs/PGIs

According to Article 13(1)(a) of Regulation (EU) No 1151/2012, registered names are protected against use that exploits the reputation of the protected name. This protection in principle extends even to different products (see judgment of 12/06/2007, joined cases T-53/04 to T-56/04, T-58/04 and T-59/04, ‘Budweiser’, para. 176).

However, the scope of such protection must be read in line with the mandate contained in Article 14 of the same regulation, which limits the refusal of trade marks to products ‘of the same type’.

Therefore, the Office considers that, in the context of examining absolute grounds for refusal, the PDO/PGI’s protection is limited to identical or comparable products.

However, the extended scope of protection of a PDO/PGI with reputation can be invoked in the context of Article 8(4) CTMR (see the Guidelines, Part C, Opposition, Part 4, Rights Under Article 8(4) CTMR).

2.11.2.3 Relevant goods

Comparable products

Objections based on Article 7(1)(k) CTMR can be raised only in respect of specific goods of the CTM application, namely those that are identical or ‘comparable’ to ones covered by the PDO/PGI.

The different terms used in Articles 13 and 14 of Regulation (EU) No 1151/2012 (‘comparable products’, and ‘products of the same type’ respectively) are interpreted by the Office as synonyms referring to the same concept.

The notion of **comparable goods** must be understood restrictively and it is independent of the analysis of similarity between goods in trade mark law. Accordingly, the criteria set out in judgment of 29/09/1998, C 39/97, ‘Canon’ should not necessarily be adhered to, although some of them may be useful. For example, given that a PDO/PGI serves to indicate the geographical origin and the particular qualities of a product, criteria such as the nature of the product or its composition are more relevant than, for instance, whether or not goods are complementary.

In particular, the CJEU (in judgment of 14/07/2011, joined cases C-4/10 and C-27/10, ‘BNI Cognac’, para. 54) has listed the following criteria for determining whether goods are comparable:

- whether or not they have common objective characteristics (such as method of elaboration, physical appearance of the product or use of the same raw materials);

- whether or not they are consumed, from the point of view of the relevant public, on largely identical occasions;
- whether or not they are distributed through the same channels and subject to similar marketing rules.

Although it is not possible in these Guidelines to list all the possible scenarios, the following are some examples of comparable products.

Products covered by the PDO/PGI	Comparable products
Specific meat and specific meat preparations	Any meat and any meat preparation (R 659/2012-5, p.14-17)
Milk	Cheese and other milk products
Fresh fruit	Preserved, frozen, dried and cooked fruits (jellies, jams, compotes are not 'comparable products', but the fruit covered by the PDO/PGI can be a commercially relevant ingredient, see below under 'Products used as ingredients')
Fresh vegetables	Preserved, frozen, dried and cooked vegetables (jellies, jams are not 'comparable products', but the vegetable covered by the PDO/PGI can be a commercially relevant ingredient, see below under 'Products used as ingredients')

Restrictions of the list of goods

According to Article 12(1) of Regulation (EU) No 1151/2012, 'protected designations of origin and protected geographical indications may be used by any operator marketing a product conforming to the corresponding specification'.

Objections raised under Article 7(1)(k) CTMR may be waived if the relevant goods are restricted to comply with the specifications of the PDO/PGI in question.

Restriction of goods can be a complex task, which may depend to a large extent on a case-by-case examination.

- **Products of the same type** as those covered by the PDO/PGI must be restricted in order to meet the specifications of the PDO/PGI. The proper wording is '[name of the product] complying with the specifications of the [PDO/PGI 'X']'. No other wording should be proposed or allowed. Restrictions such as '[name of the product] with the [PDO/PGI 'X']' or '[name of the product] originating in [name of a place]' are not acceptable.

PDO/PGI in the CTM	Acceptable list of goods
WELSH BEEF (UK/PGI/0005/0057)	Beef meat complying with the specifications of the PGI 'Welsh Beef'

The category of products that includes those covered by the PDO/PGI in question can be consulted in the 'DOOR' database. The exact product covered can be found in the

application document attached to the publication in the Official Journal, also accessible through 'DOOR'.

- The **category of products** that includes those covered by the PDO/PGI should be restricted to designate exactly the products covered by the PDO/PGI and that comply with its specifications.

PDO/PGI in the CTM	Original specification (which is not acceptable)	Acceptable list of goods	Explanation
WELSH BEEF (UK/PGI/0005/0057)	Meat	Beef meat complying with the specifications of the PGI 'Welsh Beef'	'Meat' includes products (e.g. pork) which cannot comply with the specifications of a particular PDO/PGI that covers the specific product 'beef meat'
POMME DU LIMOUSIN (FR/PDO/0005/0442)	Fruits	Apples complying with the specifications of the PDO 'Pomme du Limousin'	The category 'fruits' includes products such as pear or peaches which cannot meet the specifications of a PDO that exclusively covers apples

- **Comparable products** are restricted to those products, within the category of comparable products, covered by the PDO/PGI:

PDO/PGI in the CTM	Original specification (which is not acceptable)	Acceptable list of goods	Explanation
POMME DU LIMOUSIN (FR/PDO/0005/0442)	Preserved, frozen, dried and cooked fruits	Preserved, frozen, dried and cooked apples complying with the specifications of the PDO 'Pomme du Limousin'	'Preserved, frozen, dried and cooked fruits' includes products made of other fruits which cannot meet the specifications of a PDO which exclusively covers apples. Also to note that the limitation should not be for 'apples'.

There may be cases where the objection cannot be overcome by a limitation, for example, when the goods applied for, although 'comparable', do not include the product covered by the PDO/PGI (e.g. where the PDO covers 'cheese' and the goods applied for are 'milk').

- **Products used as ingredients:** if the goods covered by the PDO/PGI can be used as a commercially relevant ingredient (in the sense that it may determine the choice of the main product) of any of the goods included in the CTM application, a restriction will be requested. This is because Article 13(1)(a) and (b) of Regulation (EU) No 1151/2012 expressly extend the scope of protection of a PDO/PGI registered for a given product 'when those products are used as an ingredient'.

PDO/PGI in the CTM	Original specification (which is not acceptable)	Acceptable list of goods	Explanation
POMME DU LIMOUSIN (FR/PDO/0005/0442)	Jams and compotes	Jams and compotes of apples complying with the specifications of the PDO 'Pomme du Limousin'	The fruit is the main ingredient of jams and compotes
PROSCIUTTO DI PARMA (IT/PDO/0117/0067)	Pizzas	Pizzas with ham complying with the specifications of the PDO 'Prosciutto di Parma'	This topping is the main ingredient of a pizza and the one which determines the consumer's choice

A restriction is not necessary if the goods covered by the PDO/PGI are used as a secondary, not commercially relevant ingredient of the claimed goods.

PDO/PGI in the CTM	Original specification	Acceptable list of goods	Explanation
ACEITE DE LA ALCARRIA (ES/PDO/0005/0562)	Pastry	Pastry	The goods do not need to be restricted by the mere fact that oil is used in their preparation. 'Oil' is a secondary ingredient which is not commercially relevant

2.11.3 PDOs/PDIs not protected under Regulation (EU) No 1151/2012

2.11.3.1 PDOs/PDIs protected at national level in an EU Member State

The Court of Justice has set out (judgment of 08/09/2009, C-478/07, 'Bud') that the EU system of protection for PDOs/PGIs for agricultural products and foodstuffs laid down in Regulation (EC) No 510/2006 [then in effect] is 'exhaustive in nature'.

Article 9 of Regulation (EU) No 1151/2012 states that

a Member State may, on a transitional basis only, grant protection to a name under that Regulation at national level, with effect from the date on which an application is lodged with the Commission. Such national protection shall cease on the date on which either a decision on registration under that Regulation is taken or the application is withdrawn'. Those measures taken by Member States 'shall produce effects at national level only, and they shall have no effect on intra-Union or international trade.

This provision is in line with Recital 24 of the same regulation, which declares that

to qualify for protection in the territories of Member States, designations of origin and geographical indications should be registered only at Union level. With effect from the date of application for such registration at Union level, Member States should be able to grant transitional protection at national level without affecting intra-Union or international trade.

Moreover, reference must also be made to Council Regulation (EEC) No 2081/92 on the protection of geographical indications and designations of origin for agricultural products and foodstuffs. That regulation (which preceded and was repealed by Regulation (EC) No 510/2006) set out in Article 17(1) that Member States had 'to inform the Commission which of their legally protected names (...) they wish[ed] to register' pursuant to that regulation. Paragraph (3) added that Member States could 'maintain national protection of the names communicated in accordance with paragraph 1 until such time as a decision on registration has been taken' (see in this respect judgment of 04/03/1999, C-87/97, 'Cambozola', para. 18).

As a consequence of this, the former protection at national level of geographical indications for agricultural products and foodstuffs was discontinued once those geographical indications were registered at EU level.

Geographical indications for these kinds of products that in the past enjoyed protection by means of national legislation do not fall within the scope of Article 7(1)(k) CTMR. Accordingly, they do not constitute, as such and for that reason alone, a ground for refusal under Article 7(1)(k) CTMR, unless they have also been registered at EU level. Therefore, if for example a third party argues that a CTM contains or consists of a geographical indication for agricultural products and foodstuffs that was registered in the past at national level in an EU Member State, the examiner will check whether such geographical indication is also registered at EU level as a PDO/PGI. If not, the third party observations will be deemed not to raise serious doubts as regards Article 7(1)(k) CTMR.

2.11.3.2 PDOs/PDIs from third countries

The following situations refer to those PDOs/PGIs from third countries that are not simultaneously registered at EU level.

The geographical indication is protected only in the country of origin under national legislation

Article 7(1)(k) CTMR does not apply since the third-country geographical indication is not recognised and protected *expressis verbis* under EU legislation. In this respect, note that the provisions of the TRIPs Agreement are not such as to create rights upon which individuals may rely directly before the courts by virtue of EU law (judgment of 14/12/2000, joined cases C-300/98 and C-392/98, para. 44).

Nevertheless, when the CTM contains or consists of one such protected geographical indications, it must also be assessed whether or not the CTM may be considered descriptive and/or deceptive under Article 7(1)(c) and (g) CTMR in accordance with the general rules set out in these Guidelines. For example, where a third party observes that a CTM consists of the expression 'Tea Murakami' (invented example) which is a PGI in accordance with the national legislation of country X, Article 7(1)(k) CTMR will not apply for the reasons set out above, but it must be examined whether or not the CTM will be perceived as a descriptive and/or deceptive sign by the relevant EU consumers.

The geographical indication is protected under an agreement to which the European Union is a contracting party

The EU has signed a number of trade agreements with third countries that protect geographical indications. These instruments typically include a list of the geographical indications, as well as provisions on their conflicts with trade marks. The content and degree of precision may nevertheless vary from one agreement to another. Geographical indications from third countries are protected at EU level after the relevant agreement has entered into force.

In this respect, it is settled case-law that a provision of an agreement entered into by the EU with non-member countries must be regarded as being directly applicable when, in view of the wording, purpose and nature of the agreement, it may be concluded that the provision contains a clear, precise and unconditional obligation that is not subject, in its implementation or effects, to the adoption of any subsequent measure (judgment of 14/12/2000, joined cases C-300/98 and C-392/98, para. 42).

The scope of protection given to these PGIs by third countries is defined through the substantive provisions of the agreement concerned. While the oldest agreements (in particular in the field of wines and spirits) usually contained only general provisions, the 'last generation' of free trade agreements refer to the relationship between trade marks and PGIs in similar terms to those of Articles 13 and 14 of Regulation (EU) No 1151/2012 (see, for example, Articles 210 and 211 of the 'Trade Agreement between the European Union and its Member States, of the one part, and Colombia and Peru, of the other part', OJ L 354, 21/12/2012).

In the light of this, CTMs that contain or consist of a third-country PDO/PGI that is protected by an agreement to which the EU is a contracting party (and is not simultaneously registered under Regulation (EU) No 1151/2012) are examined, on a case-by-case basis, in accordance with the specific substantive provisions of the agreement in question on the refusal of conflicting trade marks, taking into account the case-law cited above. The mere fact that a PDO/PGI from a third country is protected by those instruments does not automatically imply that a CTM that contains or consists of the PDO/PGI must be refused: this will depend on the content and scope of the agreement's relevant provisions.

The geographical indication is protected under an international agreement signed only by Member States

Protection of geographical indications under agreements between two Member States is precluded under current EU regulation of the PDOs/PGIs for agricultural products and foodstuffs (judgment of 08/09/2009, C-478/07, 'Bud'). Such agreements are redundant and have no legal effect.

As regards international agreements signed exclusively by Member States with third countries (in particular, the Lisbon Agreement for the Protection of Appellations of Provenance and their International Registration), and for the sole purpose of the examination of absolute grounds for refusal, the EU is not a contracting party to these agreements, and they do not impose any obligations on the EU (see, by analogy, judgment of 14/10/1980, 812/79, para. 9).

2.12 Community collective marks

2.12.1 Character of collective marks

A Community collective mark (CCTM) is a specific type of CTM which, pursuant to Article 66(1) CTMR, 'is described as such when the mark is applied for and is capable of distinguishing the goods or services of the members of the association which is the proprietor of the mark from those of other undertakings'.

A Community collective mark is aimed at distinguishing the goods and services of the members of the association which owns the mark from those of other companies which do not belong to that association. Therefore, the Community collective mark qualifies the commercial origin of certain goods and services by informing the consumer that the producer of the goods or the service provider belongs to a certain association and that it has the right to use the mark.

A CCTM is typically used by companies, together with their own individual marks, to indicate that they are members of a certain association. For example, Spain's Association of Shoe Manufacturers may want to apply for the collective trade mark 'Asociación Española de Fabricantes de Calzado', which, while belonging to the association, is going to be used by all its members. A member of the association may want to use the collective mark in addition to its own individual mark, for example, 'Calzados Luis'.

Collective marks do not necessarily certify the quality of the goods, although this is sometimes the case. For example, regulations governing use frequently contain provisions to certify the quality of the goods and services of the members of the association and this is acceptable (see decision of 10/05/2012, R 1007/2011-2, para. 13).

It is up to the applicant to decide whether the trade mark fulfils the requirements of a collective mark or of an individual mark. This means that, in principle, the same sign could be applied for either as an individual CTM or, if the conditions described in this chapter are met, as a collective CTM. Differences between individual and collective marks do not depend on the signs per se, rather they depend on other characteristics such as the ownership or the conditions of use of the mark.

For example, an association can file an application for the word mark 'Tamaki' either as an individual mark or as a collective mark, depending on the use which is intended to be made of the mark (only by the association itself or also by the members thereof). If it is applied for as a CCTM, certain additional formalities must be met, such as the submission of regulations of use, etc.

After filing, changes of the kind of mark (from collective to individual or vice versa) are accepted only under certain circumstances (see the Guidelines, Part B, Examination, Section 2, Examination of Formalities, paragraph 8.2.5).

The CTMR provisions apply to CCTMs, unless Articles 67-74 CTMR provide otherwise. CCTMs are thus subject, on the one hand, to the general CTM regime and, on the other hand, to some exceptions and particularities.

It follows, firstly, that a CCTM is subject to broadly the same examination procedure and conditions as individual marks. In general terms, the classification of goods and services, examination of formalities and of absolute grounds for refusal is done according to the same procedure as that applied to individual trade marks.

For example, examiners will check the list of goods and services or the language requirements in the same way as they do with individual trade marks. Likewise, whether the CCTM falls under one of the grounds for refusal of Article 7 CTMR will also be examined.

The regulations provided by the applicant governing the use of its CCTM **must cover its use for all the goods and services** included in the list of the CCTM application. For instance, the applicant may do so by reproducing the list of goods and services in the regulations of use or by referring to the list of goods and services of the CCTM application.

With respect to CCTMs conflicting with PGIs/PDOs, the regulations governing the use of a CCTM should accurately reflect **any limitation** introduced to overcome such conflict. For example, the regulations of use of the CCTM 'XYZ Designation of Origin' for 'wines' should accurately reflect the fact that they refer to the use of the trade mark for *wines complying with the PDO 'XYZ'*.

Secondly, the examination of a CCTM will also consider the exceptions and particularities of this kind of mark. These exceptions and particularities refer both to the formal and substantive provisions. As regards formalities, the requirement of the regulations governing use of the mark is, for example, a specific characteristic of a CCTM. (For further details of the examination of formalities of CCTMs, including the regulations of use of the mark, see the Guidelines, Part B, Examination, Section 2, Examination of Formalities, paragraph 8.2 Collective marks).

The substantive exceptions and particularities which apply to a CCTM are described below.

2.12.2 Ownership

Ownership of CCTMs is limited to (i) associations of manufacturers, producers, suppliers of services, or traders which, under the terms of the law governing them, have the capacity in their own name to have rights and obligations of all kinds, to make contracts or accomplish other legal acts and to sue and be sued; and (ii) legal persons governed by public law.

The first type of owners typically comprises private associations with a common purpose or interest. They must have their own legal personality and capacity to act. Therefore, private companies such as *sociedades anónimas*, *Gesellschaften mit beschränkter Haftung*, etc., multiple applicants with separate legal personality or temporary unions of companies cannot be owners of a CCTM. As set out in the Guidelines, Part B, Examination, Section 2, Examination of Formalities, paragraph 8.2.1, 'collective does not mean that the mark belongs to several persons (co-applicants/co-owners) nor that it designates/covers more than one country'.

As regards the second type of owners, the concept 'legal persons governed by public law' must be interpreted broadly. This concept includes, on the one hand, associations,

corporations and other entities governed by public law. This is, for example, the case of 'Consejos Reguladores' or 'Colegios Profesionales' under Spanish Law. On the other hand, it also includes other legal persons governed by public law, for example, the European Union, States or municipalities, which do not necessarily have a corporative or an associative structure but which can nevertheless be owners of CCTMs. In these cases, the requirement concerning the conditions for membership under Article 67(2) CTMR is not applicable (see decision of 22/11/2011, R 828/2011-1, para. 18 and decision of 10/05/2012, R 1007/2011-2, paras 17, 18). That is to say, when the applicant for a CCTM is a legal person governed by public law which does not necessarily have a corporative or an associative structure, such as the European Union, a State or a municipality, the regulations governing use of the mark need not contain details concerning membership.

2.12.3 Particularities as regards absolute grounds for refusal

The absolute grounds for refusal listed in Article 7(1) CTMR apply to CCTMs. This means that these marks will first be examined under those provisions to verify, for example, whether or not they are distinctive, deceptive or have become a customary sign. If, for instance, a mark is not inherently distinctive under Article 7(1)(b) CTMR, it will be refused (see decision of 18/07/2008, R 229/2006-4, para. 7).

However, there are some exceptions and particularities which must also be taken into account when examining the absolute grounds for refusal for CCTMs. In addition to the grounds for refusal of a CTM application contained in Article 7(1) CTMR, examiners also assess the following specific grounds:

- descriptive signs
- misleading character as to its nature
- regulations of use contrary to public policy and morality.

These specific grounds for refusals can also be the object of observations filed by third parties.

2.12.3.1 Descriptive signs

Signs or indications which may serve, in trade, to designate the geographical origin of the goods or services may constitute Community collective marks (see judgment of 15/10/2003, T-295/01, para. 32 and judgment of 25/10/2005, T-379/03, para. 35).

As a result, a sign which exclusively describes the geographical origin of the goods or services (and which must be refused if it is applied for as an individual CTM) can be accepted if (i) it is validly applied for as a CCTM and (ii) it complies with the authorisation foreseen in Article 67(2) CTMR (see decision of 05/10/2006, R 280/2006-1, paras 16, 17).

According to this provision, the regulations governing use of a CCTM which is descriptive must authorise any person whose goods or services originate in the geographical area concerned to become a member of the association which is the proprietor of the mark.

For example, an application for the word mark 'Alicante', specifying *tourist services* should be refused under Article 7(1)(c) CTMR if it is applied for as an individual CTM given that it describes the geographical origin of the services. However, as an exception, if it is validly applied for as a CCTM (i.e. it is applied for by an association or a legal person governed by public law and it complies with the other requirements of Community collective marks) and the regulations governing use of the mark contain the authorisation foreseen in Article 67(2) CTMR, it will be accepted under Article 7(1)(c) CTMR.

This exception exclusively applies to those signs which are descriptive of the geographical origin of the goods and services. If the CCTM is descriptive of other characteristics of the goods or services, this exception does not apply and the application will be refused under Article 7(1)(c) CTMR.

For example, if the word mark 'Do-it-yourself' is applied for as a CCTM for tools in Class 7, it will be considered descriptive of the intended purpose of the goods. Since the sign is descriptive of certain characteristics of the goods other than their geographical origin, it will be refused under Article 7(1)(c) CTMR despite having been applied for as a CCTM (see decision of 08/07/2010, R 934/2010-1, para. 35).

2.12.3.2 Misleading character as to its nature

The examiner must refuse the application if the public is liable to be misled as regards the character or the meaning of the mark, in particular if it is likely to be perceived as something other than a collective mark.

A collective mark which is available for use only by members of an association which owns the mark could be liable to mislead if it gives the impression that it is available for use by anyone who is able to meet certain objective standards.

2.12.3.3 Regulations of use contrary to public policy and morality

If the regulations governing use of the mark are contrary to public policy or to accepted principles of morality, the CCTM application must be refused.

This ground for refusal must be differentiated from that contained in Article 7(1)(f) CTMR, which prohibits registration of those trade marks which are by themselves contrary to public policy or to accepted principles of morality.

The refusal foreseen in Article 68(1) CTMR refers to situations where, regardless of the trade mark, the regulations governing use of the mark contain a provision which is contrary to public policy or to accepted principles of morality, for instance rules which discriminate on the grounds of sex, creed or race. For example, if the regulations contain a clause which prohibits women from using the mark, the CCTM application will be refused, even if the trade mark does not fall under Article 7(1)(f) CTMR.

The examiner's objection can be waived if the regulations are amended in order to remove the conflicting provision. In the above example, the CCTM application will be accepted if the clause which prohibits women from using the mark is deleted from the regulations.

***GUIDELINES FOR EXAMINATION IN THE
OFFICE FOR HARMONIZATION IN THE
INTERNAL MARKET (TRADE MARKS AND
DESIGNS) ON COMMUNITY TRADE MARKS***

PART C

OPPOSITION

SECTION 3

***UNAUTHORISED FILING
BY AGENTS OF THE TM PROPRIETOR
(ARTICLE 8(3) CTMR)***

Table of Contents

1	Preliminary Remarks	3
1.1	Origin of Article 8(3) CTMR	3
1.2	Purpose of Article 8(3) CTMR	3
2	Entitlement of the Opponent	4
3	Scope of Application	5
3.1	Kinds of mark covered	5
3.2	Origin of the earlier mark	6
4	Conditions of Application	7
4.1	Agent or representative relationship	7
4.1.1	Nature of the relationship	7
4.1.2	Form of the agreement	9
4.1.3	Territorial scope of the agreement	10
4.1.4	Relevant points in time	11
4.2	Application in the agent's name	12
4.3	Application without the proprietor's consent	14
4.4	Absence of justification on the part of the applicant	16
4.5	Applicability beyond identical signs – goods and services	18

1 Preliminary Remarks

According to Article 8(3) CTMR, upon opposition by the proprietor of an earlier trade mark, a trade mark shall not be registered:

where an agent or representative of the proprietor of the trade mark applies for registration thereof in his own name without the proprietor's consent, unless the agent or representative justifies his action.

1.1 Origin of Article 8(3) CTMR

Article 8(3) CTMR has its origin in Article 6^{septies} of the Paris Convention which was introduced into the Convention by the Revision Conference of Lisbon in 1958. The protection it affords to trade mark proprietors consists of the right to prevent, cancel, or claim as their own unauthorised registrations of their marks by their agents or representatives, and to prohibit use thereof, where the agent or representative cannot justify its acts. Article 6^{septies} reads as follows:

(1) If the agent or representative of the person who is the proprietor of the mark in one of the countries of the Union applies, without such proprietor's authorisation, for the registration of the mark in his own name, in one or more countries of the Union, the proprietor shall be entitled to oppose the registration applied for, or demand its cancellation or, if the law of the country so allows, the assignment in his favour of the said registration, unless such agent or representative justifies his action.

(2) The proprietor of the mark shall, subject to the provisions of paragraph (1), above, be entitled to oppose the use of his mark by his agent or representative if he has not authorised such use.

(3) Domestic legislation may provide an equitable time limit within which the proprietor of a mark must exercise the rights provided for in this Article.

Article 8(3) CTMR implements this provision only to the extent it gives the rightful proprietor the right to oppose applications filed without its authorisation. The other elements of Article 6^{septies} of the Paris Convention are implemented by Articles 11, 18 and 53(1)(b) CTMR. Article 53(1)(b) CTMR gives the proprietor the right to cancel unauthorised registrations, whereas Articles 11 and 18 CTMR enable the proprietor to prohibit the use thereof and/or to request the transfer of the registration to its own name.

Since Article 41 CTMR provides that an opposition may only be based on the grounds provided for in Article 8, the additional rights conferred on the proprietor by the above provisions may not be invoked in opposition proceedings. Hence, any request by the opponent, either for the prohibition of use of the agent's mark, or for an assignment of the application to itself, will be dismissed as inadmissible.

1.2 Purpose of Article 8(3) CTMR

The unauthorised filing of the proprietor's trade mark by its agent or representative is contrary to the general obligation of trust underlying commercial co-operation

agreements of this type. Such a misappropriation of the proprietor's mark is particularly harmful to its commercial interests, as the applicant may exploit the knowledge and experience acquired during its business relationship with the proprietor and, thus, improperly benefit from the proprietor's effort and investment (confirmed by judgment of 06/09/2006, T-6/05, 'First Defense (I)', para. 38 and subsequent references in, inter alia, Board of Appeal decisions of 16/05/2011, R 0085/2010-4, 'Lingham's', para. 14, of 03/08/2010, R 1231/2009-2, 'Berik', para. 24, and of 30/09/2009, R 1547/2006-4, 'Powerball', para. 17).

Therefore, the purpose of Article 8(3) CTMR is to safeguard the legitimate interests of trade mark proprietors against the arbitrary appropriation of their trade marks, by granting them the right to prohibit registrations by agents or representatives that are applied for without their consent.

Article 8(3) CTMR is a manifestation of the principle that commercial transactions must be conducted in good faith. Article 52(1)(b) CTMR, which allows for the declaration of invalidity of a CTM on the ground that the applicant was acting in bad faith, is the general expression of this principle.

However, the protection granted by Article 8(3) CTMR is narrower than the one afforded by Article 52(1)(b) CTMR, because the applicability of Article 8(3) CTMR is subject to the fulfilment of a number of additional conditions laid down in this provision.

Consequently, the fact that the applicant filed the application in bad faith will not be in itself sufficient for the purposes of Article 8(3). Therefore, the opposition will be rejected if, despite being based exclusively on the bad faith of the applicant, it does not fulfil the necessary cumulative conditions required by Article 8(3) CTMR (set out in paragraph 4 below). Such a filing may only be sanctioned under Article 52(1)(b) by requesting the cancellation of the mark after it has been registered.

2 Entitlement of the Opponent

According to Article 41(1)(b) CTMR, the right to file an opposition on the grounds of Article 8(3) CTMR is reserved only for the proprietors of the earlier trade marks. This is in contrast both to Article 41(1)(a) CTMR, which stipulates that oppositions based on Article 8(1) CTMR or 8(5) CTMR may also be filed by authorised licensees, and to Article 41(1)(c) CTMR, which stipulates that for oppositions based on Article 8(4) CTMR the right to file an opposition is also extended to persons authorised by national law to exercise the relevant rights.

It follows that since the right to oppose a CTM application on the grounds of Article 8(3) CTMR belongs exclusively to the proprietors of the earlier trade marks, oppositions filed in the name of third persons, be they licensees or otherwise authorised by the relevant national laws, will be dismissed as inadmissible due to lack of entitlement.

Case No	Comment
Decision of 30/09/2009, R 1547/2006-4 'Powerball' (confirmed by judgment of 16/11/2011, T-484/09, 'Powerball')	The Board confirmed OD's decision rejecting the opposition based on Article 8(3) CTMR to the extent that the opponent was not the proprietor of the earlier right but merely claimed to be the licensee of the company Nanosecond Technology Co. Ltd.

Case No	Comment
Decision of 14/06/2010, R 1795/2008-4 'ZAPPER-CLICK' (on appeal, judgment of 03/10/2012, T-360/10, 'ZAPPER-CLICK')	The respondent failed to meet the requirement regarding ownership of the trade mark, namely of the ownership of the registered mark ZAPPER-CLICK. On appeal, the Court did not address this point.

Likewise, if the opponent fails to prove that it was the rightful proprietor of the mark when the opposition was filed, the opposition will be dismissed without any examination of its merits due to lack of substantiation. The evidence required in each case will depend on the kind of right relied upon. The current proprietor may also invoke the rights of its predecessor in title if the agency/representation agreement was concluded between the previous proprietor and the applicant, but this needs to be duly substantiated by evidence.

3 Scope of Application

3.1 Kinds of mark covered

Article 8(3) CTMR applies to earlier 'trade marks' that have been applied for as Community trade marks without their proprietor's consent. However, Article 8(2) CTMR does not apply to oppositions based on this ground, as it only enumerates the kinds of earlier rights on which an opposition may be entered under paragraphs (1) and (5) of the same article. Therefore, the kinds of rights on which an opposition based on Article 8(3) CTMR may be entered needs to be determined in more detail, both as regards their nature and their geographical origin.

In the absence of any restriction in Article 8(3) CTMR and in view of the need to provide effective protection to the legitimate interests of the real proprietor, the term 'trade marks' should be interpreted broadly and must be understood as including **pending applications**, since there is nothing in this provision restricting its scope exclusively to registered trade marks.

For the same reasons **unregistered marks or well-known marks** within the meaning of Article 6^{bis} of the Paris Convention also fall within the term 'trade marks' within the sense of Article 8(3) CTMR. Consequently, both registered and unregistered trade marks are covered by this provision, to the extent of course that the law of the country of origin recognises rights of the latter kind.

In contrast, the express reference to 'trade marks' means that Article 8(3) CTMR **does not apply to mere signs used in the course of trade**, *other* than unregistered trade marks. Likewise, **other kinds of intellectual property rights** that could be used as a basis for an invalidity action cannot be invoked in the context of Article 8(3) CTMR either.

Case No	Comment
Decision of 08/06/2010, B 1 461 948 'Gu Tong Tie Gao'	As Article 8(3) refers only to earlier trade marks, the evidence filed by the opponent with regard to rights in respect of copyright law in the territory of China was not relevant. This is another kind of intellectual property right which is excluded as a result of the express reference in the article to 'trade marks'.

It is clear from the wording of Article 8(3) CTMR that the trade mark on which the opposition is based must be **earlier** than the CTM application. Hence, the **relevant point in time** that should be taken into account is the **filing or priority date** of the contested application. The rules according to which the priority should be determined depends on the kind of right relied upon. If the earlier right has been acquired by registration, it is its priority date that should be taken into account for assessing whether it precedes the application, whereas if it is a user-based right, it must have been acquired before the filing date of the CTM application. In the case of earlier well-known marks, the mark must have become well-known by the time the CTMA is applied for.

Case No	Comment
Decision of 21/12/2009, R 1621/2006-4, 'D-Raintank'	The Board noted that the trade mark applications filed by the cancellation applicant in 2003 were all later than the filing date of the contested CTM and even later than its date of registration, and could not serve to establish that the cancellation applicant owned a 'mark' in the sense of a registered mark, be it anywhere in the world, for the sign at issue when the CTM was filed. It went on to affirm that 'Obviously, nobody can base a claim on relative grounds for refusal or declaration of invalidity on rights which are younger than the contested CTM' (para. 53).
Decision of 19/06/1999, B 3 436, 'NORAXON'	The period to be taken into account in order to determine the applicability of Article 8(3) CTMR starts on the date on which the CTM application in question came into force, i.e. 26/10/1995. This was the <u>priority date</u> in Germany, claimed by the applicant, granted by the Office and subsequently published, and not the filing date of the CTM application at the Office.

3.2 Origin of the earlier mark

As Article 8(2) CTMR does not apply to oppositions based on Article 8(3) CTMR, it cannot serve to define the territorial extent of protection granted by Article 8(3) CTMR. In the absence of any other reference in Article 8(3) CTMR to a 'relevant territory', it is **immaterial whether the earlier trade mark rights reside in the European Union or not**.

The practical importance of this provision lies precisely in the legal capacity it confers on holders of trade mark rights **outside the European Union** to defend these rights against fraudulent filings, since proprietors of trade mark rights within the European Union may rely on the other grounds provided for in Article 8 CTMR to defend their earlier rights from such acts. Of course, Community trade marks or national marks, which provide a basis for opposition pursuant to Article 8 CTMR, also qualify as earlier marks that can be invoked as a basis for an Article 8(3) CTMR opposition.

Case No	Comment
Decision of 19/12/2006, B 715 146, 'SQUIRT'	For the purpose of Article 8(3), it is immaterial where in the world the rights of proprietorship reside. Indeed, if in the Paris Convention <u>the proprietorship in a Paris Union member country</u> is required, in the absence of any reference in the CTMR to any territory in which such proprietorship shall exist, one must conclude that it is sufficient that the opponent complies with the requirements of Article 5 CTMR concerning 'Persons who can be proprietors of Community trade marks'. In the present case, the opponent complied with such a requirement, as it was a company based in the USA.

Case No	Comment
Decision of 10/01/2011, 3253 C, 'MUSASHI' (fig. mark) Cancellation proceedings	The fact that the earlier registrations were from non-EU countries has no bearing on the invalidity ground at issue, since Article 8(2) CTMR, imposing this territorial condition, does not apply to proceedings based on Article 8(3) CTMR and cannot serve to define the territorial extent of protection granted by that article. 'In the absence of any reference to a "relevant territory" in Article 8(3) CTMR, the Cancellation Division must presume that earlier trade marks registered in countries outside the EU may constitute the basis for an invalidity request based on Article 8(3) CTMR' (para. 33).
Decision of 26/01/2012, R 1956/2010-1 'Heatstrip' (confirmed by T-184/12)	The opposition was based on an unregistered mark protected, inter alia, in Australia. The Board considered that the evidence submitted by the opponent supports that it has been using the mark in Australia to a substantial extent (paras 3 and 34 respectively).
Decision of 19/05/2011, R 0085/2010-4 'Lingham's' (fig. mark)	The opposition was based on a registered mark protected in Malaysia. By filing the Malaysian registration certificate, it was proven that the opponent is the owner of the Malaysian trade mark.

4 Conditions of Application

Article 8(3) CTMR entitles trade mark proprietors to oppose the registration of their marks as Community trade marks, provided the following substantive cumulative requirements are met (see judgment of 13/04/2011, T-262/09, 'First Defense' (II), para. 61):

1. The applicant is or was an agent or representative of the proprietor of the mark;
2. The application is in the name of the agent or representative;
3. The application was filed without the proprietor's consent;
4. The agent or representative fails to justify its acts;
5. The signs are identical or with slight modifications and the goods and services are identical or closely related.

4.1 Agent or representative relationship

4.1.1 Nature of the relationship

In view of the purpose of this provision, which is to safeguard the legal interests of trade mark proprietors against the misappropriation of their trade marks by their commercial associates, the terms 'agent' and 'representative' should be **interpreted broadly** to cover all kinds of relationships based on any business arrangement (governed by written or oral contract) where one party is representing the interests of another, regardless of the *nomen juris* of the contractual relationship between the principal-proprietor and the CTM applicant (confirmed by judgment of 13/04/2011, T-262/09 'First Defense' (II), para. 64).

Therefore, it is sufficient for the purposes of Article 8(3) CTMR that there is some agreement of commercial co-operation between the parties of a kind that gives rise to a **fiduciary relationship** by imposing on the applicant, whether expressly or implicitly, a general duty of **trust and loyalty** as regards the interests of the trade mark proprietor. It follows that Article 8(3) CTMR may also extend, for example, to licensees of the proprietor, or to authorised distributors of the goods for which the mark in question is used. The **burden of proof** regarding the existence of an agent-principal relationship

lies with the opponent (confirmed by the judgment of 13/04/2011, T-262/09 'First Defense' (II), paras 64 and 67).

Case No	Comment
Judgment of 09/07/ 2014, T-184/12 'Heatstrip'	The Board of Appeal concluded that, although there was no written co-operation agreement between the parties, their relationship on the date of the application for the CTM was, in view of the business correspondence between them, more than that of merely buyer and seller. There was, rather, a tacit cooperation agreement that led to a fiduciary obligation on the part of the CTM applicant (para. 67).
Decision of 29/02/2012, B 1 818 791, 'HOVERCAM' (fig. mark)	The Opposition Division found that the evidence submitted by the opponent showed that the relationship and its ultimate purpose constituted an example of commercial cooperation, through which a general duty of trust and loyalty was imposed on the applicant and was the type of relationship envisioned under Article 8(3) CTMR (p. 5).

Given the variety of forms that commercial relationships may acquire in practice, a **case-by-case approach** is applied, focusing on whether the contractual link between the proprietor-opponent and the applicant is only limited to a series of occasional transactions, or if, conversely, it is of such a duration and content to justify the application of Article 8(3) CTMR (as regards the points in time which are crucial for the relationship, see below, paragraph 4.1.4). The material question should be whether it was the co-operation with the proprietor that gave the applicant the possibility to get to know and appreciate the value of the mark and incited the applicant to subsequently try to register the mark in its own name.

Nevertheless, some kind of co-operation agreement has to exist between the parties. If the applicant acts completely **independently**, without having entered into any kind of fiduciary relationship with the proprietor, it cannot be considered an agent within the meaning of Article 8(3) CTMR (confirmed by judgment of 13/04/2011, T-262/09 'First Defense' (II), para. 64).

Case No	Comment
Decision of 16/06/2011, 4103 C, 'D'Angelico' (fig. mark) Cancellation proceedings.	The Cancellation Division found that rather than an agent or representative relationship, at the time of filing the CTM the parties held parallel and independent rights to the marks in the USA and Japan. For these reasons, Article 8(3) CTMR was not applicable .

Case No	Comment
Decision of 17/03/2000, B 26 759 'EAST SIDE MARIO'S'	A mere desire to establish a commercial relationship with the opponent cannot be considered as a concluded agreement between the parties regarding the use of the contested trade mark.

Therefore, a **mere customer or a client** of the proprietor cannot amount to an 'agent or representative' for the purposes of Article 8(3) CTMR, since such persons are under no special obligation of trust to the trade mark proprietor.

Case No	Comment
Judgment of 13/04/2011, T-262/09, 'First Defense' (II)	The opponent did not submit any evidence showing the existence of an agent-principal relationship with the applicant. The opponent provided invoices and order forms addressed to itself, on the basis of which the existence of a business agreement between the parties could, in other circumstances, be assumed. However, in the present case, the GC concluded that the evidence does not show that the applicant acted on behalf of the opponent, but merely that there was a seller-customer relationship which could have been established without a prior agreement between them. Such a relationship is not sufficient for Article 8(3) CTMR to be applicable (para. 67).
Decision of 26/06/2009, B 955 528 'FUSION' (fig. mark)	The Office considered that the evidence on the kind of commercial link between the opponent and the applicant was inconclusive, that is, it could not be established whether the applicant was really an agent or representative or a mere purchaser of the opponent's goods. Accordingly, the Office was unable to hold that Article 8(3) CTMR applied.

It is irrelevant for the purposes of Article 8(3) CTMR whether an **exclusive** agreement exists between the parties, or just a simple, non-exclusive commercial relationship. Indeed, a commercial co-operation agreement entailing an obligation of loyalty can exist even in the absence of an exclusivity clause (see judgment of 09/07/2014, T-184/12 'Heatstrip', para. 69).

Article 8(3) CTMR also applies to **analogous** forms of business relationships that give rise to an obligation of trust and confidentiality between the trade mark proprietor and the professional, as is the case with legal practitioners and attorneys, consultants, trade mark agents etc. However, the legal representative or manager of the opponent's company cannot be considered as an agent or representative within the meaning of Article 8(3) CTMR, given that such persons are not business associates of the opponent. The purpose of this provision is not to protect the proprietor from infringing acts coming from within its company. It may well be that such acts can be sanctioned under the general bad faith provision in Article 52(1)(b) CTMR.

Case No	Comment
Decision of 20/03/2000, B 126 633 'Harpoon' (fig. mark)	In this case, the applicant was a legal representative of the opponent's company. The opposition was rejected.

4.1.2 Form of the agreement

It is not necessary that the agreement between the parties assumes the form of a written contract. Of course, the existence of a formal agreement between the parties will be of great value in determining exactly what kind of relationship exists between them. As mentioned above, the title of such an agreement and the terminology chosen by the parties should not be taken as conclusive. What counts is the kind of commercial co-operation established in substance and not its formal description.

Even in cases where a written contract does not exist, it may still be possible to infer the existence of a commercial agreement of the kind required by Article 8(3) CTMR by reference to indirect indications and evidence, such as the commercial correspondence between the parties, invoices and purchase orders for goods sold to the agent, or credit notes and other banking instruments (always bearing in mind that a mere customer

relationship is insufficient for Article 8(3) CTMR). Even dispute resolution agreements may be relevant to the extent they give sufficient information about the past relationship between the parties.

Case No	Comment
Decision of 07/07/2003, R 336/2001-2 'GORDON and SMITH' (fig. mark)	The Opposition Division was correct to conclude that there was an agency relationship between the applicant and the opponents, on the basis of correspondence indicating that the two parties had a long and close commercial relationship. The applicant company acted as a distributor of the opponents' goods (para. 19).

Furthermore, circumstances such as sales targets imposed on the applicant, or payment of royalties, or production of the goods covered by the mark under license or help in the setting up of a local distribution network, will be strong indications in the direction of a commercial relationship of the type covered by Article 8(3) CTMR.

The Court also decided that active co-operation between a C TM applicant and an opponent in the advertising of the product, in order to optimise the marketing thereof, could give rise to the fiduciary relationship required under Article 8(3) CTMR.

Case No	Comment
Decision of 26/01/2012, R 1956/2010-1 'Heatstrip' (appealed confirmed by T-184/12)	The Court confirmed the findings of the Board, who considered that a binding contractual relationship could be established by means of <u>business letters exchanged</u> by the parties, including by email. The Board examined the e-mail correspondence between the parties to determine what each party asked from the other (para. 50). The Board concluded that the emails showed that both parties were actively cooperating in the promotion of the product, by advertising it in brochures and exhibiting it at a fair, in order to create the best conditions for its successful marketing: the opponent supplied the material for these purposes and the applicant adapted it to the German market (para. 54). The Board thus concluded that the e-mail correspondence denoted an agreement of commercial co-operation between the parties of a kind that gives rise to a fiduciary relationship (para. 56). The Court dismissed the applicant's arguments that there was no co-operation between the parties (because the applicant was not integrated in the opponent's sales structure, was not subject to a no-competition clause and had to bear the costs of sale and promotion) and confirmed the Board's decision (para. 67 et seq).

On the other hand, the mere desire of the applicant to enter into a commercial relationship with the opponent cannot be considered as a concluded agreement between the parties. Prospective agents or representatives are not covered by Article 8(3) CTMR (see B 26 759 'East Side Mario's', quoted above).

4.1.3 Territorial scope of the agreement

Even though the letter of Article 8(3) CTMR does not refer to the territorial scope of the agreement between the trade mark proprietor and its agent or representative, **an inherent limitation to relationships covering the EU or a part thereof must be read in this provision.**

This is more in line with the economic considerations underlying Article 8(3), which are to prevent agents or representatives from unduly exploiting a commercial relationship covering a given territory, by filing an unauthorised application for the principal's mark precisely in that territory, that is, in the territory where the applicant will be more able to benefit from the infrastructure and know-how it possesses as a result of its prior relationship with the proprietor. Therefore, as the filing prohibited by Article 8(3) CTMR is an application for the acquisition of trade mark rights in the EU, the agreement must also concern the same territory.

Hence, a purposive interpretation must be followed in this regard, according to which Article 8(3) CTMR only applies to agreements which cover the territory of the EU, whether in whole or in part. In practice, this means that world-wide or pan-European agreements are covered by this provision, as are agreements extending to one or more Member States, or only covering part of their territory, irrespective of whether they also include third territories. Conversely, agreements exclusively applying to third territories are not covered.

4.1.4 Relevant points in time

The agent-representative relationship must have been established **prior to the filing date** of the CTM application. Therefore, it is immaterial whether after that time the applicant entered negotiations with the opponent, or made unilateral proposals with the purpose of becoming a representative or agent of the latter.

Case No	Comment
Decision of 19/05/2011, R 0085/2010-4 'Lingham's'	<p>The opponent granted the applicant a special power of attorney (PoA), consenting to the applicant's filing of trade mark applications. Subsequent to this PoA, the applicant filed a CTM. After the filing, the opponent revoked the PoA and filed the opposition.</p> <p>The Board considered that the relevant point in time is the filing date. At that moment, the owner's consent was present. The revocation had effects <i>ex nunc</i> (and does not affect the validity of actions performed under the PoA) and not <i>ex tunc</i> (as if the PoA had never existed) (para. 24).</p>
Judgment of 06/09/2006, T-6/05 'FIRST DEFENSE' (I)	The Board of Appeal ought to have examined whether, on the day of the application for registration of the mark, the intervener was still bound by the consent (para. 50).

However, even if the agreement between the parties was formally concluded **after the filing date** of the application, it may still be possible to deduce from the evidence that the parties were already in some form of commercial co-operation before the signature of the relevant contract and that the applicant was already acting as the opponent's agent, representative, distributor or licensee.

On the other hand, the agreement between the parties **does not have to be technically still in force** when the application is filed. The reference to a filing made by an 'agent or representative' should not be understood as a formal requirement that must be present at the time the CTM application is filed. Article 8(3) also applies to **agreements that expired before the filing date of the CTM application**, provided that the time that has lapsed is of such duration that it can be reasonably assumed that

the obligation of trust and confidentiality was still present when the CTM application was filed (confirmed by judgment of 13/04/2011, T-262/09 'First Defense' (II), para. 65).

Article 8(3) CTMR and Article 6^{septies} of the Paris Convention do not protect a trade mark proprietor who is careless and makes no efforts to secure trade mark protection on its own. Post-contractual fiduciary obligations mean that none of the parties may use the termination of an agreement as a pretext for getting rid of its obligations, for example by terminating an agreement and immediately afterwards filing a trade mark. The rationale of Article 8(3) CTMR and Article 6^{septies} of the Paris Convention is to prevent a situation where a representative in country A of a principal who owns trade marks in country B, and who is meant to market the trade-marked goods and observe the interests of the latter in country A, uses the filing of a trade mark application in country A as a weapon against the principal, for example to force the principal to continue with the representative and to prevent him from entering the market in country A. This rationale likewise applies if an agreement exists but the representative terminates it to take advantage and file a trade mark for the same reasons. However, this does not create absolute rights for the principal to obtain trade mark protection in other countries. The mere fact that the principal holds a trade mark in country B does not give him an absolute right to obtain trade marks in all other countries; the trade marks registered in different countries are in principle independent from each other and may have different proprietors, in accordance with Article 6(3) of the Paris Convention. Article 6^{septies} of the Paris Convention is an exception to this principle and only to the extent that the contractual or de facto obligations of the parties involved justify this. Only to that extent is it justified that the ensuing CTM would 'belong' to the principal under Article 18 CTMR (decision of 19/11/2007, R 0073/2006-4 'Porter', para. 26).

This should be assessed on a case-by-case basis, and the decisive factor should be whether it is still possible for the applicant to take commercial advantage of its expired relationship with the trade mark proprietor by exploiting the know-how and contacts it acquired because of its position.

Case No	Comment
Decision of 19/11/2007, R 0073/2006-4 'Porter'	The contested application was not filed during the validity of the agreements between Gallant (owner of shares in Porter, the applicant) and Yoshida (opponent) which allowed Gallant to file a CTM, but nearly <u>one year</u> after the termination of the last agreement (para. 25). The Board noted that post-termination fiduciary obligations are not meant to last forever but for a certain transitional period after the termination of the agreement in which the parties may re-define their commercial strategies and concluded, inter alia, that any post-contractual relationship between Yoshida and Gallant was phased out at the time of the filing of the CTM (para. 27).
Decision of 21/02/2002, B 167 926 'AZONIC'	In this case, less than <u>three months</u> after the expiry of a contract relationship, such as a license agreement, is a period within which it was still considered that the fiduciary relationship between the parties exists and imposes on the applicant a duty of loyalty and confidence.

4.2 Application in the agent's name

According to Article 8(3) CTMR, the trade mark applied for shall not be registered where the agent or representative applies for registration thereof in its own name. It will usually be easy to assess whether this requirement has been fulfilled, by comparing

the name of the applicant with that of the person appearing in the evidence as the agent or representative of the proprietor.

However, there may be cases where the agent or representative will try to **circumvent** this provision by arranging for the application to be filed by a third person, whom it either controls, or with whom it has entered into some form of understanding to that effect. In such cases adopting a more flexible approach is justified. Therefore, if it is clear that because of the nature of the relationship between the person filing the application and the agent, the situation is effectively the same as if the application had been filed by the agent himself, it is still possible to apply Article 8(3) CTMR, notwithstanding the apparent discrepancy between the applicant's name and the name of the proprietor's agent.

Such a case could arise if the application is filed not in the name of the agent's company, but in the name of a natural person that **shares the same economic interests** as the agent, as for example its president, vice-president or legal representative. Given that in this case the agent or representative could still benefit from such a filing, it should be considered that the natural person is bound by the same limitations as the company.

Case No	Comment
Decision of 21/02/2002, B 167 926 'AZONIC'	The Opposition Division considered that, even though the CTM application was applied for in the name of the natural person Mr Costahaude instead of directly in the name of the legal person STYLE'N USA, INC., the situation was effectively the same as if it had been filed in the name of the legal person.
Decision of 28/05/2003, B 413 890 'CELLFOOD'	If it is clear that because of the nature of the relationship between the person filing the application and the agent, the situation is effectively the same as if the application had been filed by the agent himself, it is still possible to apply Article 8(3) CTMR, notwithstanding the apparent discrepancy between the applicant's name and the name of the owner's agent.

Moreover, if the person filing the contested application had also **signed the agency agreement** on behalf of the company, this would have to be considered a strong argument in favour of the application of Article 8(3) CTMR, since in such a case the applicant cannot possibly deny direct knowledge of the relevant prohibitions. Similarly, if an agency agreement contained a **clause** holding the management of the company personally responsible for the observance of the contractual obligations undertaken by the agent, this would also have to be considered a further indication that the filing of the application is covered by the prohibition of Article 8(3) CTMR.

Case No	Comment
Decision of 21/02/2002, B 167 926 'AZONIC'	<p>Bearing in mind the position of the authorised representative of the Licensee Company, the Office considered that despite the fact that the CTM application was made in the name of this natural person, the situation was effectively the same as if it had been filed by the legal person, i.e. the Licensee Company. The CTM application in the name of the former could have a direct effect on the latter due to their professional relationship, and, furthermore, the President or Vice-President of a company should be considered obliged by the same limitations as their company, or at least temporarily obliged in the case of the expiry of their professional relationship.</p> <p>This position is strengthened by the fact that in the present case there is a clause in the renewed agreement that establishes the licensor's immediate termination right in the case that '... control of STYLE'N (the licensee) is transferred and the management thereby changed', which shows that the management of the licensee company was also bound by the terms of the agreement.</p>

A similar case arises where the agent or the representative and the applicant are distinct legal entities, but the evidence shows that they are **controlled, managed or run** by the same natural person. For the reasons given above it is appropriate to 'lift the corporate veil' and apply Article 8(3) also to these cases.

4.3 Application without the proprietor's consent

Even though the absence of the proprietor's consent is a **necessary condition** for the application of Article 8(3), the **opponent does not have to submit evidence which shows that the agent was not permitted** to file the CTM application. A mere **statement** that the filing was made without its consent is generally **sufficient**. This is because the opponent cannot be expected to prove a 'negative' fact, such as the **absence** of consent. In these cases the **burden of proof is reversed** and it is up to the applicant to prove that the filing was authorised, or to give some other justification for its acts.

In view of the need to provide effective protection to the legitimate proprietor from unauthorised acts of its agents, the application of Article 8(3) should be denied only where the proprietor's consent is sufficiently **clear, specific and unconditional** (see, for example, judgment of 06/09/2006, T-6/05, 'First Defense' (I), para. 40).

Therefore, even if the proprietor has expressly authorised the filing of the CTM application, its consent cannot be considered sufficiently clear if it has not also explicitly specified that the application may be in the name of the agent.

Case No	Comment
Decision of 07/07/2003, R 336/2001-2 'GORDON and SMITH' (fig. mark)	'In view of its serious effect in extinguishing the exclusive rights of the proprietors of the trade marks in issue in the main proceedings (rights which enable them to control the initial marketing in the EEA), consent must be so expressed that an intention to renounce those rights is unequivocally demonstrated' (para. 18).

Likewise, even if the proprietor has expressly authorised the filing of a CTM application, its consent cannot be considered specific enough for the purposes of Article 8(3)

CTMR if there is no indication of the specific signs which the applicant has permission to file as Community trade marks.

It will be generally easier to assess whether the filing was authorised by the proprietor where the conditions under which an agent or representative may apply for a CTM application are adequately regulated by **contract**, or are given by other kinds of **direct evidence** (letters, written representations etc.). In most cases, such evidence will be sufficient to show whether the proprietor has given its express consent, or if the applicant has exceeded the limits of its authorisation.

In other cases a contract will either not exist or it will be inadequate on the subject. Although the wording of Article 8(3) is in principle broad enough to include cases of **tacit or implied consent**, such consent should only be inferred if the evidence is sufficiently clear as to the intentions of the proprietor. If the **evidence is completely silent** as to the existence of an express or implied authorisation, **lack of consent should be generally presumed**.

Notwithstanding **indirect indications** and evidence pointing to implied consent, any **ambiguity or doubt** should be **interpreted in favour of the opponent**, as it will usually be quite difficult to assess whether such consent is sufficiently clear and unequivocal.

For example, the mere fact that the proprietor tolerated unauthorised applications in the name of the agent in third jurisdictions cannot alone create legitimate expectations on the part of the applicant that the proprietor will not object to the filing of a CTM application either.

Case No	Comment
Decision of 31/01/2001, B 140 006 'GORDON and SMITH' (fig. mark) (confirmed by decision of 07/07/2003, R 336/2001-2)	The mere fact that the opponents failed to immediately oppose the applicant's action to register the trade mark after they received notice of the fact did not constitute consent.

The fact that the proprietor tolerates conduct outside the boundaries of a contract (such as use of the sign) cannot lead to the conclusion that filing the CTM did not breach the established fiduciary duty if consent is not clear, specific and unconditional.

Case No	Comment
<p>Joined cases T-537/10 and T-538/10, 'FAGUMIT'</p>	<p>The applicant (the CTM owner in cancellation proceedings) focused her line of argument on the consent allegedly granted by the proprietor of the mark. The Court held (like the Board of Appeal) that the consent for the purposes of the registration of the mark in the name of the representative or agent must be clear, specific and unconditional (paras 22-23).</p> <p>The document relied upon by the CTM owner does not show consent within the meaning of Article 8(3) CTMR (para. 28). The CTM owner was not mentioned in the document and it did not refer to the possibility of registration of the sign as a trade mark. The CTM owner cannot rely on the fact that the cancellation applicant did not object to the use of the sign by companies other than those referred to in the document. Use of the marks occurred during the course of marketing the goods produced by the cancellation applicant. However, such use is the logical consequence of the cooperation between the cancellation applicant and the distributors of its goods and does not show any abandonment of the sign, which would enable anyone to make an application for the registration of that sign – or its dominant element – as a CTM (para. 27)</p>

Even where consent of the proprietor has been deemed to be clear, specific and unconditional, it will be a question of fact to determine if such consent survives a **change of proprietor** by way of an asset sale.

Case No	Comment
<p>Judgment of 06/09/2006, T-6/05, 'FIRST DEFENSE' (I)</p>	<p>The General Court remitted a case of this nature back to the Board of Appeal in order to determine whether the consent obtained by the CTM applicant had survived the purchase of the assets of the former trade mark holder and whether, on the day of the application for registration of the mark, the new holder of the trade mark in the USA (the opponent) was <u>still bound</u> by that consent.</p> <p>If the opponent was no longer bound by the consent, the GC indicated that the Board ought then to determine whether the applicant had a <u>valid justification</u> which could offset the lack of such consent.</p>

4.4 Absence of justification on the part of the applicant

As mentioned above, since it is not possible for the opponent to prove the absence of consent, the burden of proof is reversed and it is up to the applicant to show that the filing of the application was authorised by the proprietor. Although Article 8(3) CTMR treats the lack of the proprietor's consent and the absence of a valid justification on the part of the applicant as two separate conditions, these requirements largely overlap to the extent that if the applicant establishes that the filing of the application was based on some agreement or understanding to this effect, then it will have also provided a valid justification for its acts.

In addition, the applicant may invoke any other kind of circumstance showing that it was justified to file the CTM application in its own name. However, in the absence of evidence of direct consent, only exceptional reasons are accepted as valid justifications, in view of the need to avoid a violation of the proprietor's legitimate

interests without sufficient indications that its intention was to allow the agent to file the application in its own name.

For example, it could be possible to infer that the proprietor has tacitly consented to the filing of the application if it does not react within a reasonable period of time after having been informed by the applicant that it intends to apply for a CTM in its own name. However, even in such a case it will not be possible to assume that the application has been authorised by the proprietor if the agent had not made it sufficiently clear to the proprietor in advance in whose name it would file the application.

Another case of valid justification could be if the proprietor causes its agent to believe that it has abandoned the mark, or that it is not interested in obtaining or maintaining any rights in the territory concerned, for example by suspending the use of the mark over a relatively long period of time.

The fact that the proprietor does not want to spend money on a registration of its trade mark does not give the agent a right to act on its own initiative, as the proprietor might still have an interest in using its trade mark in the territory although it is not registered. Such a business decision cannot be taken in itself as a sign that the proprietor has given up the rights in its mark.

Justifications exclusively linked to applicant's economic interests, such as the need to protect its investment in setting up a local distribution network and promoting the mark in the relevant territory, cannot be considered valid for the purposes of Article 8(3) CTMR.

Nor can the applicant successfully argue in its defence that it is entitled to some financial remuneration for its efforts and expenditure in building-up goodwill for the mark. Even if such remuneration were well deserved or is expressly stipulated in the agency agreement, the applicant cannot use the registration of the mark in its own name as a means of extracting money from the opponent or in lieu of financial compensation, but should try to settle its dispute with the proprietor either by way of agreement or by suing for damages.

Finally, if the applicant does not provide any justification for its actions, it is not for the Office to make any speculations in that regard (see judgment of 09/07/2014, T-184/12 'Heatstrip', paras 73 and 74).

Case No	Comment
Decision of 04/10/2011, 4443 C, 'CELLO'	As to the justificatory argument that the CTM application was filed in order to protect the goodwill of the mark in the EU, which had been established solely as a result of its trading activities, the Cancellation Division considered that the fact that a distributor, exclusive or otherwise, develops the goodwill of the trade mark of the owner in its allocated territory forms part of the usual duties of a distributor and cannot constitute, in itself and in the absence of other circumstances, a valid justification for the appropriation of the owner's mark by the distributor.

Case No	Comment
Decision of 10/01/2011, 3253 C, 'MUSASHI' (fig. mark)	As regards justification concerning economic claims of the party filing the CTM and its arguments that it is entitled to some financial remuneration for permitting the sign to enjoy protection at EU level, and that it could be transferred to the Cancellation applicant, it was held that this could not be valid justification within the meaning of Article 8(3). 'Even if remuneration were well deserved, the CTM proprietor cannot use the registration of a mark in its own name as a means of receiving payment' (from the Cancellation applicant) (para. 47).
Decision of 07/07/2003, R 336/2001-2 'GORDON and SMITH' (fig. mark)	An act which compromises the interests of the trade mark proprietor, such as the filing of a trade mark application in the agent's or a representative's name without the proprietor's consent, and is driven solely by an intention to safeguard the agent's or a representative's own interests, is not considered justifiable for the purposes of Article 8(3) CTMR. The same applies to the applicant's second argument, that is, that it was justified in doing so because it bore the registration costs. The interests of the trade mark proprietor cannot be subordinate to an agent's or a representative's financial expenses. The fact that an opponent might be unwilling to incur any financial expenses to register a trade mark does not automatically grant a right to the agent or representative to proceed with the registration of the trade mark in its own name. This would constitute a violation of the agent's or representative's duty of trust and loyalty towards the trade mark proprietor (para. 24).

4.5 Applicability beyond identical signs – goods and services

Article 8(3) CTMR provides that a CTM application will not be registered where 'an agent or representative of the proprietor of the mark applies for registration thereof in his own name'. Such an explicit reference to the principal's trade mark gives the prima facie impression that the CTM applied for must be the same as the earlier mark.

Hence, a literal interpretation of Article 8(3) CTMR would lead to the conclusion that its application is only possible where the agent or representative intends to register a mark identical to that of the proprietor.

Moreover, the text of Article 8(3) CTMR does not refer to the goods and services for which the application has been filed and for which the earlier mark is protected and, thus, gives no guidance as to what the exact relationship between the respective goods and services should be for the article to apply.











However, applying Article 8(3) CTMR exclusively to identical signs for identical goods or services would render this provision largely ineffective, as it would allow the applicant to escape its consequences by merely making slight modifications either to the earlier mark or to the specification of goods and services. In such a case, the proprietor's interests would be seriously prejudiced, especially if the earlier mark were already in use and the variations made by the applicant were not significant enough to rule out confusion. What is more, if the application were allowed to proceed to registration despite its similarity to the earlier mark, the applicant would be in a position to prevent any subsequent registration and/or use of the earlier mark by the original proprietor within the EU, by relying on Articles 8(1) or 9(1) CTMR, or the equivalent provisions of national law.

To sum up, in view of the need to effectively protect the legitimate proprietor against unfair practices by its representatives, a restrictive interpretation of Article 8(3) CTMR

must be avoided. Therefore, Article 8(3) CTMR must be applied not only where the respective **marks are identical, but also:**

- when the sign applied for by the representative or agent essentially reproduces the earlier mark with slight modifications, additions or deletions, which do not substantially affect its distinctiveness; and
- when the goods and services in conflict are closely related or equivalent in commercial terms. In other words, what finally counts is that the goods or services of the applicant may be perceived by the public as 'authorised' products, the quality of which is still somehow 'guaranteed' by the opponent, and which it would have been reasonable for the opponent to market in view of the goods and services protected under the earlier mark.

The following are examples of conflicting **signs** where the Office considered that Article 8(3) CTMR is applicable:

Earlier mark	CTM application	Case No
<p>FIRST DEFENSE</p>  <p>(2 US earlier rights)</p>		<p>Decision of 04/05/2009, R 0493/2002-4, 'First Defense' (II)</p> <p>Judgment of 13/04/2011, T-262/09, 'FIRST DEFENSE' (II)</p>
		<p>Decision of 03/05/2012, R 1642/2011-2 'Maritime Acopafi' (fig. mark)</p>
 <p>BERIK (word mark) (2 earlier rights)</p>		<p>Decision of 03/08/2010, R 1367/2009-2 'BERIK DESIGN' (fig. mark)</p>
 <p>BERIK (word mark) (2 earlier rights)</p>		<p>Decision of 03/08/2010, R 1231/2009-2 'BERIK' (fig. mark)</p>
	<p>NORAXON</p>	<p>Decision of 19/06/1999, B 3 436 'NORAXON'</p>
	<p>APEX</p>	<p>Decisions of 26/09/2001, B 150 955 and B 170 789, 'APEX'</p>

The following are examples of **goods and services** in conflict where the Office considered that Article 8(3) CTMR is applicable:

Case No	Comment
<p>Decision of 04/05/2009, R 0493/2002-4 – ‘FIRST DEFENSE’ (II)</p>	<p>The Board held that the contested <i>disabling sprays</i> in Class 13 were covered by the proprietor’s <i>non-explosive defense weapons in the nature of an organic irritant packaged in an aerosol (or pressurized spray) canister</i>.</p> <p>However, it considered that protection did not extend to the contested <i>side arms, ammunition, projectiles</i>. These are goods for which commercial activity from the proprietor cannot be reasonably expected. Side arms and ammunition are far too different from pepper sprays to be covered by Article 8(3) CTMR given that the opponent markets a very specific product (paras 19 to 24).</p> <p>In its judgment of 13/04/2011, T-262/09, the GC did not examine the arguments of the parties regarding the similarity of the goods.</p>
<p>Decision of 03/05/2012, R 1642/2011-2 ‘Maritime Acopafi’ (fig. mark)</p>	<p>The Board held that the wording suggests only if the mark applied for is essentially identical to the earlier right, in terms of both signs and goods/services, it can be prohibited. On the other hand, a too-literal reading of that provision would fatally weaken its utility by allowing fraudulent agents to register their principals’ marks by merely making minor modifications or unimportant additions to them. Despite these considerations, however, the provision must apply only where the signs and the goods/services are essentially the same, or largely equivalent (para. 18).</p> <p>In view of this, the Board upheld OD’s findings that the earlier mark’s use for <i>installation of marine accommodation</i> was fundamentally different from the applicant’s services in Class 42 (<i>scientific and technological services and research and design relating thereto; industrial analysis and research services; design and development of computer hardware and software</i>).</p>
<p>Decision of 03/08/2010, R 1367/2009-2 ‘Berik’ (fig. mark)</p>	<p>The Board agreed with the Cancellation Division that the cancellation applicant’s goods in Class 25 could not be considered closely related or equivalent in commercial terms to the applicant’s goods in Class 18, <i>leather or imitation leather</i>. The latter are raw materials for producers of goods made of leather or imitation of leather and, thus, target a different public and have different distribution channels from the goods covered by the cancellation applicant’s marks (paras 30 and 31).</p> <p>It further agreed with the Cancellation Division that the cancellation applicant’s goods in Class 25 could not be considered closely related or equivalent in commercial terms to the applicant’s goods in Class 16 even if, for example, some of the contested goods could be used as merchandising items for a line of clothing (paras 28-30).</p>

Case No	Comment
<p>Decision of 27/02/2012, B 1 302 530 'GEOWEB / NEOWEB'</p>	<p>'In view of the necessity to effectively protect the legitimate proprietor against unfair practices by its representatives, a restrictive interpretation of Article 8(3) CTMR must be a voided. Therefore, this provision must be applied not only where the respective marks are identical, but also where the mark applied for by the representative or agent essentially reproduces the earlier mark with slight modifications, additions or deletions, which do not substantially affect its distinctiveness.</p> <p>In line with the aforementioned reasoning, Article 8(3) CTMR does not only cover cases where the respective lists of goods and services are strictly identical, but it also applies where the goods and services in conflict are closely related or equivalent in commercial terms. In other words, what finally counts is that the goods or services of the applicant may be perceived by the public as 'authorised' products, the quality of which is still somehow "guaranteed" by the opponent' (p. 20).</p>

***GUIDELINES FOR EXAMINATION IN THE
OFFICE FOR HARMONIZATION IN THE
INTERNAL MARKET (TRADE MARKS AND
DESIGNS) ON COMMUNITY TRADE MARKS***

PART C

OPPOSITION

SECTION 4

RIGHTS UNDER ARTICLE 8(4) CTMR

Table of Contents

1	Introduction.....	3
2	Structure of Article 8(4) CTMR	3
3	Conditions of Article 8(4) CTMR.....	5
3.1	Direct right conferred on the opponent	5
3.2	Types of rights falling under Article 8(4) CTMR	6
3.2.1	Introduction	6
3.2.2	Non-registered trade marks.....	6
3.2.3	Other business identifiers	7
3.2.3.1	Trade names	8
3.2.3.2	Corporate names.....	8
3.2.3.3	Domain names	9
3.2.3.4	Titles.....	9
3.2.4	Geographical indications	10
3.2.4.1	Earlier rights deriving from EU legislation.....	10
3.2.4.2	Earlier rights deriving from the laws of Member States	11
3.2.4.3	Earlier rights deriving from international agreements	12
3.2.4.4	Scope of protection of PGIs.....	13
3.3	Use requirements	15
3.3.1	National Standard.....	15
3.3.2	European Standard – use in the course of trade of more than mere local significance	15
3.3.2.1	Use in the course of trade	16
3.3.2.2	Significance of the use	19
3.4	Earlier right	24
3.5	Scope of protection.....	25
4	Proof of the Applicable Law Governing the Sign.....	25
4.1	The burden of proof	25
4.2	Means of evidence and standard of proof	27
4.2.1	National law	27
4.2.2	European Union law	29
 TABLE ON NATIONAL RIGHTS THAT CONSTITUTE ‘EARLIER RIGHTS’ IN THE SENSE OF ARTICLE 8(4) CTMR		 30

1 Introduction

The relationship between the Community Trade Mark system and national law is characterised by the *principle of coexistence*. This means that both the Community Trade Mark system and the national laws exist and operate side by side. The same sign can be protected by the same proprietor as a CTM and as a national trade mark in one (or all) of the Member States. The *principle of coexistence* further implies that the CTM system actively acknowledges the relevance of national rights and their scope of protection. Where conflicts arise between CTMs and national trade marks or other national rights, there is no hierarchy determining that one system prevails over the other; instead, these conflicts apply the principle of priority. If the respective requirements are met, earlier national trade marks or other earlier national rights can prevent registration of, or invalidate a later CTM.

Although the TM Directive and its subsequent implementation have harmonised the laws relating to *registered trade marks*, no such harmonisation has taken place on an EU scale with regard to *non-registered trade marks* nor for most *other earlier rights* of a similar nature. These un-harmonised rights remain completely governed by national laws.

The types of earlier rights which can be relied upon in proceedings before the Office are specified in the CTMR under:

- Article 8(4) CTMR, which restricts the scope of protection in *opposition proceedings* to earlier **non-registered trade marks and other signs used in the course of trade of more than mere local significance**;
- Article 53(2)(a)-(d) CTMR, which broadens the scope of possible earlier rights to be relied upon for *invalidity proceedings* beyond those of Article 8(4) CTMR to also cover other earlier rights, in particular the right to a name, the right of personal portrayal, a copyright and an industrial property right;
- Article 111 CTMR, which complements the range of earlier rights to be relied upon in opposition proceedings by providing that rights which are only valid in particular localities and, thus, do not meet the ‘more than mere local significance’ criterion of Article 8(4) CTMR, can oppose use of a CTM even though these local rights cannot impede its registration.

This part of the Guidelines only deals with the earlier rights falling under Article 8(4) CTMR.

2 Structure of Article 8(4) CTMR

Article 8(4) CTMR reads:

Upon opposition by the **proprietor of a non-registered trade mark or of another sign used in the course of trade of more than mere local significance**, the trade mark applied for shall not be registered where and to the extent that, pursuant to the law of the Member State governing that sign:

- (a) rights to that sign were **acquired prior** to the date of application for registration of the Community trade mark, or the date of the priority claimed for the application for registration of the Community trade mark;
- (b) that sign confers on its proprietor the **right to prohibit the use of a subsequent trade mark**.

Article 8(4) CTMR means that in addition to the earlier trade marks specified in Article 8(2) CTMR, non-registered trade marks and other signs protected at Member State level used in the course of trade as 'business identifiers' of more than mere local significance can be invoked in an opposition provided that such rights confer on their proprietors the right to prohibit the use of a subsequent trade mark.

Article 8(4) CTMR does not expressly or exhaustively enumerate the particular rights which can be invoked under this provision, but rather outlines a broad spectrum of rights that might serve as basis for an opposition against a CTM application. Therefore, Article 8(4) CTMR can be regarded as a general 'catch-all-provision' for oppositions based on non-registered trade marks and other signs used in the course of trade.

Nevertheless, the broad scope of earlier rights to be relied upon in opposition proceedings under Article 8(4) CTMR is subject to a number of restrictive conditions: these rights must confer an entitlement to the proprietor to exercise them, they must be of more than local significance, they must be protected by the national law governing them against the use of a subsequent trade mark and the rights must have been acquired prior to the CTMA under the law of the Member State governing that sign.

The 'more than mere local significance' requirement aims at restricting the number of potential opposing non-registered rights, thus avoiding the risk of a collapse or paralysis of the CTM system by being flooded with opposing, relatively insignificant rights.

The 'national protection' requirement is deemed necessary as the non-registered national rights are not easily identifiable and their protection is not harmonised on an EU level. Consequently, only national law governing the earlier signs may define the scope of their protection.

While the requirements of 'use in the course of trade' and 'use of more than mere local significance' are to be interpreted in the context of Community law (European standard), national law applies when determining whether a particular right is recognised and protected under the national law, whether its holder is entitled to prohibit the use of a subsequent trade mark, and what conditions need to be met under national law for the right to be successfully exercised.

As a consequence of this dualism, the Office must apply both the relevant provisions of the CTMR and the national law governing the earlier opposing right. In view of the two-tier examination to be applied under Article 8(4) CTMR, this provision, as the link between Community and national law, displays a somewhat 'hybrid' nature.

3 Conditions of Article 8(4) CTMR

The conditions for successfully invoking Article 8(4) CTMR are:

- a) the opponent must be the beneficiary of a non-registered trade mark or of another sign used in the course of trade;
- b) use of more than mere local significance;
- c) acquisition prior to the CTMA under the law of the Member State governing that sign;
- d) right to prohibit the use of a subsequent trade mark under the law of the Member State governing that sign.

3.1 Direct right conferred on the opponent

The legal systems of the EU Member States provide various means of preventing the use of later marks on the basis of earlier signs used in the course of trade. However, in order to come within the meaning of Article 8(4) CTMR, the earlier right must be vested in a particular owner or a precise class of user that has a **quasi-proprietary interest** over it, in the sense that it can exclude or prevent others from unlawfully using the sign. This is because Article 8(4) CTMR is a 'relative' ground for opposition and Article 41(1)(c) CTMR provides that oppositions may be filed only by the proprietors of earlier marks or signs referred to in Article 8(4) CMTR and by persons authorised under the relevant national law to exercise these rights. In other words, only persons having an interest directly recognised by law in initiating proceedings are entitled to file an opposition within the meaning of Article 8(4) CTMR.

For example, in some Member States, the use of a sign may be prohibited if it results in unfair or misleading business practices. In such cases, if the earlier right lacks any 'proprietary quality', it will not fall within Article 8(4) CTMR. It does not matter whether these signs are protected against misleading or unfair use under trade mark law, the law relating to unfair competition, or any other set of provisions. An example in this respect is the German Regulation governing the use of the geographical indication 'Solingen' for specific goods (cutlery scissors, knives etc.). This law would not be a proper basis for an opposition under Article 8(4) CTMR because the sign in question lacks any proprietary quality and, as such, is more public in nature.

Earlier right	Case No
A.O. CUBA	R0051/2007-4
Where the national law does not confer on a legal entity (whether public or private) a subjective right allowing it to prohibit the use of a subsequent trade mark, the "proprietary requirement" is not met. The Board found that the Spanish law giving effect to the bilateral Agreement between Spain and Cuba for the protection of the appellation of origin "Cuba" was not sufficient to grant such a subjective right (para. 23-27).	

In assessing the proprietorship of a sign used in the course of trade, the Office must analyse specifically whether the opponent has acquired rights over the sign 'in accordance with the national law' (judgment of 18/01/2012, T-304/09, 'Basmati').

3.2 Types of rights falling under Article 8(4) CTMR

3.2.1 Introduction

When assessing which kind of intellectual property rights can be invoked under Article 8(4) CTMR and which cannot, a European standard applies. The distinction follows from the scheme of the CTMR and, in particular, from the differentiation made between the kinds of earlier signs upon which an opposition may be based under Article 8(4) CTMR and the types of further rights that may be the basis for invalidity under Article 53(2) CTMR. While Article 8(4) CTMR refers to *signs* ('non-registered trade mark or ... another sign'), Article 53(2) CTMR refers to a broader set of rights: (a) a right to a name; (b) a right of personal portrayal; (c) a copyright; and (d) an industrial property right.

Therefore, although the signs covered by Article 8(4) CTMR fall within the broad category of 'industrial property rights', not all industrial property rights are 'signs' for the purposes of Article 8(4) CTMR. Since this distinction is contained in the CTMR, the classification of a right under the respective national law is not decisive, and it is immaterial whether the national law governing the respective sign or industrial property right treats both types of rights in one and the same law.

The types of rights falling under Article 8(4) CTMR are:

- 'non-registered trade marks'; and
- 'other signs used in the course of trade' which cover:
 - business identifiers such as:
 - trade names;
 - corporate names;
 - establishment names;
 - titles of publications or similar works;
 - domain names;
 - geographical indications.

Most national business identifiers falling within the category of earlier rights within the meaning of Article 8(4) CTMR will be non-registered signs. However, the fact that a sign is also registered in accordance with the requirements of the respective national law does not bar it from being invoked under Article 8(4) CTMR.

3.2.2 Non-registered trade marks

Non-registered use-based trade marks exist in a number of the Member States¹ (see the Table at the end of the document for an overview) and are signs that indicate the commercial origin of a product or service. Therefore, they are signs which function as a trade mark. The rules and conditions governing acquisition of rights under the relevant

¹ Benelux, Cyprus, Croatia, Estonia, France, Lithuania, Poland, Romania, Slovenia and Spain do not protect unregistered trade marks (unless, for some jurisdictions, they are considered well-known within the meaning of Article 6bis of the Paris Convention).

national law vary from simple use to use having acquired a reputation. Neither is their scope of protection uniform, although it is generally quite similar to the scope of protection under the provisions in the CTMR concerning registered trade marks.

Article 8(4) CTMR reflects the existence of such rights in Member States and grants the proprietors of non-registered marks the possibility of preventing the registration of a CTMA where they would succeed in preventing use of that CTMA under the relevant national law, by showing that the conditions set by the national law for prohibiting use of the later CTM are satisfied and the other conditions of Article 8(4) CTMR are met.

Example: R 1529/2010-1 'Gladiator', where a non-registered trade mark in the Czech Republic was invoked and R 1446/2006-4 'RM2007', where a non-registered trade mark in Belgium was invoked and the opposition rejected as unfounded because non-registered trade marks are not protected in Belgium.

3.2.3 Other business identifiers

'Other signs used in the course of trade' is a broad category that is not enumerated in Article 8(4) CTMR. In order for such signs to come within the ambit of Article 8(4) CTMR, they must have an identifying function, that is, they must primarily serve to identify in trade a business (business identifiers) or a geographical origin (geographical indications). Article 8(4) CTMR does not cover other types of intellectual property rights that are not 'commercial signs' – such as patents, copyrights or design rights which do not have a primarily identifying function but which protect technical or artistic achievements or the 'appearance' of something.

Some examples of cases dealing with whether a right is a 'sign' for the purposes of Article 8(4) CTMR are set out below.

Earlier right	Case No
JOSE PADILLA (copyright)	T-255/08
The Court found that copyright cannot constitute a 'sign used in the course of trade' within the meaning of Article 8(4) CTMR. It is apparent from the scheme of Article 53 CTMR that copyright is not such a sign. Article 53(1)(c) CTMR provides that a Community trade mark is to be declared invalid where there is an earlier right as referred to in Article 8(4) CTMR and the conditions set out in that paragraph are fulfilled. Article 53(2)(c) CTMR provides that a Community trade mark is also to be declared invalid where the use of such a trade mark may be prohibited pursuant to any 'other' earlier right and in particular a copyright. <u>It follows that copyright is not one of the earlier rights referred to in Article 8(4) CTMR.</u>	

Earlier right	Case No
Dr. No (copyright)	T-435/05
In addition, it is clear from Article 8(4) CTMR read in conjunction with Article 53(2) CTMR that the protection provided for by <u>copyright cannot be relied on in opposition proceedings</u> , but only in proceedings for a declaration of invalidity of the Community mark in question (para. 41).	

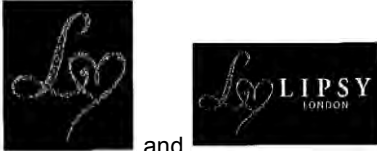
Earlier rights	Case No
 <p data-bbox="395 456 627 488">(Community designs)</p>	B 1 530 875
<p>Designs are a form of intellectual property dealing with the ornamental or aesthetic aspects of an article's appearance. Designs are deemed to be the result of a creative work which needs to be protected against unauthorised copying or imitation by third parties in order to ensure a fair return on investment. <u>They are protected as intellectual property, but they are not business identifiers or trade signs. Therefore, designs do not qualify as signs used in the course of trade for the purpose of Article 8(4) CTMR.</u></p>	

3.2.3.1 Trade names

Trade names are the names used to identify businesses, as distinguished from trade marks which identify goods or services as produced or marketed by a particular undertaking.

A trade name is not necessarily identical with the corporate name or commercial name entered in a commercial or similar register as trade names can cover other non-registered names such as a sign which identifies and distinguishes a certain establishment. Trade names are protected as exclusive rights in all Member States.

Pursuant to Article 8 of the Paris Convention, trade names enjoy protection without any registration requirement. If national legislation requires registration for national trade names, the respective provision is not applicable by virtue of Article 8 of the Paris Convention with respect to trade names held by a national of another Contracting Party to the Paris Convention. This applies as well in respect of nationals of a member of the WTO Agreement.

As regards the application of Article 8(4) CTMR to trade names, where the trade name is invoked on the basis of the law of one of the Member States where a registration is a condition for the enforcement of rights in a trade name, the Office will apply this requirement where the Member State and the nationality of the opponent are the same, but will not apply this requirement in all other cases, since this would violate the provisions of Article 8 of the Paris Convention.

Examples: R 1714/2010-4 where the Spanish trade name 'JAMON DE HUELVA' was invoked.

3.2.3.2 Corporate names

A corporate name or company name is the official designation of an undertaking, in most cases registered in the respective national commercial register.

Article 8(4) CTMR requires that actual use be shown, even if national law vests in the holder of such a name the right to prohibit the use of a subsequent trade mark on the basis of registration alone. However, if under national law registration is a prerequisite for protection, registration must be shown as well. Otherwise, there would be no

national right that the opponent could invoke.

Examples: judgment of 14/09/2011, T-485/07, 'O-live (fig.)' where the Spanish commercial name 'OLIVE LINE' was invoked and R 0021/2011-1 where the French company name 'MARIONNAUD PERFUMERIES' was invoked.

3.2.3.3 Domain names

A domain name is a combination of typographical characters corresponding to one or several numeric IP addresses that are used to identify a particular web page or set of web pages on the internet. As such, a domain name functions as an 'address' used to refer to a specific location on the internet (oami.europa.eu) or an email address (@oami.europa.eu).

Domain names are registered with organisations or commercial entities called 'domain name registrars'. Although a domain name is unique and may be a valuable commercial asset, a domain name registration per se is not an intellectual property right. Such registrations do not create any form of exclusive right. Instead, 'registration' in this context refers to a contractual agreement between a domain name registrant and the domain name registrar.

However, the *use* of a domain name may give rise to rights that can be the basis for an opposition under Article 8(4) CTMR. This can occur if the use of the domain name means that it is protected as a non-registered trade mark or a business identifier under the applicable national law.

Examples: R 0275/2011-1, where rights based on the use of the German domain name 'lucky-pet.de' were invoked; B 1 719 379, where rights based on the use of the French domain name 'Helloresto.fr' were invoked; T-321/11 and T-322/11, where rights based on the use of the Italian domain name 'partidodellaliberta.it' were invoked and the Court considered that references to this site in the Italian press did not in themselves substantiate its use in the context of a commercial activity.

3.2.3.4 Titles

Titles of magazines and other publications, or titles of similar categories of works such as films, television series, etc. fall under Article 8(4) CTMR only if, under the applicable national law, they are protected as business identifiers.

The fact that the copyright in a title of a work can be invoked under the respective national law against a subsequent trade mark is not material for the purposes of Article 8(4) CTMR. As set out above, whilst a right in copyright may be used to invalidate a CTM under Article 53(2) CTMR, it is only where a title has an 'identifying' function and acts as a business identifier that it comes within the scope of Article 8(4) CTMR. Therefore, for such signs to be relied on under Article 8(4) CTMR in the context of opposition proceedings, the national law must foresee a protection which is independent from that recognised by copyright law (judgment of 30/06/2009, T-435/05, 'Dr. No', paras. 41-43.)

As with all rights under Article 8(4), the title must have been used in the course of trade. This will normally require that the work to which the title relates must have been placed on the market. Where the title relates to a service (such as a television

programme), that service must have been made available. However, there will be circumstances where pre-use advertising may be sufficient to create rights, and where such advertising will constitute ‘use’ within the meaning of Article 8(4) CTMR. In all cases, the title must have been used as an indicator of the commercial origin of the goods and services in question. Where a title is used only to indicate the artistic origin of a work, such use falls outside the scope of Article 8(4) CTMR (judgment of 30/06/2009, T-435/05, ‘Dr. No’, 25-31).

Example: R 0181/2011-1 where the magazine title ‘ART’ was invoked.

3.2.4 Geographical indications

Geographical indications are used to designate the origin of goods as being from a particular region or locality. For a general overview on geographical indications see the Guidelines, Part B: Examination, Section 4 Absolute Grounds for Refusal and Community Collective Trade Marks, paragraph 2.09 on Article 7(1)(j) CTMR and paragraph 2.10 on Article 7(1)(k) CTMR.

Depending on the context, as described below, the term ‘protected geographical indication’ (PGI) may cover terms such as ‘designations of origin’, ‘appellations of origin’ and equivalent terms, and is used in this chapter to refer to PGIs in general.

PGIs are protected in various ways in the EU (national law, EU law, international agreements) and cover various product areas (such as foodstuffs or handicrafts).

This section identifies the types of PGIs that may serve as a valid basis for oppositions under Article 8(4) CTMR.

3.2.4.1 Earlier rights deriving from EU legislation

At EU level, there is protection for PGIs for the following categories of products:

1. **certain foodstuffs and certain non-food agricultural products** (pursuant to Regulation No 1151/2012², the ‘Foodstuffs Regulation’);
2. **wines and sparkling wines** (pursuant to Regulation No 1308/2013³, the ‘Wines Regulation’); and
3. **spirits** (pursuant to Regulation No 110/2008⁴, the ‘Spirits Regulation’).

The nature of the indications covered is broadly the same albeit that the precise definition of terms varies according to the legislation. Earlier rights that are registered or applied for as PGIs under the above regulations (which can even include PGIs from third countries), can constitute a ‘sign used in the course of trade’ under Article 8(4) CTMR and may be a valid basis for an opposition to the extent that they allow the proprietor **to prevent use** of a subsequent mark. Their ability to prevent use is

² Replaced and repealed Regulation No 510/2006 which had replaced and repealed Regulation No 2081/92.

³ Replaced and repealed Regulation No 1234/2007 which had integrated, through codification by Regulation No 491/2009, Regulation No 479/2008 which was repealed at the same time.

⁴ Replaced and repealed Regulation No 1576/89.

governed by the relevant provisions of the Regulations cited above (Article 13, Article 103(2) and Article 16 of the Foodstuffs, Wines and Spirits Regulations respectively). In this context, it is important to distinguish the latter provisions preventing use from those that prevent registration⁵ of a trade mark, which are not a basis for opposition under Article 8(4) CTMR.

In order to substantiate its right, the opponent must provide the Office with the necessary facts and evidence regarding the existence of its right. A mere extract of the relevant online EU databases (DOOR, E-Bacchus or E-Spirit-Drinks) or in the case of spirits, an extract of Annex III of the Spirits Regulation, is not sufficient, as they do not contain sufficient data to determine all the relevant particulars of the earlier right (e.g. entitlement of the opponent or goods protected by the PGI).

The opponent must in any event provide the Office with **copies of the publication and registration of the PGI in the Official Journal** and, if these documents lack information on the opponent's entitlement, further documents proving its entitlement to file the opposition as **proprietor or person authorised under the relevant national law to exercise the right** (Article 41(1)(c) CTMR and Rule 19(2) CTMIR). See in this respect decision of 17/10/2013, R1825/2012-4 'Dresdner StriezelGlühwein/Desdner Stollen' para. 37).

The EU system of protection of PGIs for foodstuffs, wines and spirits is **exhaustive in nature and supersedes national protection** for those goods. This arises from the findings of the Court in the judgment of 08/09/2009, C-478/07 'BUD', paras. 95-129. Here the Court held that the aim of Regulation No 510/2006 (the predecessor of the current Foodstuffs Regulation) was to provide a uniform and exclusive system of protection of PGIs for agricultural products and foodstuffs that superseded national laws for the relevant products⁶. Although the Court has not specifically pronounced upon the exhaustive nature of the Wines and Spirits Regulations, the same principle must apply because they contain substantively similar provisions to the Foodstuffs Regulation and they have the same purpose for the respective products.

3.2.4.2 Earlier rights deriving from the laws of Member States

Certain PGIs deriving from the laws of Member States may be a basis for opposition under Article 8(4) CTMR. Nevertheless, for the reasons set out above, in the areas of foodstuffs, wines and spirits protection at EU level is exhaustive in nature which means that an opposition under Article 8(4) CTMR cannot be based on national rights in these areas. This is because the EU system of protection comprising the above regulations **overrides and replaces** national protection of PGIs for foodstuffs, wines and spirits.

Consequently, PGIs for certain foodstuffs⁷ and certain non-food agricultural products⁸ (as set out in Annex I of the Treaty on the Functioning of the European Union (TFEU) and Annex I of the Foodstuffs Regulation), wines and grapevine products⁹ (as set out

⁵ Articles 14, 102 and 23 of the Foodstuffs, Wines and Spirits Regulations respectively.

⁶ For additional information, see the Guidelines, Part B: Examination, Section 4 Absolute Grounds for Refusal and Community Collective Trade Marks, paragraph 2.09 on Article 7(1)(j) CTMR and paragraph 2.10 on Article 7(1)(k) CTMR.

⁷ e.g. *meat, cheese, pastry, edible oils, vegetables, fruits, beverages made from plant extracts, vinegar (including wine vinegar), unmanufactured tobacco, beer, confectionery.*

⁸ e.g. *wool, leather, essential oils.*

⁹ e.g. *wine, sparkling wine, liqueur wine, wine must, but not wine vinegar.*

in Annex VII, part 2 of the Wines Regulation) and spirit drinks¹⁰ (as set out in Annex II of the Spirits Regulation) that are protected under national laws are not a proper ground of opposition under Article 8(4) CTMR. For the latter products, the opponent *must* invoke the relevant *EU* legislation in the notice of opposition.

Nevertheless, **where no uniform EU protection is in place for a category of goods** (e.g. *handicrafts*), PGIs that are protected under national laws can be a basis for opposition under Article 8(4) CTMR (e.g. ČESKÝ PORCELÁN / FINE BOHEMIAN CHINA for crystal ware).

3.2.4.3 Earlier rights deriving from international agreements

In order for an opposition under Article 8(4) CTMR to be successful on the basis of a right deriving from *any* international agreement, the provisions under the international agreement must be directly applicable and they must allow the holder of a PGI to take direct legal action to prohibit the use of a subsequent trade mark.

In the latter respect, international agreements are **not always self-executing**. This depends on the characteristics of the agreement itself and on how they have been interpreted in the relevant jurisdiction. For example, the Office considers that the provisions of the Lisbon Agreement (in particular Articles 3 and 8) are not self-executing. As expressly indicated by Article 8 of the Lisbon Agreement, it is the relevant national legislation that must determine which type of legal actions may be taken, their scope and whether these legal actions include allowing the proprietor of an appellation of origin to prohibit the use of a subsequent trade mark. Therefore, in such cases, the requisite national legislation must be adduced as this is a necessary component in order for the opponent to prove that the PGI in question can prevent use of the subsequent mark and that the opponent is entitled by the law governing the right to exercise this right.

International agreements entered into by the EU

PGIs deriving from agreements between the EU and third countries can be invoked under Article 8(4) CTMR if the provisions of these agreements vest the PGI in a **particular beneficiary or a precise class of users** that have direct right of action¹¹.

International agreements entered into by Member States including the Lisbon Agreement¹²

For the reasons set out in paragraph 3.2.4.2 above, a PGI protected under an international agreement concluded by Member States (either among Member States or with third countries) cannot be invoked as an earlier right under Article 8(4) CTMR if it encroaches upon the exhaustive nature of EU law in the relevant areas (currently foodstuffs, wines and spirits).

¹⁰ e.g. *grain spirit, wine spirit, fruit spirit, brandy, liqueurs, rum, whisky, gin*.

¹¹ PGIs from third countries can also be registered at EU level under the Foodstuffs, Wines and Spirits Regulations.

¹² Some Member States (Bulgaria, Czech Republic, France, Hungary, Italy, Portugal and Slovakia) are party to the Lisbon Agreement for the Protection of Appellations of Origin and their International Registration of 1958 (as revised at Stockholm 1967, and as amended on 28/09/1979). The European Union is **not** a signatory to the Lisbon Agreement.

In C-478/07 'BUD', the Court discussed the exhaustive nature of EU law as regards PGIs originating from Member States. In the Office's interpretation, this also applies a fortiori to third-country PGIs in the relevant product fields which enjoy protection in the territory of a Member State through an international agreement concluded between that Member State and a non-EU-country¹³.

This equally applies to the Lisbon Agreement. The Lisbon Agreement creates an international registration and protection system for 'appellations of origin' (Article 2(1)). The definition of 'appellations of origin' for food and beverage products under this agreement is largely equivalent to that of a 'designation of origin'¹⁴ under EU regulations. Therefore, appellations of origin protected in a Member State by virtue of the Lisbon Agreement cannot be a basis for opposition under Article 8(4) CTMR.

The only exceptions in this regard are the following.

- International agreements which cover PGIs which do not relate to foodstuffs, wines or spirits.
- International agreements concluded with third countries by a Member State before its accession to the EU. This is because the obligations arising out of an international agreement entered into by a Member State before its accession to the EU have to be respected. However, Member States are required to take all appropriate steps to eliminate the incompatibilities between an agreement concluded before a Member State's accession and the Treaty (see Article 307 Treaty Establishing the European Community, now Article 351 TFEU, as interpreted by the Court in its judgment of 18/11/2003, C-216/01 'BUD', paras. 168-172).
- International agreements concluded with a third country by a Member State after its accession to the EU, but before the entry into force of the uniform EU system of protection in the given product area.

As Member States are under obligation to eliminate incompatibilities with EU law, the Office will apply the last two exceptions (which exclusively concern third country PGIs in the fields of foodstuffs, wines or spirits) **only when the opponent expressly refers to the exception and supports it by a coherent line of argument and relevant evidence** (in particular, concerning the date of entry into force of the cited international agreement in the EU Member State where protection is claimed and its continued validity). General allegations by the opponent (such as merely citing the relevant international agreement) will not be sufficient in themselves for the Office to consider that one of the latter two exceptions applies.

3.2.4.4. Scope of protection of PGIs

The ability of PGIs to prevent use is governed by the relevant provisions of the EU Regulations (Articles 13, 103(2) and 16 of the Foodstuffs, Wines and Spirits Regulations respectively). In this context, **it is important to distinguish the latter**

¹³ To which the EU is not a contracting party.

¹⁴ This term is defined and explained in The Guidelines, Part B: Examination, Section 4 Absolute Grounds for Refusal and Community Collective Trade Marks, paragraph 2.09 on Article 7(1)(j) CTMR and paragraph 2.10 on Article 7(1)(k) CTMR.

provisions preventing use from those that prevent registration¹⁵ of a trade mark and which are not a basis for opposition under Article 8(4) CTMR¹⁶. Therefore, under Article 8(4) CTMR, a PGI can prevail if the conditions set out in the provisions preventing use are met, these are:

- the contested CTMA exclusively consists of the whole PGI or adds other words or figurative elements (direct or indirect use) for comparable products or, even for non-comparable products, if the use of the PGI exploits the reputation of the protected name¹⁷
- the contested CTMA contains or consists of an imitation or of an evocation of the PGI¹⁸
- other misleading indications and practices.¹⁹

Detailed information on the scope of protection of PGIs protected under the EU legislation is included in the Guidelines, Part B: Examination, Section 4 Absolute Grounds for Refusal and Community Collective Trade Marks, paragraph 2.09 on Article 7(1)(j) CTMR and paragraph 2.10 on Article 7(1)(k) CTMR (e.g. definitions of direct use, comparable products or evocation).

The provisions of the EU Regulations preventing use contemplate situations where a PGI can be invoked against goods or services which do not necessarily fall within the scope of objectionable goods and services under the *ex officio* examination of absolute grounds, subject to the conditions of the relevant provisions of the corresponding EU regulations. For instance, under Article 13(1)(a), Article 103(2)(a)(ii) and Article 16(a) of the Foodstuffs, Wines and Spirits Regulations respectively, a PGI with repute can be invoked against products and services which would not be *ex officio* objectionable under absolute grounds.

The scope of protection of PGIs that are protected by regulations other than the abovementioned EU Regulations depends on the relevant provisions.

Nevertheless, either under EU or national legislation, the scope of protection of PGIs cannot exceed what is required in order to safeguard the function of the PGI, the function in question is to designate goods as being from a particular *geographic origin and the special qualities connected therewith*. Unlike other signs, PGIs are not used to indicate the commercial origin of goods and they afford no protection in this regard. Therefore, where the specification of a CTMA **is limited to goods in conformity with the specification of the relevant protected PGI**, the function of the PGI in question is safeguarded in relation to those products because the CTMA only covers products from the particular *geographic origin and the special qualities connected therewith*. Consequently, an opposition against a CTMA which has been appropriately limited will not succeed. See in this regard Article 12(1) of the Foodstuffs Regulation or Article 103(1) of the Wines Regulation.

Where a PGI is invoked under Article 8(4) CTMR, as for all other signs under this article, the opponent **must prove that the sign is used in the course of trade of more than mere local significance**. The use must be made in accordance with the

¹⁵ Articles 14, 102 and 23 of the Foodstuffs, Wines and Spirits Regulations respectively.

¹⁶ See, in this sense, judgment of 12/06/2007, joined cases T-60/04 to 64/04, 'Bud', para. 78.

¹⁷ Article 13(1)(a), 103(2)(a), 16(1)(a) of the Foodstuffs, Wines and Spirits Regulations respectively.

¹⁸ Article 13(1)(b), 103(2)(b), 16(1)(b) of the Foodstuffs, Wines and Spirits Regulations respectively.

¹⁹ Article 13(1)(c) and (d), 103(2)(c) and (d), 16(1)(c) and (d) of the Foodstuffs, Wines and Spirits Regulations respectively.

essential function of such a sign, namely **to guarantee to consumers the geographical origin of the goods and the special qualities inherent in them**, but it must also be shown that the sign was used in the course of trade, that is, **as a distinctive element which serves to identify an economic activity engaged in by its proprietor** (see judgment of 29/03/2011, C-96/09P 'BUD', paras. 147 and 149, respectively). Therefore, documents mentioning a PGI exclusively in a non-trade context are not sufficient for the purposes of Article 8(4) CTMR.

3.3 Use requirements

In order to successfully invoke Article 8(4) CTMR in opposition proceedings, the earlier rights must be used. There are two different use requirement standards which must be taken into account:

- National standard
- European standard

The two use requirement standards, however, clearly overlap. They must not be viewed in isolation but have to be assessed together. This applies, in particular, to the 'intensity of use' under the National standard and 'use in trade of more than mere local significance' under the European standard.

3.3.1 National Standard

National standard is relevant as it defines the scope of protection of the earlier rights which are often not easily identifiable, all the more so since their protection is not harmonised on an EU level (see further below paragraph 3.4 on the scope of protection). This standard determines the existence of the national right and the conditions of protection. For non-registered trade marks and business identifiers which do not require registration, use constitutes the only factual premise justifying the existence of the right, including the ascertainment of the beginning of its existence. The National standard also prescribes the intensity of use under the relevant national law which may vary from mere first use in trade to use requiring recognition or reputation.

For example, right to an unregistered trade mark in Denmark is acquired by mere commencement of use of the mark in Danish territory.

In Germany, however, the right to an unregistered trade mark is acquired through use that has led to recognition by the relevant public of it as a trade mark ('Verkehrsgeltung'). According to case-law distinctive signs require 20 to 25% recognition whereas non-distinctive signs must acquire recognition by 50% of the relevant public.

3.3.2 European Standard – use in the course of trade of more than mere local significance

Under Article 8(4) CTMR, the existence of an earlier non-registered trade mark or of another sign gives good grounds for opposition if the sign satisfies, inter alia, the following conditions: it must be **used in the course of trade and** the use must be of **more than mere local significance**.

The above two conditions are apparent from the very wording of Article 8(4) CTMR and must, therefore, be interpreted in the light of Community law. The common purpose of the two conditions laid down in Article 8(4) CTMR is to limit conflicts between signs by preventing an earlier right which is not sufficiently definite – that is to say, important and significant in the course of trade – from preventing registration of a new Community trade mark. A right of opposition of that kind must be reserved to signs which actually have a **real presence** on their relevant market (judgment of 29/03/2011, C-96/09 P, ‘BUD’, para. 157).

3.3.2.1 Use in the course of trade

The first requirement under Article 8(4) CTMR is that the sign must be used in the course of trade.

The notion of ‘**use in the course of trade**’ in accordance with Article 8(4) CTMR is not the same as ‘**genuine use**’ in accordance with Article 42(2) and (3) CTMR (judgment of 30/09/2010, T-534/08, ‘Granuflex’, paras 24-27). The aims and conditions connected with proof of genuine use of registered Community or national trade marks are different from those relating to proof of use in the course of trade of the signs referred to in Article 8(4) CTMR (judgment of 09/07/2010, T-430/08 ‘Grain Millers’, para. 26, and judgment of 29/03/2011, C-96/09 P, ‘BUD’ para. 143). Therefore, use must be interpreted according to the particular type of right at issue.

The Court of Justice ruled that the ‘use of the sign in the course of trade’ within the meaning of Article 8(4) CTMR refers to the use of the sign ‘in the course of a commercial activity with a view to economic advantage and not as a private matter’ (judgments of 12/11/2002, C-206/01, ‘Arsenal Football Club’, para. 40; of 25/01/2007, C-48/05, ‘Adam Opel’, para. 18; of 11/09/2007, C-17/06, ‘Céline’, para. 17).

However, the Court of Justice also ruled that deliveries made without charge may be taken into account in order to ascertain whether the requirement for use of the earlier right in the course of trade has been met, since those deliveries could have been made in the context of a commercial activity with a view to economic advantage, namely to acquire new outlets (judgment of 29/03/2011, C-96/09 P ‘BUD’, para. 152).

As far as the **time of use** of the sign is concerned, an opponent must prove that use took place before the filing of the CTM application or the priority date if relevant (see judgment of 29/03/2011, C 96/09 P ‘BUD’, para. 166-168).

Earlier sign	Case No
BUD	C-96/09 P
<p>The Court discussed whether use which takes place exclusively or to a large extent between the filing of an application for registration and its publication was sufficient to meet the use requirement. One of the parties had argued that only the <i>acquisition</i> of the right had to take place before filing of the CTMA but not its <i>use</i>. The Court applied the same temporal condition as to the acquisition of the right and concluded that use had to take place before the filing of the application. The Court of Justice considered that in view of the considerable period of time which may elapse between the filing of an application for registration and its publication, the obligation of use in the course of trade of the sign before the filing of the application guarantees that the use claimed for the sign concerned is real and not an exercise whose sole aim has been to prevent registration of a new trade mark (paras 166 to 168).</p>	

In the case of unregistered signs, the use must be continuous and uninterrupted until the filing of the opposition, since otherwise there is no certainty that the rights in the unregistered sign have not lapsed. In this context, Rule 19(2)(d) CTMIR expressly states that if an opposition is based on an earlier right within the meaning of Article 8(4) CTMR, the opponent shall provide evidence of its acquisition, **continued existence** (emphasis added) and scope of protection of that right.

The following is an example of an *inter partes* case relating to invalidity proceedings. The reasoning and the findings also apply to oppositions, given that Article 8(4) CTMR is a ground that can be invoked both in opposition and in invalidity:

Earlier sign	Case No
<p style="text-align: center;">‘BAMBOLINA’ (non-registered mark in a number of MS)</p>	<p style="text-align: center;">Cancellation decision 3728 C (confirmed by BoA R 1822/2010-2, and judgment T-581/11)</p>
<p>The evidence showed use in the course of trade of the non-registered trade mark for three years, not covering the last two years before the date of filing of the invalidity request. The Cancellation Division held that an earlier non-registered sign relied on in an invalidity action must be in use at the time of filing the request. Since for these signs use constitutes the factual premise justifying the existence of the right, the same factual premise must still exist, and be proven, on the date of filing of the invalidity request (paras 25-28 of the Cancellation decision). The Board confirmed the finding of the Cancellation Division, adding that Rules 19(1) and (2)(d) CTMIR state that where an opposition is based on Article 8(4) CTMR, evidence of, <i>inter alia</i>, its ‘continued existence’ must be adduced within the period given by the Office for presenting or completing facts, evidence or arguments in support of the opposition. Failure to prove the existence, validity and scope of protection of the earlier mark or right within that period will lead to the opposition being rejected as unfounded (Rule 20(1) CTMIR). In the Board’s opinion, these Rules apply <i>mutatis mutandis</i> to cancellation proceedings (para. 15 of the BoA decision).</p>	

The requirement that the sign be used in the course of trade must, as stated above, be interpreted in the light of Community law. It must be distinguished from the requirements provided for under the applicable national laws which might set specific requirements as far as the **intensity of the use** is concerned.

The European use requirement as prescribed by Article 8(4) CTMR applies independently of whether national law allows prohibition of a subsequent trade mark on the basis of the registration of a sign alone, i.e. without any requirement relating to use. The following is an example where the opponent relied on the registration, at national level, of a trade name, but failed to prove that the sign was used in trade:

Earlier sign	Case No
<p style="text-align: center;">‘NACIONAL’ (Portuguese name of establishment)</p>	<p style="text-align: center;">R 693/2011-2</p>
<p>Under Article 8(4) CTMR, the fact that the opponent may, in accordance with the law of Portugal, have acquired exclusive rights plainly enforceable against subsequent trade marks on the basis of the registration of a ‘name of establishment’, does not exempt it from the burden of proving that the sign in question has been used in the course of trade of more than local significance. The mere fact that the sign is registered in accordance with the requirements of the respective Portuguese law is not in itself sufficient for the application of Article 8(4) CTMR (paras 20-26).</p>	

Depending on the applicable national law, an opponent might have to prove not only that the sign relied on is used in the course of trade (this being, as stated, a requirement under Community law), but also that it has been registered with the competent national authorities. It would not be sufficient that the European requirement of 'use in trade' is met if the registration requirement is not fulfilled. However, under certain national laws, rights in a company name may be invoked, as long as the company name has been used, prior to the registration of the entity in the companies register. The following is an example where the opponent invoked prior rights in a company name used in the course of trade in Germany that was not registered at the time of filing the contested CTMA:

Earlier sign	Case No
'Grain Millers GmbH & Co. KG' (German company name)	T-430/08
<p>The opponent invoked under Article 8(4) CTMR the company name 'Grain Millers GmbH & Co. KG' used in the course of trade in Germany for 'flour, in particular wheat flour and rye flour'. Therefore, the opponent claimed the name of a GmbH (Gesellschaft mit beschränkter Haftung, 'limited liability company' in English). The applicant argued that, according to Article 11(1) German Limited Companies Act (GmbH Gesetz), a GmbH does not exist before its registration and that the opponent was therefore not entitled, in support of its opposition, to rely on its business name, because the company was registered only after the filing of the contested CTM application. The GC took a different view and held that, according to the case-law of the German courts, the right to a business name exists pursuant to Paragraph 5(2) of the Markengesetz from the first use in the course of trade, without the obligation to register (para. 36).</p>	

A sign is used in the course of trade where that use occurs in the context of **commercial activity with a view to economic advantage** and not as a private matter.

Therefore, the Office will reject an opposition in the absence of actual use of the invoked sign. The following are examples where the opponent failed to meet this basic requirement:

Earlier sign	Case No
Octopussy (film title)	R 526/2008-4
<p>The opponent merely submitted general information explaining the content of the film, its characters, gross figures, video offers on the internet and advertisements without any details as regards the relevant market. The information as regards turnover is also insufficient since it is too broad a general reference to the activities carried out by the opponent and does not specify either the type of activity or the territories concerned. For the same reason, the figures from a periodical, relating to the box office receipts generated by the film, have no bearing on the use of the sign in Germany. The remaining press articles furnished by the opponent concern subjects which cannot corroborate the use of the sign in the Member States indicated. The licence agreements for merchandising do not constitute any evidence with regard to the use of the sign as a film title. Lastly, the mere fact that the film was a worldwide success cannot substitute the obligation of the opponent to file concrete evidence with regard to the Member States in which it claims protection under Article 8(4) CTMR (para. 26).</p>	

Earlier sign	Case No
'lucky-pet.de' (German domain name)	R 275/2011-1
The opponent invoked under Article 8(4) CTMR the domain name 'lucky-pet.de' used in the course of trade in Germany for 'mats for animals; retail services with respect to pet supplies'. It has not been proven that the domain has been used with more than local significance for the claimed goods and services. The invoices provided and the catalogue only show the internet address www.lucky-pet.de. However, they do not prove that the website www.lucky-pet.de has been visited and, if so, to what extent. It has neither been stated nor proven by any document how many people visited the website and ordered products via email (para. 31).	

3.3.2.2 Significance of the use

Rights falling under Article 8(4) CTMR may only be invoked if their use is of more than mere local significance. This requirement applies for all the rights within the scope of Article 8(4) CTMR, that is, both to unregistered trade marks and to other business identifiers. The proprietors of rights the use of which is of mere local significance retain their exclusive rights under the applicable national law pursuant to Article 111 CTMR.

The question whether the use of a non-registered sign is of more than mere local significance will be answered by applying a uniform European standard (see judgment of 18/04/2013, T-506/11, 'Peek & Cloppenburg', paras 19, 47-48).

The General Court held that the significance of a sign used to identify specific business activities must be established in relation to the identifying function of that sign. That consideration means that account must be taken, firstly, of the **geographical dimension** of the sign's significance, that is to say of the territory in which it is used to identify its proprietor's economic activity, as is apparent from a textual interpretation of Article 8(4) CTMR. Account must be taken, secondly, of the **economic dimension** of the sign's significance, which is assessed in view of the length of time for which it has fulfilled its function in the course of trade and the degree to which it has been used, of the group of addressees among which the sign in question has become known as a distinctive element, namely consumers, competitors or even suppliers, or even of the exposure given to the sign, for example, through advertising or on the internet (judgment of 24/03/2009, T-318/06 to T-321/06, 'GENERAL OPTICA', paras 36-37 and judgment of 30/09/2010, T-534/08, 'GRANUflex', para. 19).

The Court of Justice clarified that the significance of a sign cannot be a function of the mere geographical extent of its protection, since, if that were the case, a sign whose protection is not merely local could, by virtue of that fact alone, prevent registration of a Community trade mark, even though the sign might be used only to a very limited extent in the course of trade. The sign must be used in a sufficiently significant manner in the course of trade and its geographical extent must not be merely local, which implies, where the territory in which that sign is protected may be regarded as other than local, that the sign must be used in a **substantial part of that territory** (judgment of 29/03/2011 C-96/09 P 'BUD', para. 158-159).

However, it is not possible to establish a priori, in an abstract manner, which part of a territory must be used to prove that the use of a sign is of more than mere local significance. Therefore, the assessment of the sign's significance must be made *in concreto*, according to the circumstances of each case.

Therefore, the criterion of '**more than mere local significance**' is more than just a **geographical examination**. The **economic impact** of the use of the sign must also be evaluated. Consideration must be given, and the evidence must relate, to these elements:

- a) the intensity of use (sales made under the sign)
- b) the length of use
- c) the spread of the goods (location of the customers)
- d) the advertising under the sign and the media used for that advertising, including the distribution of the advertising.

In the following examples, both the geographic and the economic dimension of use of the sign were found to meet the standards:

Earlier sign	Case No
GLADIATOR (non-registered trade mark in the Czech Republic)	R 1529/2010-1
The around 230 invoices are sufficient to conclude that the sign 'GLADIATOR' has been used in the course of trade for 'all terrain vehicles'. They are issued to the opponent's clients in Czech cities such as 'Praha', 'Kraslice', 'Dolní Lánov', 'Pelhrimov', 'Opava', 'Bozkov', 'Plzeň' and many other Czech cities which cover many different areas of the Czech Republic. Furthermore, the catalogues and the magazines '4X4 Style' from 2007 are written in Czech and it is very likely that they are distributed in different venues within the Czech Republic. The documents such as the list of distributors, catalogues and magazines support the findings that the sign has been used in the course of trade (paras 22-33).	

Earlier sign	Case No
'FORGE DE LAGUIOLE' (French company name)	R 181/2007-1 (appealed T-453/11)
The company name 'FORGE DE LAGUIOLE', which the invalidity applicant adopted in 1994, appears on all the documents supplied, in particular on the articles of association and on the extract from the company's certificate of registration, on the company's letterhead, on the 1998 price lists and on the correspondence and invoices, dated from 1998, sent to addressees throughout France. The very rapid expansion of the invalidity applicant's activities and its sales network, as well as its sales turnover, is proved by the documents filed. From the list of customers for 2001 it is clear that the applicant had gained a clientele covering the whole of the French territory. This finding is also confirmed by the invoices produced, made out to customers all over France as well as in other European countries. Finally, the fact is established that the company is mentioned in a number of articles both in the French press and in the European and international press (paras 52-68).	

Earlier sign	Case No
'PORTO' (Portuguese appellation of origin)	Opposition B 998 510 (confirmed by the BoA in R 1101/2009-2)
The evidence filed, and the amount and content of the legislation, regulation and registration certificates indicate that Port wine has been and is being used as an appellation of origin for wine. It is clear from the evidence in its totality that the significance of the appellation of origin is not merely local, but rather has an international impact, as reflected in its history and its use as a tool to attract tourists. The promotion of the appellation of origin has taken place, among others, through the establishments 'SOLAR DO VINHO DO PORTO' in Lisbon and Oporto, as well as through the 'PORT WINE ROUTE', in the Douro region. Taking this into consideration, the Office finds that the opponent has proved that it has used its appellations of origin in the course of trade and that the use is of more than mere local significance.	

Earlier sign	Case No
BRADBURY (non-registered trade mark in the UK)	R 66/2008-2
<p>As regards goodwill of the mark, the BoA held that <u>the evidence submitted by the opponent was sufficient to prove that the BRADBURY non-registered sign enjoyed goodwill</u>: 1) The invoice evidence shows sales of a range of goods to various entities in the UK and in other countries. 2) The amounts of those invoices vary from a little over GBP 100 to several thousand pounds sterling. This evidence proves sales of products bearing the earlier non-registered mark to various entities. 3) The declarations and market survey also demonstrate that the sign has enjoyed a degree of recognition among the relevant public for the right holder's goods. 4) The fact that the sign appears in a number of catalogues and advertisements and that after sales service centres are located in various major towns and cities throughout the UK demonstrates that the trade mark has been brought to the attention of a wide public in terms of geographic spread (paras 31-33).</p>	

Earlier sign	Case No
'GOLDEN ELEPHANT fig.' (non-registered trade mark in the UK)	T-303/08
<p>The party relying on the earlier non-registered trade mark had sold rice consistently under the sign since 1988, i.e. for a period of eight years prior to the date on which the applicant filed the application for the contested Community trade mark. The quantity of rice sold – between 42 and 84 tonnes per year from 1988 to 1996 – cannot be regarded as totally insignificant. The mere fact that the party's market share was very small in comparison with the total amount of rice imported into the United Kingdom is not sufficient to justify a finding that those rice sales were below the <i>de minimis</i> threshold. In that context, it should be observed that the courts in the United Kingdom are very unwilling to assume that a business can have customers but no goodwill. 'Even if it were to be assumed that that goodwill had to be regarded as low on account of the limited quantities of the sales, it cannot, on any view, be regarded as non-existent' (paras 112-116).</p>	

As far as the use of the sign is concerned, in general, neither the territory of a city alone, even a big one, is of more than mere local significance, and nor is a regional district or province. It will depend on the circumstances of the case (see examples below). The leading judgment in this respect is the one rendered by the General Court in the *General Optica* case, where use of the sign was confined to a specific locality and was, therefore, insufficient to meet the prescribed requirements:

Earlier sign	Case No
Generalóptica (Portuguese establishment name)	Joined Cases T-318/06 to T-321/06
<p>It is not apparent from the evidence provided by the opponent that the significance of the sign relied on in the present case is more than merely local within the meaning of Article 8(4) CTMR. As the Board of Appeal stated in paragraph 33 of the contested decisions, it is apparent from the documents submitted by the opponent that at the time when registration of the first two Community trade marks was applied for, the sign in question had been used for almost 10 years merely to designate a business establishment open to the public in the Portuguese town of Vila Nova de Famalicão, which has 120 000 inhabitants. In spite of its explanations at the hearing, the applicant did not provide any evidence of recognition of the sign by consumers or of its business relationships outside the abovementioned town. Likewise, the applicant has not shown that it had developed any advertising activity in order to ensure that its business establishment was promoted outside that town. It must therefore be held that the business establishment name Generalóptica is of mere local significance within the meaning of Article 8(4) CTMR (para. 44).</p>	

Earlier sign	Case No
FORTRESS FORTRESS INVESTMENTS FORTRESS INVESTMENT GROUP (non-registered trade marks in the UK)	R 354/2009-2 R 355/2009-2
<p>The fact that the invalidity applicant was involved in the acquisition, lease-back and management of nationwide property portfolios of major UK institutions and companies proves that the use was of more than mere local significance. The fact that use is limited to London is relevant in the sense that London is the seat of nearly all governmental institutions and bodies and home to the City of London, one of the leading financial centres of the world. The economic dimension of the sign's significance was important since by mid-2000 the invalidity applicant had already an equity capital under management in excess of US\$1 billion. Furthermore, the group of addressees among which the sign was known is significant since it included major players in the financial field and UK public institutions. The exposure given to the sign was also significant, cf. the national and specialised press coverage. Therefore, use in the course of trade was of more than mere local significance (paras 49-51).</p>	

The notion that the use in trade of the sign relied on must be proven in the territory of the Member State/s where protection is sought is not incompatible with use of the sign in connection with **cross-border commercial transactions**:

Earlier sign	Case No
GRAIN MILLERS (German business name)	T-430/08
<p>The use of a business name in the context of the importation of goods from another State (in this case, documents of the transaction concluded by opponent concerning the import of wheat from Romania to Germany) is indeed use in the context of a commercial activity with a view to economic advantage, since import-export constitutes a normal, everyday activity of an undertaking, necessarily involving at least two States (para. 41).</p>	

The following are examples where the opponent failed to prove that the **economic dimension** of the use of the signs concerned was sufficient to meet the prescribed legal requirements:

Earlier sign	Case No
BUD (appellation of origin)	T-225/06 RENV, T-255/06 RENV, T-257/06 RENV, T- 309/06 RENV
<p>Four very small invoices for only three cities, without any advertisements, did not meet the requirement for use in the course of trade of a sign of more than mere local significance (para. 56). The same conclusion applied to Austria since the GC found that use was limited to deliveries of 12-25 hectolitres per year, for a marginal turnover (around EUR 1 200), almost exclusively in Vienna (paras 59-61).</p>	

Earlier sign	Case No
BRIGHTON (non-registered mark in several MS)	R 408/2009-4
<p>The sales chart provided by the opponent shows that the sale activities in the Member States concerned were not consistent over time to the extent that for certain years no sales at all appear to have taken place and that for others the sales revenue was very low indeed. Therefore, the sales figures show that the opponent was not able to maintain an intensity of use of the signs over three consecutive years. It is unlikely in those cases that the public was able to memorise the mark as an indication of origin. The opponent did not submit any evidence relating to the advertising and promotion of the marks invested in the concerned Member States, or other material showing that the signs in question had established themselves in the marketplace to such an extent as to justify the acquisition of exclusive rights in non-registered trade marks (paras 12-21).</p>	

Earlier sign	Case No
 (Greek non-registered mark)	R 242/2010-1
<p>Although the documents confirm the geographical extent of the trade mark to Greece, the evidence regarding the extent of time of the alleged use is clearly insufficient. The last dated document is from 1997, i.e. seven years before the contested application was submitted. Moreover, the most recent documents in which the trade mark 'ESKIMO' can be seen are the invoices dating from 1991 to 1994. They only reflect the sales of a little less than 100 units throughout these four years, which cannot be deemed sufficient to prove the use of the mark as a business identifier by the opponent (paras 27-28).</p>	

Earlier sign	Case No
Up Way Systems – Representações Unipessoal LDA (Portuguese company name)	R 274/2012-5
<p>Three invoices, addressed to companies in the Porto region of Portugal, for a total sales amount of EUR 16 314, are not sufficient to show that the sign was used in the course, considering the price level of building materials and building services in general (paras 20-23).</p>	

Use of a sign relied on under Article 8(4) CTMR must be made in accordance with the essential **function** of such a sign. This means that if an opponent relies on a non-registered trade mark, proof of use of the sign as a company name would not be sufficient to substantiate the earlier right.

The following is an example where the evidence shows use of a sign whose function does not correspond to that of the sign relied on:

Earlier sign	Case No
JAMON DE HUELVA (Spanish trade name)	R 1714/2010-4
<p>The proof furnished in order to substantiate the use of 'Jamón de Huelva' almost exclusively relates to the designation of origin 'Jamón de Huelva'. Designations of origin are very different legal concepts from trade names, as, instead of identifying a particular commercial origin, they are geographical indications relating to an agricultural or food product of which the quality or characteristics are fundamentally or exclusively due to the geographical environment in which they are produced, processed or prepared. The opposition based on the use in Spain of the trade name 'Jamón de Huelva' must be dismissed in view of the fact that the proof furnished does not relate to this legal concept and does not identify a specific commercial activity, but instead the activities relating to a designation of origin and the Supervisory Council thereof (paras 34-37).</p>	

The requirement that the sign must be used in trade for its own particular economic function does not exclude that the same sign might be used for several purposes.

It is common market practice to also use company or trade names as trade marks, either alone, or together with other product identifiers. This is the case when use of a 'house mark' is concerned, that is, an indication which usually coincides with the manufacturer's company or trade name and which not only identifies the product or service as such, but also provides a direct link between one or more product/service lines and a specific undertaking.

Therefore, depending on the specific circumstances of the case, in a case where an opponent relies on a non-registered trade mark, the use of the same sign as a company name or trade name may well also accomplish the function of indicating the origin of the goods/services concerned (thus, a trade mark function), as long as the sign is used in such a way that a link is established between the sign which constitutes the company or trade name and the goods marketed or the services provided (see, by analogy, judgment of 11/09/2007, C-17/06 'CELINE' paras 22-23).

3.4 Earlier right

The right invoked under Article 8(4) CTMR must be earlier than the CTM application. In order to determine which of the conflicting rights is earlier, the relevant dates on which the rights were obtained must be compared.

- For the **CTM application**, this is the filing date or any priority date validly claimed (hereinafter the 'CTM date'). Seniority claims, even if they relate to the Member State where the other earlier right is claimed to exist, are not relevant.
- As regards the **right falling under Article 8(4) CTMR**, the relevant date of acquisition of exclusive rights under the national law is decisive (see judgment of 07/05/2013, T-579/10 'makro', where the Court confirmed the Board's rejection of evidence submitted by the invalidity applicant, which related to periods subsequent to the owner's application for the CTM (para. 70).

Where under the national law mere use is sufficient, this must have begun before the CTM date. Where recognition in the trade or reputation are required, these must have

been acquired before the CTM date. Where these conditions are fulfilled only after the CTM date, the opposition will have to be rejected.

3.5 Scope of protection

Earlier rights falling under Article 8(4) CTMR are protected only if they confer on their proprietors under the applicable law the right to prohibit the use of a later trade mark.

This requires a finding that under the applicable national law rights of the type involved, in the abstract, are exclusive rights enforceable by means of an injunction vis-à-vis later marks and a finding that in the actual case under consideration the conditions for obtaining such injunctive relief, if the mark that is the subject of the opposed CTM application were used in the territory in question, are present (scope of protection). Both questions have to be answered in accordance with the applicable law. The Office will apply the laws of the Member States, Community law or International agreements.

For many, if not most, of the rights falling under Article 8(4) CTMR, the prerequisites of national regulations are quite similar to those applied in conflicts between trade marks which Office examiners are familiar with, namely, likelihood of confusion, or damage to reputation or distinctiveness.

For example, unregistered marks are generally protected against subsequent marks in the event of a likelihood of confusion and, thus, in accordance with the same criteria that are applicable to conflicts between registered marks, namely, identity or similarity of the signs, identity or similarity of the goods or services, etc. In these cases, the criteria developed by the courts and by the Office for applying Article 8(1) CTMR may easily be transported into Article 8(4) CTMR, unless the party can provide relevant case-law of the national courts proving a different approach.

Where the applicable national law provides protection for unregistered trade marks, which is different from that found in Article 8(1) CTMR, the scope of protection of the earlier right invoked follows from national law. If, for example, the applicable national law grants protection to unregistered marks also for dissimilar goods and services under certain conditions, the same protection will be granted under Article 8(4) CTMR.

4 Proof of the Applicable Law Governing the Sign

4.1 The burden of proof

According to Article 76(1) CTMR, in all *inter partes* cases, the burden is on the party making a particular claim or allegation to provide the Office with the necessary facts and arguments in order to substantiate the claim. Unlike other grounds in Article 8 CTMR, Article 8(4) CTMR does not specify the conditions governing the acquisition and scope of protection of the earlier right invoked. It is a framework provision where the particulars of the applicable law must be provided by the opponent.

Rule 19(2)(d) CTMIR provides that if an opposition is based on an earlier right within the meaning of Article 8(4) CTMR, the opponent shall provide evidence of its acquisition, continued existence and scope of protection.

It follows from the law as interpreted by the Court that the opponent must provide the relevant national law and show that it would succeed under that national law in preventing the use of a subsequent trade mark:

In that regard, it should be observed that Article 8(4)(b) [CTMR] lays down the condition that, pursuant to the law of the Member State governing the sign relied on under Article 8(4), that sign confers on its proprietor the right to prohibit the use of a subsequent trade mark.

Furthermore, in accordance with Article 74(1) of Regulation 40/94 [now Article 76(1) CTMR], the burden of proving that that condition is met lies with the opponent before OHIM.

In that context and in relation to the earlier rights relied on ... regard must be had, in particular, to the national rules advanced in support of the opposition and to the judicial decisions delivered in the Member State concerned and that, on that basis, the opponent must establish that the sign concerned falls within the scope of the law of the Member State relied on and that it allows use of a subsequent mark to be prohibited.

(See judgment of 29/03/2011, C-96/09 P 'BUD', paras 188-190.)

The Court held that in applications for a declaration of invalidity brought under Article 53(2) CTMR, it is for the party who seeks to rely on an earlier right protected under national law

to provide OHIM not only with particulars showing that he satisfies the necessary conditions, in accordance with the national law of which he is seeking application, in order to be able to have the use of a Community trade mark prohibited by virtue of an earlier right, but also particulars establishing the content of that law.

(See judgments of 05/07/2011, C-263/09 P, 'Elio Fiorucci', para. 50 and 27/03/2014, C-530/12 P, 'Representation of a hand', para. 34.)

Although these judgments referred to invalidity proceedings under Article 53(2) CTMR, since Article 8(4) also concerns the application of earlier rights protected under European Union legislation or under the law of the Member State governing the sign at issue, the cited case-law also applies to oppositions brought under Article 8(4) CTMR.

The information on the applicable law must allow the Office to understand and apply the content of that law, the conditions for obtaining protection and the scope of this protection, and allow the applicant to exercise the right of defence. It may also be particularly useful to submit evidence of relevant case-law and/or jurisprudence interpreting the law invoked.

The Office must effectively assess the applicability of the ground for refusal invoked. In order to ensure the correct application of the law invoked, the Office has the power to verify, by whatever means it deems appropriate, the content, the conditions governing the application and the scope of the provisions of the applicable law relied upon by the opponent (see judgment of 27/03/2014, C-530/12 P, 'Representation of a hand', paras 44-46), while respecting the parties' right to be heard. If, after verifying the evidence submitted, the Office is of the opinion that the parties' proposed interpretation or application of the law invoked was inaccurate, it can introduce new and/or additional

elements. In order to respect the parties' rights to be heard, the Office will invite the parties to comment on these elements, where appropriate.

This power of verification is limited to ensuring the **accurate application of the law relied upon by the opponent**. It does not therefore discharge the opponent from the burden of proof and it cannot serve to substitute the opponent in adducing the appropriate law for the purposes of its case (see decision of 02/06/2014, R 1587/2013-4 'GROUP', para. 26 and decision of 30/06/2014, R 2256/2013-2 'ENERGY', para. 26).

4.2 Means of evidence and standard of proof

Pursuant to Article 8(4) CTMR, the applicable law may be the law of a Member State or European Union law.

4.2.1 National law

As regards national law, the opponent must provide:

a) **the provisions of the applicable law:**

- on the **conditions governing acquisition of rights** (whether there is a requirement of use and, if so, the standard of use required; whether there is a registration requirement, etc.); and
- on the **scope of protection of the right** (whether it confers the right of prohibition of use; the injury against which protection is provided, e.g. likelihood of confusion, misrepresentation, unfair advantage, evocation).

b) **particulars proving fulfilment of the conditions:**

- of **acquisition** (entitlement; earlier acquisition; whether it is in force; evidence of use if use-based; evidence of registration if registration-based, etc.); and
- of **the scope of protection** (facts, evidence and/or arguments that the requirements laid down by the applicable law for a prohibition of use are met, e.g. the nature of the goods, services or business activity protected by the earlier right and their relation with the contested goods or services; a cogent argument showing that there is a risk of injury).

First, as regards the provisions of the applicable law (see point a) above), the opponent must provide the reference to and content of the applicable law invoked. The opponent must provide the *reference* to the relevant legal provision (article number and the number and title of the law) and the *content* (text) of the legal provision either in its submission or by highlighting it in another publication attached to the submission (e.g. excerpts from an official journal, a legal commentary or a court decision). If the relevant provision refers to a further provision of law, this must also be provided to enable the applicant and the Office to understand the full meaning of the provision invoked and to determine the possible relevance of this further provision.

As the opponent is required to **prove** the content of the applicable law, **it must provide the applicable law in the original language**. If that language is not the language of the proceedings, the opponent must also provide a **complete translation** of the legal provisions invoked in accordance with the standard rules of substantiation. However, a mere translation of the applicable law does not itself constitute proof and cannot substitute the original; therefore, the translation alone is not considered sufficient to prove the law invoked. See Rule 19(2)(d) CTMIR, which requires evidence to be submitted and Rule 19(3) CTMIR, which requires translations be submitted within the time limit specified for submitting the original document.

Where the opponent seeks to rely on national case-law or jurisprudence interpreting the law invoked, it must provide the relevant information in sufficient detail (e.g. a copy of the decision invoked or excerpts from the legal literature) and not merely by reference to a publication. The translation rules apply equally to that evidence.

Second, as regards the particulars proving fulfilment of the conditions of the applicable law (see point b) above), apart from providing appropriate evidence of acquisition of the right invoked, the opponent must submit evidence that the conditions of protection vis-à-vis the contested mark are actually met and, in particular, put forward a cogent line of argument as to why it would succeed in preventing the use of the contested mark under the applicable law. Merely providing the applicable law itself is not considered sufficient, as it is not up to the Office to make the relevant argument on behalf of the opponent.

Furthermore, in an opposition under Article 8(4) CTMR, what matters is whether the relevant provisions of the law conferring on the opponent the right to prohibit the use of a subsequent trade mark would apply to the contested mark in the abstract, and not whether the use of the contested mark could actually be prevented. Therefore, the applicant's argument in defence that the opponent had not hitherto invoked or had not hitherto been able to prevent the actual use of the contested mark in the relevant territory cannot succeed (see judgment of 29/03/2011, C-96/09 P 'BUD', paras 191 and 193).

At the end of this Section of the Guidelines, there is an overview **Table** with the essentials of national laws applicable in the Member States. It is included in these Guidelines for information purposes only. As this table contains a description of the legal provisions for information purposes only, merely referring to the table does not discharge the opponent from the duty of proving the relevant law governing the sign that confers on it the right to prohibit the use of a later trade mark, as described above (see decision of 22/01/2013, R 1182/2011-4, 'Crown Lounge (fig. mark)', paras 48-50).

Based on the above, the Office will reject the opposition if:

- the opponent invokes a right but does not include a **reference** to any specific national law and/or legal provision protecting that right (e.g. the opponent only indicates that the opposition is based on a commercial designation in Germany or that the opposition based on a commercial designation in Germany is protected under DE-TMA); or
- the opponent provides a reference to the applicable national law and legal provision(s) but the reference is not complete: the legal provision only indicates the conditions governing the **acquisition** of the right but not the **scope of protection** of the right (or vice-versa) (e.g. the opponent indicates that the opposition is based on a commercial designation in Germany protected under Article 5 DE-TMA, which establishes the conditions for acquisition of the right, but

- the reference to the conditions governing the scope of protection, Article 15 DE-TMA, is missing); or
- the opponent provides the reference to the relevant legal provision but does not provide the **content** (text) of the legal provision (e.g. the opponent's submission refers to the DE-TMA but does not include the content of the law); or
 - the opponent provides the content of the legal provision only in the language of the proceedings but not in the **original language** (e.g. the language of the proceedings is English but the text of the DE-TMA is submitted only in English, not in German); or
 - the opponent does not provide any or sufficient evidence of the acquisition of the right invoked or does not provide arguments as to why it fulfils the conditions governing the scope of protection (e.g. the opponent refers to the relevant legal provisions and provides their content both in the original language and translated into the language of the proceedings, but does not provide any or sufficient evidence of the acquisition of protection or does not state whether it fulfils the conditions of the scope of protection).

4.2.2 European Union law

The above requirements also apply to European Union law, except that the opponent is not obliged to provide the content (text) of the law invoked. However, the opponent has to provide particulars proving the fulfilment of the conditions under the relevant provisions of European Union law (point b) above).

TABLE ON NATIONAL RIGHTS THAT CONSTITUTE 'EARLIER RIGHTS' IN THE SENSE OF ARTICLE 8(4) CTMR

FOR INFORMATION PURPOSES²⁰

Table of Contents

1	Benelux.....	34
2	Bulgaria	35
3	Czech Republic.....	36
4	Denmark	37
5	Germany.....	38
6	Estonia.....	40
7	Ireland.....	41
8	Greece	42
9	Spain.....	44
10	France.....	45
11	Croatia	46
12	Italy	47
13	Cyprus	48
14	Latvia	49
15	Lithuania.....	50
16	Hungary	50
17	Malta	51
18	Austria	51
19	Poland.....	53
20	Portugal	54
21	Romania	56
22	Slovenia.....	57
23	Slovakia	57
24	Finland.....	58
25	Sweden.....	60
26	United Kingdom.....	61

²⁰ The content of the Table is largely based on information and feedback from trade mark offices and user associations in 2013/2014. However, it is not a legal source and is made available for information purposes only. It may not contain the latest legislative developments or an exhaustive list of all national rights that can be invoked under Article 8(4) CTMR.

1 Benelux

1.1 Unregistered trade marks

Unregistered trade marks (TMs) are not recognised under the uniform Benelux Convention on Intellectual Property (BCIP).

1.2 Other signs used in the course of trade

For the Benelux territory each state must be considered separately.

1.2.1 Belgium

Trade name (nom commercial)/Company name (dénomination sociale)

Article 2.19 BCIP

Article 95 of 'Loi du 6 avril 2010 relative aux pratiques du marché et à la protection du consommateur'

Article 1382 of the 'Code Civil' (Civil Code)

Conditions for protection

Trade name is acquired by its first use in trade. Protection is limited to the geographical area where the trade name or company name is used.

Company name is acquired, in principle, from the date of the establishment of the company. Protection extends to the whole national territory.

Rights conferred

Right to prohibit use of subsequent (registered) trade marks.

1.2.2 Luxembourg

Trade name (nom commercial)/company name (dénomination sociale)

Article 2.19 BCIP

Article 14 of 'Loi du 30 juillet 2002 réglementant certaines pratiques commerciales, sanctionnant la concurrence déloyale et transposant la directive 97/55/CE du Parlement Européen et du Conseil modifiant la directive 84/450/CEE sur la publicité trompeuse afin d'y inclure la publicité comparative'

Rights conferred

Right to prohibit use of subsequent (registered) trade marks.

1.2.3 Netherlands

Trade name

Article 2.19 BCIP

Law of 5 July 1921 on trade names (Handelsnaamwet)

Article 6:162, Dutch Civil Code (Burgerlijk Wetboek)

Conditions for protection

Right is acquired by the first use of the trade name in trade. Protection is limited to the geographical area where the trade name is used. Trade names may be registered voluntarily with the Trade Register at the Chamber of Commerce but doing so does not confer any rights on the owner. There is no particular requirement that the trade name be distinctive and non-descriptive.

Rights conferred (a) and conditions (b)

- (a) Right to prohibit use of subsequent (registered) trade marks.
- (b) Likelihood of confusion must be found.

2 Bulgaria

2.1 Unregistered trade marks

Unregistered trade marks (TMs) are protected in Bulgaria in two ways.

Unregistered TMs

Article 12(6) Bulgarian Trade Mark Law on Marks and Geographical Indications (2010)

Conditions for protection

The TM must have been used in the course of trade in the territory of Bulgaria prior to the filing date of the contested trade mark.

Rights conferred (a) and conditions (b)

- (a) Right to prohibit registration of a subsequent trade mark.
- (b) The subsequent trade mark must be identical or similar and must cover identical or similar goods and/or services.

Well-known TMs

Article 12(2)7 Bulgarian Trade Mark Law on Marks and Geographical Indications (2010)

Conditions for protection

The TM must be well-known in the territory of Bulgaria within the meaning of Article 6bis of the Paris Convention prior to the filing date of the contested trade mark.

Rights conferred (a) and conditions (b)

- (a) Right to prohibit registration of a subsequent trade mark.
- (b) The subsequent trade mark must be identical or similar and must cover identical or similar goods and/or services.

2.2 Other signs used in the course of trade

Other signs used in the course of trade are not included by Bulgarian trade mark law as prior rights that could form a basis for opposition.

3 Czech Republic

3.1 Unregistered trade marks

Unregistered trade marks are protected in the Czech Republic:

Article 7(1)(g) of the Czech Trade Marks Act (CZ-TMA).

Conditions for protection

Unregistered signs that have acquired distinctiveness through use in the course of trade of more than mere local significance prior to the filing of the contested application.

Rights conferred (a) and conditions (b)

- (a) Right to prohibit subsequent trade marks.
- (b) Signs must be identical or similar (interpreted as likelihood of confusion) and must cover identical or similar goods and/or services. Scope of protection is identical to that of a Czech registered mark.

3.2 Other signs used in the course of trade

Article 7(1)(g) CZ-TML

Trade names and other related signs (e.g. names of non-commercial organisations)

Conditions for protection

These names/signs must have acquired distinctiveness through use in the course of trade of more than mere local significance prior to the filing of the contested application.

Rights conferred (a) and conditions (b)

- (a) Right to prohibit subsequent trade marks.
- (b) Signs must be identical or similar (interpreted as likelihood of confusion) and must cover identical or similar goods and/or services. Scope of protection is identical to that of a Czech registered mark.

4 Denmark

4.1 Unregistered trade marks

Unregistered trade marks (TMs) are protected in Denmark:

§ 3(1)(ii) of the Danish Trade Mark Act (DK-TML)

§ 4(1), (2) and § 15(4)(ii) DK-TML

Conditions for protection

Rights to an unregistered TM are acquired by starting to use the TM in Denmark.

Rights conferred (a) and conditions (b)

- (a) Right to prohibit use of subsequent (registered) TMs.
- (b) The unregistered TM must continue to be used for the goods and/or services for which it was first used. The scope of protection is the same as for Danish registered TMs, i.e. corresponding to Article 9(1)(a), (b) and (c) CTMR.

4.2 Other signs used in the course of trade

Company names

The term 'company name' is to be interpreted broadly and covers not only private companies such as private firms, limited liability companies, other commercial companies and secondary trade names but also foundations, unions, associations, museums and public institutions.

§ 18 Danish Marketing Practices Act

§ 2(ii) Danish Companies Act

§ 6(ii) Consolidated Act on Certain Commercial Undertakings

Conditions for protection

Company name protection does not require registration. However, the person concerned must have legal title to the company name.

Rights conferred (a) and conditions (b)

(a) Right to prohibit use of subsequent (registered) trade marks.

(b) Signs must be identical or similar.

Signs used in the course of trade such as business names and shop facades

The term 'signs used in the course of trade' is to be interpreted broadly and, according to Danish law, covers any commercial name or symbol that can serve as a connecting link between a business and its customers/users, including, inter alia, business names and shop facades.

§ 18 Danish Marketing Practices Act

5 Germany

5.1 Unregistered trade marks

§ 4 No 2 German Trade Mark Act (DE-TMA), § 12, 14 DE-TMA

Conditions for protection

Protection is acquired through use leading to recognition by the relevant public as a trade mark ('Verkehrsgeltung') (§4 No 2 DE-TMA). According to case-law, 20 to 25% recognition by the relevant public is normally sufficient, rising to 50% or more if a sign is not distinctive.

Rights conferred (a) and conditions (b)

- (a) Right to prohibit the use of a subsequent trade mark if recognition is established in the whole of Germany, i.e. not if recognition is only established for a particular town or region (§§ 12, 14 DE-TMA).
- (b) The same as for registered German trade marks, i.e. protection corresponds to Article 9(1)(a), (b) and (c) CTMR (§ 14(2) No 1, 2 and 3 DE-TMA).

5.2 Other signs used in the course of trade

§5(1), (2), (3) DE-TMA

Commercial designations ('geschäftliche Bezeichnungen') is a broad category that includes the following.

Company symbols ('Unternehmenskennzeichen') are signs used in the course of trade as a name, company name or special designation of a business operation or enterprise. Business symbols and other signs that are intended to distinguish one business operation from others and are regarded as symbols of the business operation by the relevant public are deemed equivalent to the special designation of a business operation.

A **name or firm** is a trader's official or officially registered designation. A business symbol is a sign used by a trader to identify its business or undertaking as such, which functions as the name of the business or enterprise.

Titles of works are the names or special designations of printed publications, cinematic works, music works, stage works or other comparable works. This can be an individual work, a series of works, or a periodical publication. This also includes titles of radio or television series, computer games and video games, possibly also computer programs. It is not required that the work designated by the title is protected under copyright law.

Conditions for protection

Company symbols – If the sign is inherently distinctive, protection is acquired through use in the course of trade as a company symbol. According to case-law the required degree of inherent distinctiveness is low. 'Use in the course of trade as a company symbol' covers every external business activity in Germany aimed at long-term commercial activity. If the sign is not inherently distinctive, protection is acquired through recognition as a sign of the undertaking by the relevant public ('Verkehrsgeltung').

Business symbols and other signs for distinguishing business operations – Protection is acquired through recognition as a sign of the undertaking by the relevant public.

Titles of works: if the title of work is inherently distinctive, acquisition through use in the course of trade, i.e. normally as from the appearance of the work. The required degree of inherent distinctiveness is low. If the work title is not inherently distinctive, acquisition of the right through market recognition ("Verkehrsgeltung").

Rights conferred (a) and conditions (b)

- (a) Right to prohibit use of a subsequent trade mark.
- (b) Likelihood of confusion (§ 15(2) DE-TMA); in the case of a business designation with reputation, if use would take unfair advantage of, or would be detrimental to, the distinctive character or repute of a commercial designation (§ 15(3) DE-TMA).

6 Estonia

6.1 Unregistered trade marks

Unregistered trade marks are not protected under Estonian law unless the marks are considered to be well-known in Estonia within the meaning of Article 6^{bis} of the Paris Convention.

6.2 Other signs used in the course of trade

Business names

Article 10(1)(4) of the Estonian Trade Mark Act (EST-TMA)

Conditions for protection

Entry in the commercial register prior to the filing date of the application, the date of international registration or the priority date. Protection for a business name is acquired from the date of entry in the commercial register.

Rights conferred (a) and conditions (b)

- (a) Right to prohibit use of subsequent (registered) trade marks.
- (b) Signs must be identical or similar and the area of activity for which a notation has been made in the commercial register must include the goods and/or services for which the contested trade mark is used or is going to be used (designates).

Names of proprietary medicinal products

Article 10(1)(5) EST-TMA

Conditions for protection

The names must be registered in Estonia prior to the filing date of the trade mark application, the date of international registration or the date of priority.

Rights conferred (a) and conditions (b)

- (a) Right to prohibit use of subsequent (registered) trade marks.
- (b) The contested sign must be identical or confusingly similar to the name of a proprietary medicinal product registered in Estonia and the goods for which the trade mark is used or is going to be used must belong to the field of medicine.

7 Ireland

7.1 Unregistered trade marks

Unregistered trade marks (TMs) used in the course of trade are protected in Ireland.

Section 10(4)(a) IE-TMA

Conditions for protection

Must be used in the course of trade if protected by any rule of law, including that of passing off.

Rights conferred (a) and conditions (b)

- (a) Right to prohibit the use of subsequent trade mark if protected by any rule of law, in particular the law of passing off.
- (b) The later sign must constitute a misrepresentation likely to lead to deception or confusion, with consequent likelihood of damage to the goodwill or business of the proprietor of the earlier sign. The plaintiff must prove that its goodwill and business suffered or are likely to suffer damage as a result of the defendant's activities.

The action for passing off is based upon goodwill acquired by use of the earlier sign. Goodwill is sometimes referred to as reputation. In Ireland, goodwill can be acquired without necessarily trading within the territory, provided that a reputation in Ireland or customers in Ireland can be proven. The tort arises if a later sign constitutes a misrepresentation likely to lead to deception or confusion, with consequent likelihood of damage to the goodwill or business of the proprietor of the earlier sign. The law is explained in 'Intellectual Property Law in Ireland' by Robert Clark, Shane Smyth, Niamh Hall, Bloomsbury Professional, 3rd edition 2010 (see <http://www.bloomsburyprofessional.com/1155/Bloomsbury-Professional-Intellectual-Property-Law-in-Ireland-3rd-edition.html>). Authoritative statements of the law are found in court judgments, for example in *C. & A. Modes vs C. & A. (Waterford)* [1978] Fleet Street Reports 126; *Adidas K.G. v. O'Neill & Co Limited* [1983] Fleet Street Reports 76; *Guinness Ireland Group v. Kilkenny Brewing Co Limited* [2000] Fleet Street Reports 112; *Allergan Inc. v Ocean Healthcare Ltd* [2008] IEHC 189; *Jacob Fruitfield Food Group Ltd v United Biscuits (UK) Ltd* [2007] IEHC 368; and *McCambridge v Brennan Bakeries Ltd* [2012] IESC 46.

7.2 Other signs used in the course of trade

Business sign used in the course of trade

Section 10(4)(a) and (5), IE-TMA

Right to prohibit use of subsequent TMs if protected by any rule of law, in particular the law of passing off. On the law of passing off, see remarks above under point A.

Conditions for protection

As under Section 7.1 above.

a) Rights conferred (a) and conditions (b)

As under Section 7.1 above.

8 Greece

8.1 Unregistered trade marks

There are two sets of provisions dealing with the protection of unregistered trade marks and related signs: (a) trade mark law confers on the owner the right to prohibit registration of a later trade mark, whereas (b) the law on unfair competition and other specific provisions deal with the issue of use. As the complementary application of trade mark law for any matter not directly dealt with in other statutes is generally accepted, both sets of rules are indicated.

Article 124(3)(a) GR-TML (Law No 4072/2012); Article 13(1) of Law 146/1914 on Unfair Competition

Conditions for protection

Protection is acquired through use in the course of trade. If not inherently distinctive, unregistered trade marks must also be 'established in the market'.

Rights conferred (a) and conditions (b)

- (a) Right to prohibit registration of a subsequent trade mark.
- (b) Prior use, likelihood of confusion as to origin.

8.2 Other signs used in the course of trade

Company names

Article 58 Civil code

Articles 4-8 Law 1089/1980, as amended by 1746/1988

Conditions for protection

Protection is acquired exclusively through use in the course of trade. Registration is not relevant for protection; it only serves administrative purposes.

Rights conferred (a) and conditions (b)

- (a) Right to prohibit subsequent trade marks.
- (b) Prior use, likelihood of confusion as to origin.

Trade names and commercial establishment insignia

Article 124(3)(a) GR-TML (Law No 4072/2012)

Article 13(1)(2) Law 146/1914 on Unfair Competition

Conditions for protection

Protection is acquired exclusively through use in the course of trade. If not inherently distinctive, the trade name or insignia must also be 'established in the market'.

Rights conferred (a) and conditions (b)

- (a) Right to prohibit subsequent trade marks.
- (b) Prior use, likelihood of confusion as to origin.

Other distinctive signs

Article 124(3)(a) GR-TML

The peculiar shape of the goods or of their packaging, as well as the peculiar get-up or decoration thereof (Ιδιαίτερος διασχηματισμός, διακόσμηση).

Conditions for protection

The signs must be known in the relevant commercial sector as product identifiers of a given trader. Protection is acquired through use in the course of trade. The signs must be capable of performing a trade mark-like function (i.e. they must have distinctive character as a result of a certain degree of originality).

Rights conferred (a) and conditions (b)

- (a) Right to prohibit subsequent trade marks.
- (b) Prior use, likelihood of confusion as to origin.

General note: All the exclusive signs referred to above are also protected under **Article 1 of Law 146/1914 on 'Unfair Competition'**, especially as regards infringing acts not covered by the above provisions (e.g. **protection of reputed signs for dissimilar goods** – dilution of, or unfair advantage to, their distinctiveness or repute, that is, where likelihood of confusion is not relevant).

9 Spain

9.1 Unregistered trade marks

Unregistered trade marks are not protected in Spain unless they are considered to be well known in Spain within the meaning of Article 6^{bis} of the Paris Convention.

9.2 Other signs used in the course of trade

Business names (Nombres comerciales)

Article 7(1)(a) and (b), 7(2)(a) and (b) ES -TML

Conditions for protection

The name must be registered or applied for at the Spanish Patent and Trade Mark Office.

Rights conferred (a) and conditions (b)

- (a) Right to oppose and prohibit the use of subsequent trade marks.
- (b) Identical or similar signs and identical or similar goods or services and likelihood of confusion.

Business names, designations or corporate names of legal persons

Article 9(1)(d) ES–TML

Conditions for protection

The names do not have to be registered or applied for at the Spanish Patent and Trade Mark Office provided that they identify a person (enterprise) for the purposes of trade. Evidence of use or evidence that the sign is well known in the national territory must be provided.

Rights conferred (a) and conditions (b)

- (a) Right to prohibit the use of subsequent trade marks.
- (b) Identical or similar signs and identical or similar goods or services and likelihood of confusion.

10 France

10.1 Unregistered trade marks

Unregistered trade marks are not recognised under French law with the exception of well-known trade marks in the sense of Article 6bis of the Paris Convention (Article L711-4(a) French Intellectual Property Code (FR-IP CODE))

10.2 Other signs used in the course of trade

Article L711-4 FR-IP Code provides a non exhaustive list of signs that, if qualified as earlier, might prohibit use of a later trade mark.

Company name or style of a company ('dénomination sociale', "raison sociale")

Article L711-4(b) FR-IP Code

Conditions for protection

Protection of the company name is acquired upon completion of the documents founding the company. Must be known throughout the French territory.

Rights conferred (a) and conditions (b)

- (a) Right to prohibit use of a subsequent trade mark.
- (b) There must be a risk of confusion in the mind of the public.

Trade name (nom commercial)

Article L711-4(c) FR-IP CODE

Conditions for protection

Protection acquired from first use in trade.

Rights conferred (a) and conditions (b)

- (a) Right to prohibit use of a subsequent trade mark.
- (b) There must be a risk of confusion in the mind of the public.

Business sign ('enseigne')

Article L711-4(c) FR-IP CODE

Conditions for protection

Protection acquired from first use in trade. Must be known throughout the territory of France (enseigne notoire).

Rights conferred (a) and conditions (b)

- (a) Right to prohibit use of a subsequent trade mark.
- (b) There must be a risk of confusion in the mind of the public.

Domain names ('noms de domaine')

Conditions for protection

The domain name is protected when it is reserved and used.

Rights conferred (a) and conditions (b)

- (a) Right to prohibit use of a subsequent trade mark for identical or similar products and/or in the event of unfair advantage or dilution of reputations.
- (b) There must be a likelihood of confusion or damage to first user.

11 Croatia

11.1 Unregistered trade marks

Unregistered trade marks are protected in Croatia.
Article 6(2), (4) Croatian Trade Marks Act and the Act on Amendments to the Trade Mark Act

Conditions for protection

The unregistered trade mark must be **well-known** in the Republic of Croatia prior to the filing/priority date of the contested trade mark in the sense in which the words 'well-known' are used in Article 6^{bis} of the Paris Convention.

Rights conferred (a) and conditions (b)

- (a) Right to oppose the registration of a subsequent trade mark.
- (b) The subsequent trade mark must be identical or similar and have applied for identical or similar goods and/or services.

11.2 Other signs used in the course of trade

Earlier firm

Article 6(6) Croatian Trade Marks Act and the Act on Amendments to the Trade Mark Act

Conditions for protection

It must be registered.

Rights conferred (a) and conditions (b)

- (a) Right to oppose the registration of a subsequent trade mark.
- (b) The firm or the essential part thereof must be identical or similar to the sign in respect of which registration is sought, and the goods and/or services must be identical or similar, unless the applicant had the identical or similar firm at the time of filing the application for registration of a trade mark.

12 Italy

12.1 Unregistered trade marks

An **unregistered trade mark** ('marchio di fatto') is defined as a sign known as a trade mark or as a sign that is distinctive for manufactured goods or services on the market. Prior use must be notoriously known.

Article 12(1)(a) IT-IP CODE

Conditions for protection

The unregistered trade mark must be used to the extent that it is 'notoriously known throughout Italy or a substantial part thereof.

Rights conferred (a) and conditions (b)

- (a) Right to prohibit use of subsequent trade marks.

- (b) Identical or similar signs and identical or similar goods or services and likelihood of confusion including likelihood of association.

12.2 Other signs used in the course of trade

Article 12(1)(b) IT-IP Code

Company name, corporate name, trade name or business signs, domain name adopted by others ('ditta', 'denominazione sociale', 'ragione sociale', 'insegna', 'nome a dominio')

Conditions for protection

Used to the extent that it is 'notoriously known throughout Italy or a substantial part thereof.

Rights conferred (a) and conditions (b)

- (a) Right to prohibit use of subsequent trade mark, provided it is known by the relevant public throughout Italy or a substantial part thereof.
- (b) Identical or similar signs and identical or similar goods or services and likelihood of confusion including likelihood of association.

13 Cyprus

13.1 Unregistered trade marks

Unregistered trade marks are not recognised under the law of Cyprus.

14 Latvia

14.1 Unregistered trade marks

Unregistered trade marks are protected in Latvia.
Article 9(3) No 4 LV-TML

Conditions for protection

The unregistered mark must have been used in good faith and lawfully prior to the date of filing of the application for registration of the trade mark (or the priority date

respectively) in commercial activities in Latvia in connection with identical or similar goods or services.

Rights conferred (a) and conditions (b)

- (a) Right to prohibit subsequent trade marks.
- (b) Identical or similar signs and identical or similar goods or services; use of the subsequent trade mark must also be capable of misleading consumers as to the origin of the goods and services.

14.2 Other signs used in the course of trade

Trade names originating in Latvia or in a foreign country (**commercial designations, names of a mass medium, or other similar signs**) that are well-known in Latvia.

Article 9(3) No 3, LV-TML

Conditions for protection

The trade name must be acquired through fair and lawful use in the course of trade in Latvia before the filing/priority date of a subsequent trade mark used in an identical or similar business sector. A 'well-known' trade name must have become well known in Latvia before the filing/priority date of the subsequent trade mark.

Rights conferred (a) and conditions (b)

- (a) Right to prohibit subsequent trade marks.
- (b) The signs must be the same or confusingly similar and must cover identical or similar goods and services.

15 Lithuania

15.1 Unregistered trade marks

Article 7(1), (3), 9 LT-TML.

Conditions for protection

Unregistered trade marks are protected only if recognised as well known by a court decision.

15.2 Other signs used in the course of trade

Trade names/business names and other business identifiers

Rights conferred (a) and conditions (b)

- (a) Right to invalidate subsequent (registered) trade marks.
(b) Registration of a mark will be declared invalid if the mark is identical to a legal person's business name or is likely to be confused with a legal person's business name.

Article 7(1), No 4 LT-TML

16 Hungary

16.1 Unregistered trade marks

An unregistered trade mark is not protected under Hungarian trade mark law unless it has been used effectively in the country where use of the sign without the consent of the prior user would be contrary to law.

Article 5(2)(a) HU-TML

Article 6 of Act LVII of 1996 on the prohibition of unfair and restrictive market practices prohibits the manufacture, distribution or advertising of goods and services without the consent of competitors if the goods and services concerned have a characteristic presentation, packaging or labelling (including designation of origin), and the use of a name, mark or designation by which a competitor or its goods and services are usually recognised.

The abovementioned provisions are only an example.

17 Malta

17.1 Unregistered trade marks

Chapter 26 of Malta's Trade Mark Act; Article 6(4) MT-TMA

Conditions for protection

Protection is acquired through continuous prior use.

Rights conferred (a) and conditions (b)

- (a) Right to prohibit subsequent trade marks.
- (b) Signs must be likely to be confused and must cover identical or similar goods and services.

17.2 Other signs used in the course of trade

Article 11(3) MT-TMA

Conditions for protection

Protection is acquired through continuous use.

Rights conferred (a) and conditions (b)

- (a) Right to prohibit subsequent trade marks (Article 6(2) MT-TMA).
- (b) Likelihood of confusion.

In view of Articles 6(4) and 11(3) MT-TMA, other signs used in the course of trade are regarded as earlier rights.

18 Austria

18.1 Unregistered trade marks

Unregistered trade marks (TMs) are protected in Austria:

§ 31 Austrian Trade Mark Protection Act (1970)

Conditions for protection

An unregistered TM must have acquired a certain recognition in the course of trade ('Verkehrsgeltung') before the owner of a subsequent (registered) TM applied for registration of its TM, unless the owner of the subsequent (registered) TM has used its TM in trade without registering it for at least as long as the owner of the unregistered TM.

Rights conferred (a) and conditions (b)

- (a) Right to apply for cancellation of a subsequent (registered) TM.
- (b) The owner of the unregistered TM must not have tolerated use in trade of the subsequent registered TM during five successive years ('Verwirkung'). This applies only to those goods and/or services for which the registered trade mark

was used and only if the application for the registered trade mark was not filed in bad faith. Likelihood of confusion must be found.

18.2 Other signs used in the course of trade

§ 32 Austrian Trade Mark Protection Act (1970)

§ 9 of the Federal Act Against Unfair Competition (1984)

Corporate signs ('Unternehmenskennzeichen'), i.e. names, firms (trade names) ('Firma') or specific designations of an undertaking ('besondere Bezeichnung eines Unternehmens'), or similar designations

Conditions for protection

The entrepreneur must be the owner of the corporate sign(s).

Rights conferred (a) and conditions (b)

- (a) Right to apply for cancellation of a subsequent (registered) TM.
- (b) The entrepreneur must not have tolerated use in trade of the registered TM during five successive years ('Verwirkung'). This applies only to those goods and/or services for which the registered trade mark was used and only if the application for the registered trade mark was not filed in bad faith. Use of the trade mark could entail a likelihood of confusion in trade with one of the petitioner's aforementioned corporate signs.

Business signs ('Geschäftsabzeichen') and other facilities designed to distinguish the enterprise from other enterprises including the get-up or packaging of goods or the presentation of business stationery

Conditions for protection

The business signs must be perceived as designations of the enterprise by the market participants involved or have acquired such recognition through use ('Verkehrsgeltung').

Rights conferred (a) and conditions (b)

- (a) [Only] the right to sue the infringer to cease and desist [from such action] as well as to claim damages if the infringement was carried out with intent or in a negligent way. [In addition to the above, with registered TMs the owner also has the right to sue for cease and desist [use of its TM] and to claim damages before a civil court.]
- (b) The entrepreneur must not have tolerated use in trade of the registered TM during five successive years ('Verwirkung'). This applies only to those goods and/or services for which the registered trade mark was used and only if the application for the registered trade mark was not filed in bad faith. The trade mark

must be used in such a way that it is likely to be confused in trade with one of the entrepreneur's business signs.

19 Poland

19.1 Unregistered trade marks

Article 132(1)(ii) PL-IP Law

Conditions for protection

Unregistered trade marks (TMs) are protected only if they are well known and used in the course of trade.

Rights conferred (a) and conditions (b)

- (a) Right to prohibit the use of subsequent trade marks.
- (b) Unregistered TM must be well known and used in the course of trade; likelihood of confusion.

Additional protection is available to **well-known unregistered marks with a reputation (renowned trade mark)**. The owner of such a TM may request that the registration of a later identical or similar TM be declared invalid, irrespective of the goods or services for which it is registered, if the use thereof without due cause would take unfair advantage of, or be detrimental to, the distinctive character or repute of the earlier TM. A trade mark owner is prohibited from bringing such an action if the owner has been aware of and tolerated use of the later TM for five consecutive years.

19.2 Other signs used in the course of trade

Article 131(1), (5) PL-IP Law

Article 156(1)(i) PL-IP Law, Article 158(1) PL-IP Law

Name or address under which a person runs his business activity

Conditions for protection

Name under which a person runs their business activity.

Rights conferred (a) and conditions (b)

- (a) Right to prohibit the filing of a trade mark.

- (b) There must have been prior use of the name for business activity for identical or similar goods such as to be likely to mislead the public as to the origin of the product.

20 Portugal

20.1 Unregistered trade marks

The following unregistered trade marks (TMs) are protected in Portugal.

Unregistered TMs that are being used

Article 227 PT-IP Code

Conditions for protection

The unregistered TM must have been used in Portugal during the six months prior to the filing of an application for registration.

Rights conferred (a) and conditions (b)

- (a) Right to oppose registration of the same trade mark by other entities.
- (b) The signs and the goods and/or services must be the same.

Well-known marks

Article 241, PT-IP Code

Conditions for protection

The mark in question must be well known in Portugal.

Rights conferred (a) and conditions (b)

- (a) Right to prohibit subsequent trade marks.
- (b) The signs must be identical or similar and the goods and/or services identical or similar; likelihood of confusion or association with the holder of the earlier right must be established; the interested party must have applied for registration of the well-known mark.

Prestigious trade marks

Article 241 PT-IP Code

Conditions for protection

The mark in question must enjoy prestige in Portugal.

Rights conferred (a) and conditions (b)

- (a) Right to prohibit subsequent trade marks.
- (b) The signs must be identical or similar or, even if the goods and services are dissimilar, use of the trade mark applied for must be likely to take unfair advantage of, or be detrimental to, the distinctive character or repute of the earlier prestigious trade mark; the interested party must have applied for registration of the prestigious trade mark.

20.2 Other signs used in the course of trade

Trade names, company names

Article 239(2)(a) PT-IP Code

Rights conferred (a) and conditions (b)

- (a) Right to prohibit the use of subsequent trade marks.
- (b) The name in question must be likely to mislead or confuse the consumer.

Logotypes (name and emblem/insignia of an establishment)

(Word and figurative signs identifying an entity trading products or providing services)

Article 304-N PT-IP Code

Conditions for protection

The sign in question must be registered.

Rights conferred (a) and conditions (b)

- (a) Right to prohibit the use of subsequent signs.
- (b) The proprietor must not have given its consent, and the subsequent sign must be identical or similar to the proprietor's sign.

21 Romania

21.1 Unregistered trade marks

As a general rule, unregistered trade marks (TMs) are not protected under Romanian TM Law (Law No 84/1998 on trade marks and geographical indications). As an exception to that rule, in the case of an opposition, an unregistered trade mark may be regarded as an earlier right if it is well-known in Romania within the meaning of Article 6bis of the Paris Convention).

Article 3(d) and Article 6(2)(f) of the RO-IP Law

Conditions for protection

The unregistered TM must be well known in Romania within the meaning of Article 6bis of the Paris Convention.

Rights conferred (a) and conditions (b)

- (a) Right to prohibit the use of subsequent trade marks.
- (b) It must be well-known in Romania and there must be a likelihood of confusion.

21.2 Other signs used in the course of trade

Other signs used in the course of trade that are considered to be earlier rights are **trade names**.

Only the owner of a trade name, can oppose a trade mark or request the competent judicial body to cancel that trade mark.

Rights conferred (a) and conditions (b)

- (a) Right to prohibit subsequent trade marks. Only the owner of a trade name can oppose a trade mark or request the competent judicial body to cancel that trade mark right.
- (b) Prior use on the market.

22 Slovenia

22.1 Unregistered trade marks

Unregistered trade marks are not directly recognised under the Slovenian IP Act.

Nevertheless, under Article 44(1)(d) SL–IP Act, a sign is not eligible for registration as a mark if it is identical or similar to a mark or unregistered sign; in the Republic of Slovenia, the latter is regarded as a **well-known mark** within the meaning of Article 6bis of the Paris Convention.

22.2 Other signs used in the course of trade

Article 44(1)(f) SL–IP Act

Registered trade names (registered company names), where the term ‘company name’ is interpreted broadly and covers not only private companies such as private firms, limited liability companies, other commercial companies, and secondary trade names, but also foundations, unions, associations, museums and public institutions.

23 Slovakia

23.1 Unregistered trade marks

Article 7(f) SK-TML

Unregistered marks are defined as non-registered signs acquired and used in the course of trade prior to the filing of a subsequent application. They must be distinctive and of more than mere local significance.

Conditions for protection

The unregistered mark must have been used earlier in the course of trade of more than mere local significance and must have acquired distinctiveness through use in the course of trade in the territory of the Slovak Republic of more than mere local significance prior to the filing of the contested application.

Rights conferred (a) and conditions (b)

- (a) Right to prohibit the use of subsequent trade marks.
- (b) Signs must be identical or similar and must cover identical or similar goods and/or services

23.2 Other signs used in the course of trade

Article 7(f) SK-TML

Trade names and other related signs.

Conditions for protection

Recordal in the Register of Companies or a similar register.

These signs must have acquired distinctiveness through use in the course of trade in the territory of the Slovak Republic of more than mere local significance prior to the filing of the contested application.

Rights conferred (a) and conditions (b)

- (a) Right to prohibit the use of subsequent trade marks.
- (b) Signs must be identical or similar and must cover identical or similar goods and/or services..

24 Finland

24.1 Unregistered trade marks

Unregistered trade marks are protected in Finland:

§ 1, § 2(3), § 6, § 14(1), (6) of the Finnish Trade Mark Act (FI-TML)

Conditions for protection

Use leading to an unregistered mark becoming established on the market. A mark is considered established if it has become generally known in the appropriate business or consumer circles in Finland as a symbol specific to its proprietor's goods and/or services.

Rights conferred (a) and conditions (b)

- (a) Right to prohibit use of subsequent (registered) trade marks.
- (b) The scope of protection is identical to that of a Finnish registered trade mark, i.e. corresponding to Article 9(1)(a), (b) and (c) CTMR.

24.2 Other signs used in the course of trade

§ 1, § 2(2), 3(2), § 6, § 14(1), (6) FI-TML

Trade names (*toiminimi, firma*: any name that a natural or legal person uses in business activities), including **secondary trade names** (*aputoiminimi, bifirma*: natural or legal persons can carry out part of their business under a secondary trade name) and **secondary symbols** (*toissijainen tunnus, sekundärt kännetecken*: signs, including figurative signs, used in the course of trade).

Conditions for protection

Use leading to a trade name becoming established on the market.

Rights conferred (a) and conditions (b)

- (a) Right to prohibit subsequent trade marks.
- (b) The signs must relate to identical or similar goods and/or services and there must be a likelihood of confusion.

Trader's name

§ 1, 6, § 14(1), (6) FI-TML

Rights conferred (a) and conditions (b)

- (a) Right to prohibit subsequent trade marks.
- (b) The signs must relate to identical or similar goods and/or services and there must be a likelihood of confusion.

25 Sweden

New Swedish Trade Marks Act (2010:1877)

25.1 Unregistered trade marks

Chapter 1, Article 7 and Chapter 2, Article 8 SE-TMA

Conditions for protection

The unregistered trade mark must have been used in such a way that it has become established on the market.

Rights conferred (a) and conditions (b)

- (a) The same as for registered trade marks: right to prohibit the use of subsequent trade marks.
- (b) A mark is considered to have become established on the market when it is, within a significant portion of the circle for which it is intended, known as a symbol for the goods being made available under it.

25.2 Other signs used in the course of trade

Trade names/Company names

Chapter 1, Article 7(1); Chapter 1, Article 8; Chapter 2, Article 9 SE-TMA

Conditions for protection

The name must be registered as a company name or used in such a way that it has become established on the market. May be limited to the part of the country in which it is established on the market.

Rights conferred (a) and conditions (b)

- (a) Right to prohibit the use of subsequent trade marks.
- (b) There must be a likelihood of confusion and the signs must cover identical or similar goods and services.

26 United Kingdom

General note for unregistered signs: passing off is not in any way a 'proprietary right' that 'protects an unregistered trade mark or other sign used in the course of trade'. It refers rather to a 'wrongful invasion' of a property right, but the property protected in this case is the goodwill and reputation of a business that is likely to be harmed by misrepresentation. Whether, e.g., an opposition based on Section 5(4)(a) is successful will, then, depend on a number of cumulative factors: (demonstration and scope of goodwill; misrepresentation, damage to goodwill). On that basis, any distinction between 'protection' given to 'unregistered trade marks' and to 'other signs used in the course of trade' in the context of the UK's common-law right of 'passing off' is meaningless. The right of 'passing off' could potentially (and more often than not does) arise purely at local level (relative to the UK as a whole). (See below, 'The particularities of the action of passing off').

26.1 Unregistered trade marks

Unregistered trade marks used in the course of trade

Section 5(4)(a) UK-TMA

Conditions for protection

Must be used in the course of trade if protected by any rule of law, including that of passing off.

Rights conferred (a) and conditions (b)

- (a) Right to prohibit the use of subsequent trade marks.
- (b) **Goodwill** must be demonstrated in the UK at the relevant date, the scope of which **must extend to the goods or services** of the application; **misrepresentation as regards the 'signs'** at issue; **damage to the opponent's goodwill** can be inferred by use of the sign applied for.

26.2 Other signs used in the course of trade

Section 5(4)(a) UK-TMA

Sign used in the course of trade.

Sign used in the course of trade, protected by any rule of law, including that of passing off.

Conditions for protection

Same as under Section 26.1.

Rights conferred (a) and conditions (b)

Same as under Section 26.1.

Remarks: The Olympic Symbol Protection Act 1995 contains provisions on the exclusive use for commercial purposes of the Olympic symbol and certain words associated with the Olympic games by an individual nominated by the Secretary of State; such entitlement is not a basis for Article 8(4) CTMR.

The particularities of the action of passing off

Passing off is an economic tort in the common-law jurisdictions, the essential elements of which are (i) a misrepresentation (ii) causing damage to (iii) the goodwill of a trader or traders. It is a form of intellectual property enforcement against unauthorised use of an intellectual property right.

The purpose of this section is not to analyse the substantive requirements of passing-off actions as developed by the jurisprudence of the common-law courts but rather to set out which rights that can be protected by passing-off actions fall within the scope of Article 8(4) CTMR, and to show how the European judicature has applied the key requirements of Article 8(4) CTMR as regards passing off.

Historically, and in their most common form, passing-off actions offer protection similar to that for registered trade marks to non-registered trade marks in that they prevent use of a name, word, device or get-up that leads to the goods or services of one trader being misrepresented as those of another. In doing so, passing-off actions protect the goodwill that traders accrue by using signs rather than protecting signs per se.

The tort of passing off covers a broad set of situations ranging from its usual form above to an extended form which may prevent the use of generic terms where such use misrepresents goods or services as possessing a characteristic or quality that they do not have (e.g. Vodkat used on a type of drink that is not Vodka).

In passing-off actions, the opponent (claimant) must prove three elements, the so-called classical trinity:

- (a) **goodwill** attached to the goods or services that it supplies;
- (b) **misrepresentation** by the defendant to the public (intentional or not) leading or likely to lead the public to believe that the goods or services offered are those of the opponent (claimant);
- (c) **damage** (actual or potential) by reason of the erroneous belief engendered by the defendant's misrepresentation.

***GUIDELINES FOR EXAMINATION IN THE
OFFICE FOR HARMONIZATION IN THE
INTERNAL MARKET (TRADE MARKS AND
DESIGNS) ON COMMUNITY TRADE MARKS***

PART C

OPPOSITION

SECTION 5

***TRADE MARKS WITH REPUTATION
ARTICLE 8(5) CTMR***

Table of Contents

1	Introduction.....	4
1.1	Purpose of Article 8(5) CTMR	4
1.2	Legal framework.....	4
2	Scope of Applicability	5
2.1	Applicability to registered marks	5
2.1.1	The requirement of registration	5
2.1.2	Relationship between marks with reputation (Article 8(5) CTMR) and well-known marks (Article 8(2)(c) CTMR).....	6
2.2	Applicability to similar and identical goods and services.....	8
3	Conditions of Application	9
3.1	Earlier mark with reputation	10
3.1.1	Nature of reputation	10
3.1.2	Scope of reputation	11
3.1.2.1	Degree of recognition	11
3.1.2.2	Relevant public.....	12
3.1.2.3	Goods and services covered.....	13
3.1.2.4	Relevant territory	14
3.1.2.5	Relevant point in time	16
3.1.3	Assessment of reputation – relevant factors	18
3.1.3.1	Trade mark awareness.....	19
3.1.3.2	Market share	20
3.1.3.3	Intensity of use	22
3.1.3.4	Geographical extent of use.....	24
3.1.3.5	Duration of use	24
3.1.3.6	Promotional activities	25
3.1.3.7	Other factors.....	27
3.1.4	Proof of reputation	28
3.1.4.1	Standard of proof.....	28
3.1.4.2	Burden of proof.....	29
3.1.4.3	Evaluation of the evidence	30
3.1.4.4	Means of evidence	31
3.2	The similarity of the signs	39
3.2.1	Notion of ‘similarity’ pursuant to Article 8(5) CTMR compared with Article 8(1)(b) CTMR	40
3.3	The link between the signs	41
3.3.1	Examples where a link was found between the signs.....	43
3.3.2	Examples where no link was found between the signs.....	44
3.4	The risk of injury	46
3.4.1	Protected subject matter.....	46
3.4.2	Assessment of the risk of injury.....	47
3.4.3	Types of injury	49
3.4.3.1	Taking unfair advantage of distinctiveness or repute	50
3.4.3.2	Detriment to distinctiveness.....	56
3.4.3.3	Detriment to repute.....	60
3.4.4	Proving the risk of injury	66
3.4.4.1	Standard and burden of proof.....	66

3.4.4.2	Means of evidence	69
3.5	Use without due cause.....	69
3.5.1	Examples of due cause	70
3.5.1.1	Due cause was accepted	70
3.5.1.2	Due cause was not accepted	71

1 Introduction

1.1 Purpose of Article 8(5) CTMR

Whereas under Article 8(1)(a) CTMR double identity of signs and goods/services and under Article 8(1)(b) CTMR a likelihood of confusion are the necessary preconditions for the protection of a registered trade mark, Article 8(5) CTMR requires neither identity/similarity of goods/services nor a likelihood of confusion. Article 8(5) CTMR grants the protection for registered trade marks not only as regards identical/similar goods/services but also in relation to dissimilar goods/services without requiring any likelihood of confusion, provided the signs are identical or similar, the earlier mark enjoys a reputation and the use without due cause of the trade mark applied for would take unfair advantage of, or be detrimental to, the distinctive character or the repute of the earlier mark.

The rationale behind the extended protection under Article 8(5) CTMR is the consideration that the function and value of a trade mark are not confined to its being an indicator of origin. A trade mark can also convey messages other than an indication of the origin of the goods and services, such as a promise or reassurance of quality or a certain image of, for example, luxury, lifestyle, exclusivity etc. ('advertising function') (judgment of 18/06/2009, C-487/07 L'Oréal and others). Trade mark owners frequently invest large sums of money and effort to create a certain brand image associated with their trade mark. This image associated with a trade mark confers on it an – often significant – economic value, which is independent of that of the goods and services for which it is registered.

Article 8(5) CTMR aims at protecting this advertising function and the investment made in creating a certain brand image by granting protection to reputed trade marks, irrespective of the similarity of the goods or services or of a likelihood of confusion, provided it can be demonstrated that the use of the contested application without due cause would take unfair advantage of, or be detrimental to, the distinctive character or the repute of the earlier mark. Consequently, the main focus of Article 8(5) CTMR is not the protection of the general public against confusion as to origin, but rather the protection of the trade mark proprietor against taking unfair advantage of, or being detrimental to, the distinctive character or repute of a mark for which it has made significant investments.

1.2 Legal framework

According to **Article 8(5) CTMR**, upon opposition by the proprietor of an earlier trade mark, within the meaning of paragraph 2, the trade mark applied for shall not be registered:

where it is identical with or similar to the earlier trade mark and is to be registered for goods or services which are not similar to those for which the earlier trade mark is registered, where in the case of an earlier Community trade mark the trade mark has a reputation in the Community and, in the case of an earlier national mark, the trade mark has a reputation in the Member State concerned and where the use without due cause of the trade

mark applied for would take unfair advantage of, or be detrimental to, the distinctive character or the repute of the earlier trade mark.

The same wording is used in the parallel provisions of the **Trade Mark Directive** (Directive 2008/95/EC of the European Parliament and of the Council of 22 October 2008 to approximate the laws of the Member States relating to trade marks (Codified version), 'TMD'), namely **Article 4(3) TMD**, which deals with the protection of Community trade marks with reputation, and **Article 4(4)(a) TMD**, the equivalent provision for national marks. Even though the implementation of Article 4(4)(a) TMD was optional, all the Member States have in fact adopted provisions granting enlarged protection to national marks with reputation.

However, even in the hypothetical case that an acceding country decides not to enact an equivalent provision in its trade mark law, the independent reference to national marks with reputation in Article 8(5) CTMR means that they are **directly protected at Community level**, that is, irrespective of whether the national law grants them enlarged protection.

The wording of Article 8(5) CTMR is also very similar to the one used in **Article 9(1)(c) CTMR** and **Article 5(2) TMD**, that is, the provisions determining the exclusive rights of a trade mark proprietor, with a slight difference in the way these refer to the condition of detriment. Unlike the conditional form in Article 8(5) CTMR, which applies where use of the trade mark applied for **would take** unfair advantage of, **or be** detrimental to the distinctiveness or repute of the earlier mark', Article 9(1)(c) CTMR and Article 5(2) TMD read **takes** unfair advantage of **or is** detrimental to'. The reason for this difference is that in the first case – Article 8(5) CTMR – registrability is at stake, which may have to be decided upon without any use of the later mark having been made, while in the second case the prohibition of use is at issue. The impact of this difference on the kind of evidence required for proving detriment in either case is discussed in paragraph 3.4 below.

2 Scope of Applicability

The wording of Article 8(5) CTMR has given rise to some controversy as regards its applicability exclusively to (a) earlier registered marks and (b) dissimilar goods and services. As these issues directly affect the scope of its application, it is necessary to clarify at the outset whether it is possible to also apply Article 8(5) CTMR to (a) unregistered/well-known marks and (b) similar or identical goods and services.

2.1 Applicability to registered marks

2.1.1 The requirement of registration

Article 8(5) CTMR specifies the kinds of earlier rights on which an opposition may be based by reference to paragraph 2 of the same article, which, apart from Community, international, Benelux and national registrations or applications, includes earlier well-known marks within the meaning of Article 6^{bis} of the Paris Convention, that is, marks that may or may not be registered.

It has been argued that as a consequence of this reference, Article 8(5) CTMR should also apply to unregistered marks, at least to the extent that these have become well-

known in the relevant territory, all the more so since the protection of well-known marks against dissimilar goods and services is favoured both by Article 4(1)(b) of the WIPO Joint Recommendation Concerning Provisions on the Protection of Well-Known Marks and by Article 16(3) TRIPS.

However, such an interpretation cannot be sustained by the wording of Article 8(5) CTMR, which restricts, indirectly but clearly, its applicability to **earlier registered marks** by prohibiting registration 'where [the application] is identical or similar to the earlier trade mark and is to be registered for goods and services that are not similar to those for which the **earlier trade mark is registered**. It follows that the existence of an **earlier registration** is a **necessary condition** for the application of Article 8(5) CTMR and that, as a consequence, the reference to Article 8(2) CTMR should be limited to earlier registrations and to earlier applications subject to their registration (judgment of 11/07/2007, T-150/04, 'TOSCA BLU', para. 55).

Such a restrictive approach is not incompatible with Article 16(3) TRIPS, which also refers to an earlier registration in a very similar manner:

Article 6^{bis} of the Paris Convention (1967) shall apply, *mutatis mutandis*, to goods or services which are not similar to those in respect of which a trademark is **registered**, provided that use of that trademark ... would indicate a connection between those goods or services and the owner of the **registered** trademark and provided that the interests of the owner of the **registered** trade mark are likely to be damaged by such use. (Emphasis added)

Nor can this view be excluded by the fact that the WIPO Recommendations do not impose any conditions for granting extended protection to earlier well-known marks as they are not binding for the interpretation of the CTMR.

Therefore, Article 8(5) CTMR only applies to earlier Community, international, Benelux and national registrations, and to earlier applications, subject to their registration.

2.1.2 Relationship between marks with reputation (Article 8(5) CTMR) and well-known marks (Article 8(2)(c) CTMR)

The requirement of **registration** serves to mark the border between Article 8(5) CTMR and Article 8(2)(c) CTMR. However, neither Article 8(2)(c) CTMR nor Article 6bis of the Paris Convention stipulate expressly that the well-known mark has to be a non-registered mark. The reason for the principle that only non-registered marks are covered by these latter provisions results indirectly both from the spirit and the *ratio legis* of these provisions.

As regards the Paris Convention, the purpose of the provision of Article 6bis, introduced for the first time in the Convention in 1925, was to prevent the registration and use of a trade mark liable to create confusion with another mark already well known in the country of such registration, although the latter well-known mark was not, or not yet, protected in that country by registration.

As regards the CTMR, the purpose was to avoid a legal gap as Article 8(5) protects only registered CTMs. Without Article 8(2)(c) CTMR, reputed non-registered trade marks would have remained without protection (apart from that of Article 8(4) CTMR).

In order to avoid this legal gap, the CTMR foresaw the protection of well-known marks within the sense of Article 6bis of the Paris Convention as this article was drawn up mainly to grant protection to non-registered trade-marks with a well-known character.

Consequently, on the one hand, **well-known marks** which are **not registered** in the relevant territory cannot be protected under Article 8(5) CTMR against dissimilar goods. They can only be protected against **identical or similar goods** if there exists a likelihood of confusion pursuant to Article 8(1)(b) CTMR, to which Article 8(2)(c) CTMR refers for determining the scope of protection. However, this is without prejudice to the fact that well-known marks, to the extent they are not registered, may also be protected under Article 8(4) CTMR. Therefore, if the relevant national law affords them protection against dissimilar goods and services, such enhanced protection may also be invoked under Article 8(4) CTMR.

On the other hand, where well-known marks have been **registered**, either as CTMs, or as national marks in one of the Member States, they **can be invoked under Article 8(5) CTMR**, but only if they also **fulfil the requirements of reputation**.

Even though the terms ‘well-known’ (a traditional term used in Article 6^{bis} of the Paris Convention) and ‘reputation’ denote distinct legal concepts, there is a **substantial overlap** between them, as shown by a comparison of the way well-known marks are defined in the WIPO Recommendations with the way reputation was described by the Court in its judgment of 14/09/1999, C-375/97 ‘General Motors’ (concluding that the different terminology is merely a ‘...nuance, which does not entail any real contradiction...’, para 22).

In practical terms, the threshold for establishing whether a trade mark is well-known or enjoys reputation will usually be the same. Therefore, it will not be unusual for a mark which has acquired well-known character to have also reached the threshold laid down by the Court in *General Motors* for marks with reputation, given that in both cases the assessment is principally based on quantitative considerations regarding the degree of knowledge of the mark among the public, and that the thresholds required for each case are expressed in quite similar terms (‘known or well-known at the relevant sector of the public¹’ for well-known marks, as against ‘known by a significant part of the relevant public’ as regards marks with reputation’).

This has also been confirmed by case-law. In its judgment of 22/11/2007, C-328/06 ‘Fincas Tarragona’, the Court qualified the notions of ‘reputation’ and ‘well-known’ as kindred notions (‘notions voisines’), underlining in this way the substantial overlap and relationship between them (see para. 17). See also the judgment of 11/07/2007, T-150/04 ‘TOSCA BLU’ (paras. 56-57)

The overlap between marks with reputation and registered well-known marks has a repercussion on the raising of the ground of opposition, in the sense that it should not matter for the applicability of Article 8(5) CTMR if the opponent calls its earlier registration a well-known mark instead of a mark with reputation. For this reason, the terminology used must be carefully scrutinised, especially where the grounds of the opposition are not clearly explained, and a flexible approach should be taken where appropriate.

In the context of Article 8(2)(c) CTMR, the requirements for applying Article 6bis of the Paris Convention and Article 8(1)(a)/(b) CTMR are the same, although the terminology

¹ Article 2(2)(b) and 2(2)(c) of the WIPO Recommendations.

used is different. Both provisions require similarity or identity between the goods or services and similar or identical signs (Article 6bis uses the terms ‘reproduction’ which is equivalent to identity and ‘imitation’ which refers to similarity). Both articles also require a likelihood of confusion (‘liable to create confusion’ is the term used in Article 6bis). However, while according to Article 8(2)(c) CTMR a well-known mark can serve as an earlier right and, thus, as the **basis** of an opposition, the **grounds** for an opposition under Article 8(2)(c) CTMR are (solely) Article 8(1)(a) or (b) CTMR.

For example, if the opponent bases the opposition on (i) an earlier registration invoking Article 8(1)(b) CTMR and Article 8(5) CTMR and (ii) an identical earlier well-known mark in the same territory under Article 8(2)(c) CTMR, the earlier right must be examined:

1. under Article 8(1)(b) CTMR as an earlier **registration** with enhanced distinctiveness (in view of its well-known character);
2. under Article 8(5) CTMR, as an earlier **registration** with reputation;
3. under Article 8(2)(c) CTMR in conjunction with Article 8(1)(b) CTMR as an earlier **non-registered well-known mark** (which will only be useful if registration is not proven, as otherwise the outcome is the same as in (i) above).

Even if the opponent has not expressly based its opposition on Article 8(5) CTMR, the contents of the notice and the wording of the explanation of grounds must be carefully analysed with a view to objectively establishing whether the opponent also wants to rely on Article 8(5) CTMR.

2.2 Applicability to similar and identical goods and services

The **literal interpretation** of Article 8(5) CTMR leads to the *prima facie* conclusion that it only applies to dissimilar goods and services, as its wording provides that the mark applied for will not be registered ‘where it is identical with, or similar to, the earlier trade mark and is to be registered for **goods and services which are not similar** to those for which the earlier trade mark is registered’.

However, the above interpretation has been strongly **criticised for leaving a gap in the protection** of marks with reputation, because if protection may be granted under Article 8(5) CTMR where the goods and services are not similar, it would seem inconsistent to deny its application to similar or identical goods and services where the rest of its requirements are fulfilled and Article 8(1)(b) CTMR does not apply because there is no likelihood of confusion. In such a case trade mark owners would get more protection in the less dangerous case, that is, only where *a priori* the goods and services were not similar. For this reason, it has been suggested that Article 8(5) CTMR should also apply, directly or by analogy, where the goods and services are identical or similar.

This question with regard to the correct interpretation of the equivalent provisions of the TMD (Article 4(4)(a) and Article 5(2) TMD) was referred to the Court of Justice for a preliminary ruling (judgment of 09/01/2003, C-292/00, ‘Davidoff’).

The Advocate General in *Davidoff* suggested following the literal approach and, thus, limiting the protection afforded by Article 4(4)(a) and Article 5(2) TMD only to cases

where the goods and services of the later mark are not similar to those of the earlier mark. He considered that it was the intention of the legislator to limit the special protection granted to marks with reputation to dissimilar goods and that there was no real gap in the law worthy of interpreting the text in a manner contrary to its express wording.

However, the Court did not follow the opinion of the Advocate General and came to the opposite conclusion, namely that Article 4(4)(a) and Article 5(2) TMD should be interpreted 'as entitling the Member States to provide specific protection for registered trade marks with a reputation in cases where a later mark ... is intended to be used or is used **for goods or services identical with or similar** to those covered by the registered mark' (emphasis added, para. 30).

In reaching this conclusion, the Court observed that Article 5(2) TMD must not be interpreted solely on the basis of its wording, but also in the light of the overall scheme and objectives of the system of which it is a part. Therefore, it cannot be interpreted in a manner which would lead to marks with a reputation having less protection where a sign is used for identical or similar goods or services. The Court justified this approach as the only one consistent with its interpretation of Articles 4(1)(b) and 5(1)(b) TMD, by referring to its findings in its judgment of 11/11/1997, C-251/95 'Sabel', and its judgment of 22/06/2000, C-425/98 'Marca Mode', where it excluded a broad interpretation of the notion of confusion.

The ruling of the Court in *Davidoff*, granting extended protection under Article 4(4)(a) TMD and Article 5(2) TMD also for similar or identical goods or services, was reaffirmed in several later judgments (judgment of 23/03/2010, C-238/08, 'Google France', para. 48; judgment of 18/06/2009, C-487/07, 'L'Oreal and others', para. 35; judgment of 23/10/2003, C-408/01, 'Adidas Salomon and Adidas Benelux', para. 18).

In practice, the gap of protection closed through the inclusion of identical and similar goods under Article 8(5) CTMR will be confined to the rare cases where the signs are similar, the goods are identical or similar and the earlier mark has a reputation, but there is no likelihood of confusion within the sense of Article 8(1)(b) CTMR. As the Advocate General pointed out in his opinion, such a scenario will be quite exceptional.

3 Conditions of Application

The following conditions need be met for Article 8(5) CTMR to apply (judgment of 16/12/2010 joined cases T-345/08 and T-357/08 'BOTOCYL', confirmed by the Court of Justice in judgment of 10/05/2012 C-100/11 P):

1. earlier **registered mark with reputation** in the relevant territory;
2. **identity or similarity** between the contested CTM application and the earlier mark;
3. use of the sign applied for must be capable of taking an unfair advantage of, or being detrimental to, the distinctiveness or the repute of the earlier mark;
4. such use must be **without due cause**.

These conditions are **cumulative** and failure to satisfy any one of them is sufficient to render that provision inapplicable (judgment of 25/05/2005, T-67/04, 'SPA-FINDERS', para. 30; judgment of 22/03/2007, T-215/03, 'VIPS', para. 34; judgment of 16/12/2010 joined cases T-345/08 and T-357/08 'BOTOCYL', para. 41).

The order of the examination of these requirements may change depending on the circumstances of each case. For instance, the examination may start with the assessment of the similarities between the signs, especially in cases where there is little or nothing to say about it, either because the marks are identical or because they are patently similar or dissimilar.

3.1 Earlier mark with reputation

3.1.1 Nature of reputation

The nature and scope of reputation are not defined by either the CTMR or the TMD. Furthermore, the terms used in the different language versions of these texts are not fully equivalent, which has led to considerable confusion as to the true meaning of the term reputation, as admitted by Advocate General Jacobs in his opinion of 26/11/1998 in C-375/97 'General Motors', paras 34-36.

Given the lack of statutory definition, the Court defined the nature of reputation by reference to the purpose of the relevant provisions. In interpreting Article 5(2) TMD the Court held that the text of the TMD 'implies a **certain degree of knowledge of the earlier mark** among the public' and explained that it 'is only where there is a sufficient degree of knowledge of that mark that the public, when confronted by the later trade mark, may possibly make an association between the two trade marks ... and the earlier mark may consequently be damaged' (judgment of 14/09/1999, C-375/97 'General Motors', para. 23).

In view of these considerations, the Court concluded that reputation is a **knowledge threshold requirement**, implying that it must be principally assessed on the basis of **quantitative** criteria. In order to satisfy the requirement of reputation, the earlier mark must be known by a significant part of the public concerned by the goods or services covered by that trade mark (judgment of 14/09/1999, C-375/97 'General Motors', paras 22, 23, judgment of 25/05/2005, T-67/04 'Spa-Finders', para. 34).

Moreover, if reputation is to be assessed on the basis of quantitative criteria, arguments or evidence relating to the esteem that the public might have for the mark, rather than to its recognition, are not directly relevant for establishing that the earlier mark has acquired sufficient reputation for the purposes of Article 8(5) CTMR. However, as the economic value of reputation is also the protected subject-matter of this provision, any **qualitative aspects** thereof are relevant when assessing the possibility of detriment or unfair advantage (see also paragraph 3.4 below). Article 8(5) CTMR protects 'famous' marks not as such, but rather for the success and renown ('goodwill') they have acquired in the market. A sign does not enjoy any reputation inherently, for example, simply because it refers to a renowned person or event, but only for the goods and services it designates and the use that has been made of it.

Case No	Comment
R 0011/2008-4, 'CASAS DE FERNANDO ALONSO (fig.)'	All the evidence submitted by the opponent related to the fame of Fernando Alonso as a champion racing driver and to the use of his image made by different undertakings to promote their goods and services. However, there was no proof of reputation for the use of the earlier mark as it is registered for the relevant goods and services (paras 44, 48).
R 0201/2010-2 'BALMAIN ASSET MANAGEMENT'	The only items of evidence regarding reputation of the earlier mark submitted within the time limit, namely a page showing websites containing the word 'BALMAIN', a Wikipedia extract about the French designer Pierre Balmain and five extracts from the website www.style.com containing 'BALMAIN' wear collection, were clearly not sufficient to establish reputation of the earlier mark in the EU. Therefore, the opposition was rejected as unsubstantiated (paras 36, 37).

3.1.2 Scope of reputation

3.1.2.1 Degree of recognition

Having defined reputation as a knowledge threshold requirement, the question that necessarily follows is **how much awareness** the earlier mark must attain among the public in order to pass this threshold. The Court held in this respect that the 'degree of knowledge required must be considered to be reached when the earlier trade mark is **known by a significant part** of the public' and added that it 'cannot be inferred from either the letter or the spirit of Article 5(2) [TMD] that the trade mark must be known by a given percentage of the public' (judgment of 14/09/1999, C-375/97 'General Motors', paras 25, 26, judgment of 16/11/2011, T-500/10 'Dorma', para. 45).

By refraining from defining in more detail the meaning of the term 'significant' and by stating that the trade mark does not have to be known by a given percentage of the public, the Court in substance advised **against the use of fixed criteria** of general applicability, since a predetermined degree of recognition may not be appropriate for a realistic assessment of reputation if taken alone.

Hence, in determining whether the earlier mark is known by a significant part of the public, account must be taken not only of the degree of awareness of the mark, but also of **any other factor** relevant to the specific case. For more about the relevant factors and their interplay, see paragraph 3.1.3 below.

However, where goods or services concern quite **small groups of consumers**, the limited overall size of the market means that a significant part thereof is also restricted in absolute numbers. Hence, the limited size of the relevant market should not be regarded in itself as a factor capable of preventing a mark from acquiring a reputation within the meaning of Article 8(5) CTMR, as reputation is more a question of proportions and less of absolute numbers.

The need for the earlier mark to be known by a significant part of the public also serves to mark the difference between the notions of **reputation** as necessary condition for the application of Article 8(5) CTMR and **enhanced distinctiveness through use** as a factor for evaluating likelihood of confusion for the purposes of Article 8(1)(b) CTMR.

Even though both terms are concerned with the recognition of the mark among the relevant public, in the case of **reputation** a **threshold** exists below which extended protection cannot be granted, whereas in the case of **enhanced distinctiveness** there is **no threshold**. It follows that in the latter case any indication of enhanced recognition of the mark should be taken into account and evaluated according to its significance, regardless of whether it reaches the limit required by Article 8(5) CTMR. Therefore, a finding of 'enhanced distinctiveness' under Article 8(1)(b) CTMR will not necessarily be conclusive for the purposes of Article 8(5) CTMR.

Case No	Comment
R 1054/2007-4 'mandarino (fig.)'	The documents submitted by the opponent showed promotional efforts in such a manner that the distinctiveness is increased through use. However, the use was not enough to reach the threshold of reputation. None of the documents referred to the recognition of the earlier trade mark by the relevant end consumers, nor was evidence about the market share of the opponent's goods filed (para. 61).

3.1.2.2 Relevant public

In defining the kind of public that should be taken into account for assessing reputation, the Court held that the 'public amongst which the earlier trade mark must have acquired a reputation is **that [public] concerned by that trade mark**, that is to say, depending on the product or service marketed, either the public at large or a more specialised public, for example traders in a specific sector' (C-375/97 'General Motors', para. 24, 'SPA-FINDERS', paras 34, 41).

Hence, if the goods and services covered by the mark are **mass consumption** products, the relevant public will be the **public at large**, whereas if the designated goods have a very **specific application** or exclusively target **professional or industrial users**, the relevant public will be limited to the **specific purchasers** of the products in question.

Case No	Comment
R 1265/2010-2 'MATTONI (fig.)'	Taking into account the nature of the goods for which the opponent claims reputation, namely <i>mineral water</i> , the relevant public is the public at large (para. 44).
R 2100/2010-1 SEXIALIS	The goods for which the sign enjoys reputation are <i>medicinal preparations for the treatment of sexual dysfunction</i> . The relevant public is the general public and professionals with a high level of attention (para. 64).
Joined cases T-345/08 and T-357/08 'BOTOCYL', confirmed by C-100/11 P	The goods for which the earlier mark enjoys reputation are <i>pharmaceutical preparations for the treatment of wrinkles</i> . The evidence of the promotion of the earlier mark 'BOTOX' in English in scientific and general-interest press was sufficient to establish reputation of the mark amongst both the general public and health-care professionals (paras 65-67 in C-100/11 P). Therefore, both these categories of consumers have to be taken into account.

In addition to the actual buyers of the relevant goods, the notion of relevant public extends to the **potential purchasers** thereof, as well as to those members of the public that only come **indirectly into contact** with the mark, to the extent that such

consumer groups are also targeted by the goods in question, for instance, sports fans in relation to athletic gear, or frequent air-travellers as regards air carriers, etc.

Case No	Comment
T-47/06 'NASDAQ'	The relevant services are stock exchange price quotation services in Classes 35 and 36, which normally target professionals. The opponent submitted evidence showing that the mark 'NASDAQ' appears almost daily in many newspapers and on many television channels that can be read/viewed throughout Europe. Therefore, the Board was right to hold that the reputation of the trade mark 'NASDAQ' had to be determined for the European consumers not only among the professional public, but also to an important subsection of the general public (paras 47, 51).
T-60/10 'ROYAL SHAKESPEARE'	The evidence of reputation supports and reinforces the fact that the relevant public for <i>theatre productions</i> is the public at large and not a limited and exclusive circle. The intervener's activities were advertised, presented and commented on in numerous newspapers targeting the public at large. The intervener toured different regions throughout the United Kingdom and performed before a wide public in the United Kingdom. An activity on a large scale and, hence, a service offered to the public at large, is reflected both in the high turnover and the high box office sales. Furthermore, it is clear from the documents submitted by the intervener that the intervener received substantial annual sponsorship income from undertakings in diverse sectors which also reach the public at large, such as banks, undertakings in the alcoholic drinks sector and car manufacturers (paras 35, 36).

Quite often, a given product will concern **various purchaser groups** with different profiles, as in the case of multipurpose goods or goods that are handled by several intermediaries before they reach their final destination (distributors, retailers, end-users). In such cases the question arises whether reputation has to be assessed within each separate group or if it should cover all the different types of purchaser. The example given by the Court in C-375/97, 'General Motors', (traders in a specific sector) implies that reputation within one single group may suffice.

Likewise, if the earlier trade mark is registered for quite **heterogeneous goods** and services, different segments of the public may be concerned by each type of goods, and, therefore, the overall reputation of the mark will have to be assessed separately for each category of goods involved.

The foregoing only deals with the kind of public to be taken into account in assessing whether the earlier mark has reached the threshold of reputation laid down by the Court in *General Motors*. However, a relevant question arises when assessing detriment or unfair advantage, namely whether the earlier mark must also be known to the public concerned by the goods and services of the later mark, since otherwise it is difficult to see how the public will be in a position to associate the two. This issue is discussed in paragraph 3.4 below.

3.1.2.3 Goods and services covered

The goods and services must be first of all those for which the earlier trade mark is registered and for which reputation is claimed.

Case No	Comment
R 1473/2010-1 'SUEDTIROL'	The opposition was dismissed since the earlier marks were not registered for the services which, according to the opponent, enjoy a reputation. Article 8(5) CTMR can only be invoked if the trade mark affirmed to be well known/reowned is a registered trade mark and if the goods/services for which this reputation/reown is claimed appear on the certificate (para. 49).

The goods and services to which the evidence refers have to be identical (not only similar) to the goods and services for which the earlier trade mark is registered.

Case No	Comment
R 1033/2009-4 'PEPE'	The goods which were assessed to be reputed in Germany by the decision and order referred to only concern articles of skin and body care and children's cream. These articles are not identical to the earlier mark's goods in Class 3, <i>make-up products; nail treating products; namely nail lacquer and remover</i> . Therefore, the opponent did not prove reputation for the earlier German mark in the relevant territories (para. 31).

Where the earlier mark is registered for a wide range of goods and services targeting different kinds of public, it will be necessary to assess reputation separately for each category of goods. In such cases the earlier mark may not have a reputation for all of them, as it may not have been used at all for some of the goods, whereas for others it may not have reached the degree of knowledge necessary for the application of Article 8(5) CTMR.

Hence, if the evidence shows that the earlier mark enjoys **partial reputation**, that is, the reputation only covers some of the goods or services for which it is registered, it is only to that extent that this mark may be protected under Article 8(5) CTMR. Consequently, it is **only these goods** that may be taken into account for the purposes of the examination.

Case No	Comment
R 1588/2009-4 'PINEAPPLE'	The Board concluded that the enhanced distinctiveness and reputation of the earlier marks did not concern the opponent's G&S which were considered to be identical or similar to the contested G&S. For these G&S no enhanced distinctiveness or reputation was proven, with the exception of <i>computer software</i> in Class 9 (para. 43).
R 1466/2008-2 and R 1565/2008-2, 'COMMERZBANK ARENA'	The evidence submitted sufficiently demonstrated that the 'ARENA' brand was known by a significant part of the relevant public. However, the evidence did not include any relevant information which could allow the level of brand awareness of the 'ARENA' brand in sectors other than <i>swimwear and swimming articles</i> to be determined (paras 58, 60).

3.1.2.4 Relevant territory

According to Article 8(5) CTMR, the **relevant territory** for establishing the reputation of the earlier mark is the territory of protection: the earlier mark must **have a reputation in the territory where it is registered**. Therefore, for national marks the relevant

territory is the Member State concerned, whereas for CTMs the relevant territory is the European Union.

In *General Motors*, the Court stated that a national trade mark cannot be required to have a reputation throughout the entire territory of the Member State concerned. It is sufficient if reputation exists in a substantial part of that territory. For the Benelux territory in particular, the Court held that a substantial part thereof may consist of a part of one of the Benelux countries (judgment of 14/09/1999, C-375/97 'General Motors', paras 28, 29).

The Court has clarified that for an earlier Community trade mark reputation throughout the territory of a single Member State may suffice.

Case No	Comment
C-301/07 'PAGO'	The case concerned a Community trade mark with a reputation throughout Austria. The Court indicated that a Community trade mark must be known in a substantial part of the Community by a significant part of the public concerned by the goods or services covered by that trade mark. In view of the facts of the particular case, the territory of the Member State in question (Austria) was considered to constitute a substantial part of the territory of the Community (paras 29, 30).

In general, however, when evaluating whether the part of the territory in question is a substantial one, account must be taken both of the size of the geographical area concerned and of the proportion of the overall population living there, since both these criteria may affect the overall significance of the specific territory.

Case No	Comment
R 1283/2006-4 'RANCHO PANCHO (fig.)'	Although the evidence submitted showed use of the mark in 17 restaurants in France in 2002, this figure was considered rather low for a country of 65 million inhabitants. Therefore, the reputation was not proven (para. 22).

Opponents often indicate in the notice of opposition that the earlier mark has a reputation in an area that extends beyond the territory of protection (e.g. a pan-European reputation is alleged for a national mark). In such a case the opponent's claim must be examined with regard to the relevant territory.

Similarly, the submitted **evidence must specifically concern the relevant territory**. For example, if the evidence relates to Japan for instance, or to undefined regions, it will not be able to show reputation in the Community or in a Member State. Therefore, figures concerning sales in the Community as a whole, or world-wide sales, are not appropriate for showing reputation in a specific Member State, if the relevant data are not broken down by territory. In other words, a 'wider' reputation must also be specifically proven for the relevant territory if it is to be taken into account.

Case No	Comment
R 1718/2008-1 'LINGLONG'	Most of the documents submitted related to countries outside the European Union, mainly China, the opponent's home country, and other Asian countries. Consequently, the opponent cannot successfully claim to hold a well-known mark in the EU (para. 53).
R 1795/2008-4 'ZAPPER-CLICK' (appeal dismissed T-360/10)	The respondent sustained in the notice of cancellation that reputation was claimed for the territory of the UK. However, the international registration only designated Spain, France and Portugal and, therefore, did not extend to the territory of the UK. In addition, the respondent did not file any evidence of a reputation in the Member States designated by the international registration (para. 45).

However, where reputation is claimed as extending beyond the territory of protection and there is evidence to this effect, this must be taken into account because it may reinforce the finding of reputation in the territory of protection.

3.1.2.5 Relevant point in time

The opponent must show that the earlier mark had acquired a reputation by the **filing date** of the contested CTM application, taking account, where appropriate, of any **priority** claimed, on condition of course that the priority claim has been accepted by the Office.

In addition, the reputation of the earlier mark must subsist until the decision on the opposition is taken. However, in principle it will be sufficient for the opponent to show that its mark already had a reputation on the filing/priority date of the CTM application, while any subsequent **loss of reputation** is for the applicant to claim and prove. In practice, such an occurrence will be rather exceptional, since it presupposes a dramatic change of market conditions over a relatively short period of time.

Where the opposition is based on an **earlier application**, there is no formal obstacle for the application of Article 8(5) CTMR, which encompasses earlier applications by reference to Article 8(2) CTMR. Although in most cases the earlier application will not have acquired sufficient reputation in so short a time, it cannot be *a priori* excluded that a sufficient degree of reputation may be achieved in an exceptionally short period. In addition, the application may be for a mark which was already in use long before the application was filed and has had sufficient time to acquire a reputation. In any event, as the effects of registration are retroactive, the applicability of Article 8(5) CTMR to earlier applications cannot be regarded as a deviation from the rule that Article 8(5) CTMR only applies to earlier registrations, as concluded in paragraph 2.1 above.

In general, the **closer to the relevant date** the evidence is, the **easier** it will be to assume that the earlier mark had **acquired reputation** at that time. The evidential value of a particular document is likely to vary depending on how close the period covered is to the filing date. Evidence of reputation with regard to a later point in time than the relevant date might nevertheless allow the drawing of conclusions as to the reputation of the earlier mark at the relevant date (see, by analogy, order of 27/01/2004, C-259/02 'La Mer Technology', para. 31; judgment of 17/04/2008, C-108/07 'Ferro', para 53; judgment of 15/12/2005, T-262/04 'Shape of a lighter', para. 82).

For this reason, the materials filed with a view to proving reputation must be dated, or at least **clearly indicate when** the facts attested therein took place. Consequently, undated documents, or documents bearing a date added afterwards (e.g. hand-written dates on printed documents), are not apt for giving reliable information about the material time.

Case No	Comment
R 0055/2009-2 'BRAVIA'	The evidence showed that the mark 'BRAVIA' was used for LCD televisions in Poland, the Czech Republic, Slovakia, Hungary, Germany, Turkey, Portugal, Austria, France, Italy and the Netherlands. However, none of the documents were dated. The opponent failed to submit any information regarding duration. Therefore, the evidence, taken as whole, was insufficient to prove the reputation in the European Union (paras 27, 28).
R 1033/2009-4 'PEPE'	In the Board's view, a judgment from 1972 was not able to prove enhanced distinctiveness at the time of filing the CTM, that is, 20/10/2006. Furthermore, 'it follows from the decision of the CFI [T-164/03] that the reputation of the earlier mark has been assessed as from 13 June 1996, i.e. more than ten years before the reputation date to be taken into consideration' (para. 31).

If the **period elapsed** between the latest evidence of use and the filing of the CTM application is quite **significant**, the relevance of the evidence should be carefully assessed by reference to the kind of goods and services concerned. This is because changes in consumer habits and perceptions may take some time to happen, usually depending on the particular market involved.

For instance, the clothing market is strongly tied to yearly seasons and to the different collections issued every quarter. This will have to be taken into account in assessing a possible loss of reputation in this particular field. Likewise, the market for internet providers and e-commerce companies is very competitive and knows rapid growth, as well as rapid demise, which means that reputation in this area may be diluted faster than in other market sectors.

Case No	Comment
R 0883/2009-4 'MUSTANG'	The appellant failed to prove that its earlier mark was already well known on the application date of the contested CTM. The certificates regarding the reputation of the 'Mustang designation' refer neither to the asserted 'Calzados Mustang' figurative mark nor to the time when reputation must be determined (para. 28).

A similar question arises in the case of **evidence that post-dates the filing date** of the CTM application. Even though such evidence will not usually be sufficient on its own to prove that the mark had acquired a reputation when the CTM was filed, it is not appropriate to reject it as irrelevant either. Given that reputation is usually built up over a period of years and cannot simply be switched on and off, and that certain kinds of evidence (e.g. opinion polls, affidavits) are not necessarily available before the relevant date, as they are usually prepared only after the dispute arises, such evidence must be evaluated on the basis of its contents **and in conjunction with the rest of the evidence**. For example, an opinion poll conducted after the material time but showing a sufficiently high degree of recognition might be sufficient to prove that the mark had acquired a reputation on the relevant date if it is also shown that the market conditions

have not changed (e.g. the same levels of sales and advertising expenditure were maintained before the opinion poll was carried out).

Case No	Comment
Joined cases T-345/08 and T-357/08 'BOTOXYL', confirmed by C-100/11 P	Although the reputation of an earlier mark must be established at the filing date of the contested mark, documents bearing a later date cannot be denied evidential value if they enable conclusions to be drawn with regard to the situation as it was on that date (para. 52).

The possibility cannot automatically be ruled out that a document drawn up some time before or after that date may contain useful information in view of the fact that the reputation of a trade mark is, in general, acquired progressively. The evidential value of such a document is likely to vary depending on how close the period covered is to the filing date (see, by analogy, order of 27/01/2004, C-259/02 'La Mer Technology', para. 31; judgment of 17/04/2008, C-108/07 P 'Ferro', para. 53; judgment of 15/12/2005, T-262/04 'Shape of a lighter', para. 82).

Case No	Comment
Joined cases T-345/08 and T-357/08 'BOTOXYL', confirmed by C-100/11 P	The press articles submitted proved that there was significant media coverage of the products marketed under the trade mark BOTOX on the filing date of the disputed marks (para. 53).

3.1.3 Assessment of reputation – relevant factors

Apart from indicating that 'It cannot be inferred from either the letter or the spirit of Article 5(2) of the [TMD] that the trade mark must be known by a **given percentage** of the public', the Court also held that **all the relevant facts** must be considered in assessing the reputation of the earlier mark, '**in particular the market share** held by the trade mark, the **intensity, geographical extent** and **duration** of its use, and the **size of investment** made by the undertaking in promoting it' (judgment of 14/11/1999, C-375/97 'General Motors', paras 25, 27).

If these two statements are taken together, it follows that the level of knowledge required for the purposes of Article 8(5) CTMR cannot be defined in the abstract, but should be evaluated on a **case-by-case** basis, taking into account **not only the degree of awareness of the mark, but also any other fact relevant to the specific case**, that is, any factor capable of giving information about the performance of the mark in the market.

The list of factors to be taken into consideration in order to ascertain the reputation of an earlier mark (such as the market share held by the trade mark, the intensity, geographical extent and duration of its use, and the amount spent by the undertaking in promoting it) only serve as examples.

Case No	Comment
T-47/06 'Nasdaq'	<p>The opponent provided detailed evidence relating to the intensity, geographical extent and duration of the use of its trade mark NASDAQ and the amount spent in promoting it, demonstrating that it was known by a significant part of the public concerned by it. The Court considered that the fact that it did not produce figures regarding the market share did not call this finding into question (para. 51).</p> <p>The Court concluded that the list of factors to be taken into consideration in order to ascertain the reputation of an earlier mark only serve as examples, as all the relevant evidence in the case must be taken into consideration and, second, the other detailed and verifiable evidence produced by the intervener is already sufficient in itself to conclusively prove the reputation of its mark NASDAQ (para. 52).</p>

Moreover, the relevant factors should be assessed with a view not only to establish the degree of recognition of the mark amongst the relevant public, but also to ascertain whether the **other requirements** related to reputation are fulfilled, for example, whether the alleged reputation covers a significant part of the territory concerned or whether the reputation had indeed been acquired by the filing/priority date of the contested CTM application.

The same kind of test is applied to ascertain whether the trade mark has acquired **enhanced distinctiveness** through use for the purposes of Article 8(1)(b) CTMR, or whether the mark is **well-known** within the meaning of Article 6^{bis} of the Paris Convention, since the subject-matter of proof in all these cases is in substance the same, namely the degree to which the mark is known by the relevant public, without prejudice to the threshold required in each case.

3.1.3.1 Trade mark awareness

The statement of the Court that 'it is not necessary for the mark to be known by a given percentage of the public', cannot be taken in itself as meaning that figures of trade mark awareness are irrelevant for, or that they should be given a lower probative value in, the assessment of reputation. It only implies that percentages of awareness defined in the abstract may not be appropriate for all cases and that, consequently, it is **not possible to fix a priori a generally applicable threshold of recognition** beyond which it should be assumed that the mark is reputed (see, to that effect and by analogy, judgment of 04/05/1999, joined cases C-108/97 and C-109/97 'Windsurfing Chiemsee', para. 52; judgment of 22/06/1999, C-342/97 'Lloyd Schuhfabrik Meyer', para. 24, judgment of 16/11/2011 T-500/10, 'DORMA', para. 52).

Therefore, even though not expressly listed by the Court among the factors to be taken into account for assessing reputation, the **degree of recognition** of the mark amongst the relevant public is **directly relevant** and can be particularly helpful in evaluating whether the mark is sufficiently known for the purposes of Article 8(5) CTMR, provided of course that the method of its calculation is reliable.

As a rule, the **higher the percentage** of trade mark awareness, the **easier** it will be to accept that the **mark has a reputation**. However, in the absence of a clear threshold, only if the evidence shows a **high degree** of trade mark awareness, will percentages of recognition be **persuasive**. Percentages alone are not conclusive. Rather, as explained before, reputation has to be evaluated by making an overall assessment of

all the factors relevant to the case. The higher the degree of awareness, the less additional evidence may be required to prove reputation and vice versa.

Case No	Comment
R 0765/2009-1 'BOB THE BUILDER (fig.)'	The evidence submitted proved that the earlier mark enjoyed a very significant reputation in Sweden for <i>jellies, jams, fruit stews, fruit drinks, concentrates for production of drinks and juice</i> . According to the survey conducted by TNS Gallup, the spontaneous awareness (answers by telephone to the question 'What brands for – 'the relevant group of products is mentioned' – have you heard about or do you know about?') for the trade mark 'BOB' varied between 25 and 71% depending on the goods: <i>apple sauces, jams, marmalades, soft drinks, fruit drinks and fruit juices</i> . The supported awareness (answer to a questionnaire showing the products bearing the mark) varied between 49 and 90% depending on the goods. Furthermore, the market share for 2001 to 2006 averaged 30-35% in the above product groups (para. 34).

Where the evidence shows that the mark only enjoys a **lesser degree of recognition**, it should not be automatically assumed that the mark is reputed, which means that, most of the time, **mere percentages will not be conclusive** in themselves. In such cases, only if the evidence of awareness is coupled with sufficient indications of the overall performance of the mark in the market will it be possible to evaluate with a reasonable degree of certainty whether the mark is known by a significant part of the relevant public.

3.1.3.2 Market share

The **market share** enjoyed by the goods offered or sold under the mark and the **position** it occupies in the market are valuable indications for assessing reputation, as they both serve to indicate the **percentage of the relevant public that actually buys** the goods and to measure the success of the mark against competing goods.

Market share is defined as the **percentage of total sales** obtained by a brand in a particular sector of the market. When defining the relevant market sector, the goods and services for which the **mark has been used** must be taken into account. If the scope of such goods and services is narrower than those for which the mark is registered, a situation of partial reputation arises, similar to the one where the mark is registered for a variety of goods, but has acquired a reputation only for part of them. This means that in such a case, only **the goods and services for which the mark has actually been used and acquired a reputation will** be taken into account for the purposes of the examination.

Therefore, a very **substantial market share**, or a **leader position** in the market, will usually be a **strong indication of reputation**, especially if combined with a reasonably high degree of trade mark awareness. Conversely, a **small market share** will in most cases be an **indication against reputation**, unless there are other factors which suffice on their own to support such a claim.

Case No	Comment
Joined cases T-345/08 and T-357/08 'BOTOCYL', confirmed by C-100/11 P	'... the size of the market share of BOTOX in the United Kingdom, 74.3% in 2003 , like the degree of awareness of the trade mark of 75% among the specialised public accustomed to pharmaceutical treatments against wrinkles, is sufficient to substantiate the existence of a considerable degree of recognition on the market' (para. 76).
T-08/03 'Emilio Pucci'	The CFI considered that the opponent failed to prove the enhanced distinctiveness or reputation of its earlier trade marks, since the evidence submitted (advertisements, seven letters from a number of advertising directors and a video cassette) did not include adequately substantiated or verifiable objective evidence to make it possible to assess the market share held by the marks EMIDIO TUCCI in Spain, how intensive, geographically widespread and long-standing use of the marks had been or the amount invested by the undertaking in promoting them (para. 73).

Another reason why a **moderate market share will not always be conclusive against reputation** is that the percentage of the public that in reality knows the mark may be much higher than the number of actual buyers of the relevant goods. This would be the case, for example, for goods that are normally used by more than one user (e.g. family magazines or newspapers) (judgment of 06/07/2012, T-60/10, 'ROYAL SHAKESPEARE' paras 35, 36 and judgment of 10/05/2007, T-47/06 'NASDAQ' paras 47, 51) or for luxury goods, which many may know, but few can buy (e.g. a high percentage of European consumers know the trade mark 'Ferrari' for cars, but only few own one). For this reason, the market share proved by the evidence should be assessed taking into account the particularities of the specific market.

Case No	Comment
R 1659/2011-2 'KENZO'	'KENZO' identifies, in the eyes of the European public, a pre-eminent provider of recognised fashion and luxury items in the form of perfumes, cosmetics and clothing. The relevant public however was considered to be the general public (para. 29).

In certain cases it will **not be easy to define the market share** of the earlier mark, for example when the exact size of the relevant market cannot be measured accurately, owing to peculiarities of the goods or services concerned.

Case No	Comment
R 0446/2010-1 'TURBOMANIA'	The limited presence of the product on the market by no means prevented it from becoming well known by the relevant public. The evidence clearly showed that the trade mark appeared continuously in specialist magazines for the market from December 2003 to March 2007 (the date of the Community trade mark application). That meant that the public targeted by the magazines had constant, on-going exposure to the opponent's trade mark over a long period covering more than three years prior to the relevant date. Such a huge presence in the press specifically targeting the relevant public was more than sufficient evidence that the relevant public was aware of the trade mark (para. 31).

In such cases, **other similar indications** may be relevant, such as TV audience rates, as in the case of motor racing and other sporting or cultural events.

Case No	Comment
T-47/06 'NASDAQ'	The opponent submitted evidence showing that the mark 'NASDAQ' appeared almost daily, particularly by reference to the Nasdaq indices, in many newspapers and on many television channels that can be read/viewed throughout Europe. The opponent also submitted evidence of substantial investments in advertising . The Court found reputation proven, even though the opponent did not submit any market share figures (paras 47-52).

3.1.3.3 Intensity of use

The intensity of use of a mark may be demonstrated by **sales volumes** (i.e. the number of units sold) and **turnover** (i.e. the total value of those sales) attained by the opponent for goods bearing the mark. Usually, the relevant figures correspond to sales in one year, but there may be cases where the time unit used is different.

Case No	Comment
R 2100/2010-1 'SEXIALIS'	The documents submitted (press articles, sales figures, surveys) showed that the earlier sign 'CIALIS' was intensively used before the filing date of the CTM application, that the products under the mark 'CIALIS' were marketed in several Member States where they enjoyed a consolidated position among the leading brands, and that there was a high degree of recognition in comparison to the market leader 'VIAGRA'. Large and constantly growing market share and sales numbers also showed 'the vast expansion of 'CIALIS'' (para. 55).

In evaluating the importance of a given turnover or sales volume, account should be taken of **how large the relevant market is in terms of population**, as this has a bearing on the number of potential purchasers of the products in question. For example, the relative value of the same number of sales will be much bigger, for example, in Luxembourg than in Germany.

Moreover, whether or not a given sales volume or turnover is substantial will depend on the **kind of product** concerned. For example, it is much easier to achieve a high sales volume for everyday, mass consumption goods than for luxury or durable products that are bought rarely, without this meaning that in the former case more consumers have come into contact with the mark, as it is likely that the same person has bought the same product more than once. It follows that the **kind, value and durability** of the goods and services in question should be taken into consideration in determining the significance of a given sales volume or turnover.

Figures of turnover and sales will be more useful as **indirect indications** that should be assessed in conjunction with the rest of the evidence, rather than as direct proof of reputation. In particular, such indications can be especially helpful for **completing the information given by percentages** as regards market share and awareness, by giving a more **realistic impression** of the market. For example, they may reveal a very large amount of sales behind a not-so-impressive market share, which may be useful in assessing reputation in the case of competitive markets, where it is in general more difficult for a single brand to account for a substantial portion of the overall sales.

In contrast, where the market share of the products for which the mark is used is not given separately, it will not be possible to determine whether a given turnover corresponds to a substantial presence in the market or not, unless the opponent also submits evidence showing the **overall size of the relevant market in terms of money**, so that its percentage in it may be inferred.

Case No	Comment
R 1054/2007-4 'mandarino' (fig.)	The reputation was not sufficiently proven in particular because none of the documents referred to the recognition of the earlier trade mark by the relevant end consumers. Nor was any evidence about the market share of the opponent's goods submitted. Information about the market share is particularly important in the sector in which the opponent had its core business (<i>handbags, transport items, accessories and clothing</i>) which is 'a quite atomized and competitive sector' and there are many different competitors and designers in that product range (paras 59-61).

This does not mean that the importance of turnover figures or volume of sales should be underestimated, as both are significant indications of **the number of consumers** that are expected to have encountered the mark. Therefore, it **cannot be excluded** that a **substantial** amount of turnover or sales volume may, in certain cases, be **decisive** for a finding of reputation, either alone, or in conjunction with very little other evidence.

Case No	Comment
R 0445/2010-1 'FLATZ'	Although, for reasons of force majeure, it was not possible for the earlier trade mark to become well known by traditional methods, that is, through selling the product, it did become extremely well known as a result of promotional activities, by publicising the trade mark extensively, continually and constantly in the specialist press and at sectorial fairs, thereby reaching virtually the whole of the three relevant sectors of the public. The limited presence of the product on the market by no means prevented it from becoming well known by the relevant public that, on the relevant date, FLATZ was the trade mark with which the opponent identified its <i>electronic bingo machines</i> (paras 41, 42, 50, 51).
R 1466/2008-2 and R1565/2008-2, 'COMMERZBANK ARENA'	The lack of figures regarding the market share held by the trade mark 'ARENA' in the relevant countries was not in itself capable of calling the finding of reputation into question. First, the list of factors to be taken into consideration in order to ascertain the reputation of an earlier mark only serves to illustrate examples, as all the relevant evidence in the case must be taken into consideration and, second, the other detailed and verifiable evidence submitted by the opponent is already sufficient in itself to prove conclusively the substantial degree of recognition of the 'ARENA' mark amongst the relevant public (para. 59).

However, as this would deviate from the rule that reputation has to be evaluated by making an overall assessment of all factors relevant to the case, findings of reputation based almost exclusively on such figures should be generally avoided, or at least confined to exceptional cases that would really justify such a finding.

3.1.3.4 Geographical extent of use

Indications of the territorial extent of use are mainly useful for determining whether the alleged reputation is **widespread enough to cover a substantial part** of the relevant territory, within the sense given in paragraph 3.1 above. In this assessment, account should be taken of the density of population in the respective areas, as the critical criterion is the proportion of consumers knowing the mark, rather than the size of the geographical area as such. Similarly, what is important is public awareness of the mark rather than availability of goods or services. A mark may, therefore, have a territorially widespread reputation on the basis of advertising, promotion, media reports, etc.

In general, the more widespread the use, the easier it will be to conclude that the mark has passed the required threshold, whereas any indication showing use beyond a substantial part of the relevant territory will be a positive sign in the direction of reputation. Conversely, a very limited amount of use in the relevant territory will be a strong indication against reputation, as for example where the vast majority of the goods are exported to a third jurisdiction in sealed containers, directly from their place of production.

Case No	Comment
R 0966/2010-1 'ERT (fig.)'	If the earlier mark were so well known in the 27 Member States of the EU for TV broadcasting and magazines, it should have been easy for the opponent to provide information about 'the reach of the mark' just before 2008, when the CTM application was filed. The magazine sales figures did not cover the right period. The submitted documents did not give any indication of the extent to which the public was aware of the mark (paras 16, 18).

However, evidence of actual use in the relevant territory should not be regarded as a necessary condition for the acquisition of reputation, as what matters most is knowledge of the mark and not how it was acquired.

Such knowledge may be generated by, for example, intensive advertising prior to the launching of a new product, or in the case of important cross-border shopping it may be fuelled by a significant price difference in the respective markets, a phenomenon often referred to as **'territorial spill-over' of reputation** from one territory to another. However, when it is claimed that such circumstances have occurred, the corresponding evidence must demonstrate this. For example, it cannot be assumed, merely because of the principle of free trade in the European Union, that goods put in the market in Member State X have also penetrated the market of Member State Y in significant numbers.

3.1.3.5 Duration of use

Indications of the duration of use are particularly useful for determining the **longevity** of the mark. The longer the mark has been used in the market, the larger will be the number of consumers that are likely to have encountered it, and the more likely it is that such consumers will have encountered the mark more than once. For example, a market presence of 45, 50 or 100-plus years is considered a strong indication of reputation.

Case No	Comment
R 1466/2008-2 and R 1565/2008-2, 'COMMERZBANK ARENA'	The evidence submitted showed a particularly impressive duration of use (over thirty years) and geographical extent of use (over seventy-five countries worldwide, including the Member States concerned) of the 'ARENA' brand (para. 55).
T-369/10 'BEATLE' (appeal dismissed in C-294/12 P)	The Beatles group was considered to be a group with an exceptional reputation lasting for more than 40 years (para. 36).

The duration of use of the mark should not be inferred by mere reference to the term of its registration. Registration and use do not necessarily coincide, as the mark may have been put to actual use either before or after it was filed. Therefore, where the opponent invokes actual use, going beyond the term of registration, it must prove that such use actually began before it applied for its mark.

Nevertheless, a long registration period may sometimes serve as an indirect indication of a long presence on the market, as it would be unusual for a proprietor to maintain a registered mark for many decades without any economic interest behind it.

In the end, the decisive element is whether the earlier mark had acquired a reputation at the time of filing of the contested application. Whether that reputation also existed at some earlier point in time is legally irrelevant. Therefore, evidence of **continuous use up to the filing date** of the application will be a positive indication in the direction of reputation.

In contrast, if the **use of the mark was suspended** over a significant period, or if the period elapsed between the latest evidence of use and the filing of the CTM application is quite long, it will be more difficult to conclude that the reputation of the mark survived the interruption of use, or that it subsisted until the filing date of the application (see paragraph 3.1.2.5 above).

3.1.3.6 Promotional activities

The **nature** and **scale of the promotional activities** undertaken by the opponent are useful indications in assessing the reputation of the mark, to the extent that these activities were undertaken to build-up a brand image and enhance trade mark awareness among the public. Therefore, **a long, intensive and widespread** promotional campaign may be a **strong indication** that the mark has acquired a reputation among the potential or actual purchasers of the goods in question, and may actually have become known beyond the circle of the actual purchasers of those goods.

Case No	Comment
C-100/11 P 'BOTOCYL'	Evidence of the promotion of 'BOTOX' in English in scientific and general-interest press was sufficient to establish reputation of the mark both amongst the general public and amongst health-care professionals (paras 65, 66).

Case No	Comment
R 0445/2010-1 'FLATZ'	Although, for reasons of force majeure, it was not possible for the earlier trade mark to become well known by traditional methods, that is, through selling the product, it did become extremely well known as a result of promotional activities, by publicising the trade mark extensively, continually and constantly in the specialist press and at sectorial fairs, thereby reaching virtually the whole of the three relevant sectors of the public. The limited presence of the product on the market by no means prevented it from becoming well known by the relevant public that, on the relevant date, FLATZ was the trade mark with which the opponent identified its <i>electronic bingo machines</i> (paras 41, 42, 50, 51).
R 1659/2011-2 'KENZO' and R 1364/2012-2 'KENZO'	The opponent's goods have been advertised and articles have been written about them in many of the world's leading fashion-related lifestyle magazines, and in some of Europe's leading mainstream periodicals. In line with the case-law, the reputation of 'KENZO' for the said goods is confirmed. The goods for which the earlier mark has reputation are cosmetics, perfumes and clothing. Because of its substantial reputation, the earlier mark 'KENZO' possesses an 'undisputable allure' that can be transferred to nearly any luxury product (para. 33). Subsequent case confirmed reputation (para. 33).

Even though it cannot be ruled out that a mark acquires a reputation before any actual use, promotional activities will usually not be sufficient on their own for establishing that the earlier mark has indeed acquired a reputation (see paragraph 3.1.3.4 above). For example, it will be difficult to prove knowledge amongst a significant part of the public exclusively by reference to promotion or advertising, carried out as preparatory acts for the launching of a new product, as the actual impact of publicity on the perception of the public will be difficult to measure without reference to sales. In such situations, the only means of evidence available to the opponent are opinion polls and similar instruments, the probative value of which may vary depending of the reliability of the method used, the size of the statistical sample etc. (for the probative value of opinion polls, see paragraph 3.1.4 below).

The impact of the opponent's promotional activities may be shown either **directly**, by reference to the **amount of promotional expenditure**, or **indirectly**, by way of inference from the **nature of the promotional strategy** adopted by the opponent and **the kind of medium used** for advertising the mark.

For example, advertising on a nation-wide TV channel or in a prestigious periodical should be given more weight than campaigns of a regional or local scope, especially if coupled with high audience or circulation figures. Likewise, the sponsoring of prestigious athletic or cultural events may be a further indication of intensive promotion, as such schemes often involve a considerable investment.

Case No	Comment
R 1673/2008-2 'FIESTA'	It is apparent from Ferrero's various advertising campaigns on Italian television (including Rai) that the earlier mark was widely exposed to viewers in 2005 and 2006. Many of these spots appear to have been broadcast in peak viewing times (e.g. during Formula 1 Grand Prix coverage) (para. 41).

Furthermore, the **contents of the advertising strategy** chosen by the opponent can be useful for revealing the **kind of image** the opponent is trying to create for its brand. This may be of particular importance when assessing the possibility of detriment to, or of taking unfair advantage of, a particular image allegedly conveyed by the mark, since the existence and contents of such an image must be abundantly clear from the evidence submitted by the opponent (see paragraph 3.4 below).

Case No	Comment
T-332/10 'VIAGUARA' ('VIAGRA')	The General Court found that in regard to the nature of the goods concerned, the BoA rightly considered that the aphrodisiac and stimulating properties claimed for commercial purposes for the non-alcoholic beverages covered by Class 32 coincide with the therapeutic indications of the earlier mark's goods or at least with the images it projects, namely an image of pleasure, vitality, strength and youth (para. 66).
R 0306/2010-4 'CARRERA' (under appeal T-0173/11)	The opponent's trade mark is not only known per se, but due to the high price of sports cars and the opponent's intensive expenditure on advertising and against the background of its successes in racing, the public associates it with an image of luxury, high tech and high performance (para. 31).

3.1.3.7 Other factors

The Court has made clear that the above list of factors is only indicative and has underlined that all the facts relevant to the particular case must be taken into consideration in assessing the reputation of the earlier mark (judgment of 14/09/1999, C-375/97 'General Motors', para. 27). Other factors may be found in the case-law of the Court dealing with enhanced distinctiveness through use, or in the WIPO Recommendations on the protection of well-known marks. Therefore, depending on their relevance in each case, the following may be added to the above factors: record of successful enforcement; number of registrations; certifications and awards; and the value associated with the mark.

Record of successful enforcement

Records of successful enforcement of a mark against dissimilar goods or services are important because they may demonstrate that, at least in relation to other traders, there is acceptance of protection against dissimilar goods or services.

Such records may consist of successful prosecution of complaints outside the courts, such as acceptance of cease and desist requests, delimitation agreements in trade mark cases, and the like.

Furthermore, evidence showing that the reputation of the opponent's mark has been repeatedly recognised and protected against infringing acts by **decisions of judicial or administrative authorities** will be an important indication that the mark enjoys a reputation in the relevant territory, especially where such decisions are recent. That effect may be reinforced when the decisions of this kind are substantial in number (on the probative value of decisions, see paragraph 3.1.4.4 below). This factor is mentioned in Article 2(1)(b)(5) of the WIPO Recommendations.

Number of registrations

The **number** and **duration of registrations** and applications of the mark around Europe or the world is also relevant, but in itself it is a weak indication of the degree of recognition of the sign by the relevant public. The fact that the opponent has many trade mark registrations and in many classes may indirectly attest to an international circulation of the brand, but cannot be decisively prove in itself a reputation. This factor is mentioned in Article 2(1)(b)(4) of the WIPO Recommendations, where the need of actual use is made clear: the duration and geographical area of any registrations, and/or any applications for registration, of the mark are relevant ‘to the extent that they reflect use or recognition of the mark’.

Certifications and awards

Certifications, awards, and similar public recognition instruments usually provide information about the history of the mark, or reveal certain quality aspects of the opponent’s products, but as a rule they will not be sufficient in themselves to establish reputation and will be more useful as indirect indications. For example, the fact that the opponent has been a holder of a royal warrant for many years may perhaps show that the mark invoked is a traditional brand, but cannot give first-hand information about trade mark awareness. However, if the certification concerns facts that are related to the performance of the mark, its relevance will be much higher. This factor is mentioned by the Court in ‘Lloyd Schuhfabrik Meyer’ and ‘Windsurfing Chiemsee’ in relation to the assessment of enhanced distinctiveness through use.

Case No	Comment
R 1637/2011-5 ‘APART’	The new evidence submitted by the appellant and accepted by BoA shows that the earlier mark had consistently been granted a high brand rating as well as prizes in surveys carried out by specialised companies in Poland between 2005 and 2009 (para. 30). It was therefore considered that the appellant successfully proved reputation in Poland for jewellery, but did not prove reputation for the other goods and services covered by its earlier signs.

The value associated with the mark

The fact that a mark is solicited by third companies for reproduction on their products, either as a trade mark, or as mere decoration, is a strong indication that the mark possesses a high degree of attractiveness and an important economic value. Therefore, the extent to which the mark is exploited through **licensing, merchandising and sponsoring**, as well as the importance of the respective schemes, are useful indications in assessing reputation. This factor is mentioned in Article 2(1)(b)(6) of the WIPO Recommendations.

3.1.4 Proof of reputation

3.1.4.1 Standard of proof

The opponent must submit evidence enabling the Office to reach a **positive finding** that the earlier mark has acquired a reputation in the relevant territory. The wording

used in Article 8(5) CTMR and Rule 19(2)(c) CTMIR is quite clear in this respect: the earlier mark deserves enlarged protection only if it 'has a reputation'.

It follows that the **evidence must be clear and convincing**, in the sense that the opponent must clearly establish all the facts necessary to safely conclude that the mark is known by a significant part of the public. The reputation of the earlier mark must be established to the satisfaction of the Office and not merely assumed.

3.1.4.2 Burden of proof

According to the second sentence of Article 76(1) CTMR, in *inter partes* proceedings the Office is restricted in its examination to the facts, evidence and arguments provided by the parties. It follows that in assessing whether the earlier mark enjoys reputation, the Office may **neither take into account** facts known to it as a result of its own **private knowledge** of the market **nor conduct an ex-officio investigation**, but should exclusively base its findings on the information and evidence submitted by the opponent.

Exceptions to this rule apply where particular facts are so well-established that they can be considered as universally known and, thus, are also presumed to be known to the Office (e.g. the fact that a particular country has a certain number of consumers, or the fact that food products target the general public). However, whether or not a mark has passed the threshold of reputation established by the Court in *General Motors* is not in itself a pure question of fact, since it requires the legal evaluation of several factual indications, and, as such, the reputation of the earlier mark may not be simply assumed to be a universally known fact.

Case No	Comment
T-185/02 'PICARO' (confirmed by C-361/04 P)	The Board of Appeal, in addition to the facts expressly put forward by the parties, may take into consideration facts which are well known, that is, which are likely to be known by anyone or which may be learnt from generally accessible sources. 'It must be borne in mind, at the outset, that the legal rule stated in Article 76(1) in fine of Regulation No 40/94 constitutes an exception to the principle of examination of the facts by OHIM of its own motion, laid down in limine by that provision. That exception must therefore be given a strict interpretation, defining its extent so as not to exceed what is necessary for achieving its object' (paras 29-32).
R 1472/2007-2 'El Polo'	It is common knowledge that the earlier mark is indeed a very famous brand, not only in France, but in most European countries, in large part due to the public's exposure to products at airport and duty free boutiques as well as long-standing advertising in widely circulated magazines. The weight of evidence required to support statements which are universally known to be true need not be great (para. 32).

Rule 19(2)(c) CTMIR provides that the burden of putting forward and proving the relevant facts lies with the opponent, by expressly requiring it to provide 'evidence attesting that the earlier mark **has a reputation**'. According to Rule 19(1) and Rule 19(2)(c) CTMIR and Office practice, such evidence may be submitted either together with the notice of opposition, or subsequently within four months of the date of notification of the opposition to the applicant. The opponent may also refer to facts and evidence submitted in the course of another opposition, provided that the relevant

materials are indicated in a clear and unambiguous way and that the language of proceedings is the same in both cases.

If the evidence of reputation is not in the correct **language**, it will have to be translated into the language of the proceedings within the same period of four months, as required by Rules 16(1) and 17(3) CTMR. However, in view of the volume of documents often needed for proving reputation, it is sufficient to translate only the material parts of long documents or publications. Similarly, it is not necessary to translate in their entirety documents or parts of documents that contain mainly figures or statistics, the meaning of which is evident, as is often the case with invoices, order forms, diagrams, brochures, catalogues etc.

Case No	Comment
R 1472/2007-2 'El Polo'	Although there is a requirement to adduce evidence to substantiate the existence of an earlier right in the language of the opposition proceedings, it is not specified that such translations have to be in any specific format. Many opponents simply provide their own, often hand-written, translations of the registration details. It is primarily for the Office and, to a lesser extent, for the applicant to check the accuracy of these translations. If a translation is incorrect, the document cannot be relied upon (para. 17).

3.1.4.3 Evaluation of the evidence

The basic rules on the evaluation of evidence are also applicable here: the evidence should be assessed **as a whole**, that is, each indication should be weighed-up against the others, whereas information confirmed by more than one source will generally be more reliable than facts derived from isolated references. Moreover, the more independent, reliable and well-informed the source of the information is, the higher the probative value of the evidence will be.

Therefore, information **deriving directly from the opponent** is unlikely to be enough on its own, especially if it only consists of **opinions** and **estimates** instead of facts, or if it is of an **unofficial character** and lacks objective confirmation, as for example when the opponent submits internal memoranda or tables with data and figures of unknown origin.

Case No	Comment
R 0295/2009-4 'PG PROINGEC CONSULTORIA (fig.)'	The content of the documentation submitted does not clearly demonstrate that the earlier marks enjoy a reputation. The documentation emanates, in the main, from the respondent directly and contains information taken from the respondent's trade catalogues, and its own advertising and documents downloaded from its website. There is insufficient documentation/information from third parties to reflect clearly and objectively what the respondent's position on the market precisely is. Reputation not proved (para. 26).

Case No	Comment
T-500/10 'doorsa FÁBRICA DE PUERTAS AUTOMÁTICAS' (fig.)	As regards documents in the case-file which come from the company itself, the General Court has held that to assess the evidential value of such a document, first and foremost account should be taken of the credibility of the account it contains. The Court added that it is then necessary to take account, in particular, of the person from whom the document originates, the circumstances in which it came into being, the person to whom it was addressed and whether, prima facie, the documents appear sound and reliable (para. 49).

However, if such information is publicly available or has been compiled for official purposes and contains information and data that have been objectively verified, or reproduces statements made in public, its probative value is generally higher.

As regards its contents, the more indications the evidence gives about the various factors from which reputation may be inferred, the more relevant and conclusive it will be. In particular, evidence which as a whole gives **little or no quantitative data and information** will not be appropriate for providing indications about **vital factors**, such as trade mark awareness, market share and intensity of use and, consequently, will not be sufficient to support a finding of reputation.

3.1.4.4 Means of evidence

There is no direct indication in the Regulations as to which kind of evidence is more appropriate for proving reputation, as for instance the one in Rule 22(4) CTMIR about evidence of use. The opponent may avail itself of **all the means of evidence of Article 78(1) CTMR**, provided they are capable of showing that the mark has indeed the required reputation.

The following means of evidence are more frequently submitted by opponents in Opposition proceedings before the Office (this list does not reflect their relative importance or probative value):

1. sworn or affirmed statements
2. decisions of Courts or Administrative authorities
3. decisions of the Office
4. opinion polls and market surveys
5. audits and inspections
6. certifications and awards
7. articles in the press or in specialised publications
8. annual reports on economic results and company profiles
9. invoices and other commercial documents
10. advertising and promotional material.

Evidence of this kind may also be submitted under Article 8(1)(b) CTMR in order to prove that the earlier mark has obtained a higher degree of distinctiveness, or under Article 8(2)(c) CTMR in relation to well-known marks.

Sworn or affirmed statements

The weight and probative value of statutory declarations is determined by the general rules applied by the Office to the assessment of such evidence. In particular, both the capacity of the person giving the evidence and the relevance of such evidence to the particular case must be taken into account. For further details on the weight and probative value of affidavits, see the Guidelines, Part C, Opposition, Section 6, Proof of Use.

Case No	Comment
R 0729/2009-1 'SKYBLOG'	The statement submitted by an expert consultancy firm in the area of digital media strategy in the UK attests to the opponent 'as the leading supplier of digital television in the UK' and that 'Sky' has an enormous and impressive reputation (para. 37).

Decisions of Courts or Administrative authorities

Opponents often invoke decisions of national authorities or Courts which have accepted the reputation of the earlier mark. Even though national decisions are admissible evidence and may have evidentiary value, especially if they originate from a Member State the territory of which is also relevant for the opposition at hand, they are not binding for the Office, in the sense that it is not mandatory to follow their conclusion.

Case No	Comment
T-0192/09 'SEVE TROPHY'	As far as judgments of Spanish courts are concerned, the Community trade mark system is an autonomous system, consisting of a set of rules and objectives that are specific, and applied independently of any national system (para. 79).

Since such decisions may serve to indicate reputation and to record successful enforcement of the mark, their relevance should be addressed and examined. Relevance should be given to the type of proceedings involved, to whether the issue was in fact reputation within the sense of Article 8(5) CTMR, to the level of the court, as well as to the number of such decisions.

Case No	Comment
C-100/11 P 'BOTOCYL'	Decisions of the UK national office related to the reputation of 'BOTOX' are facts that may, if relevant, be taken into account by the General Court, despite the CTM owners not being parties in those decisions (para. 78).

There might be differences between the substantive and procedural conditions applicable in national proceedings and those applied in opposition proceedings before the Office. Firstly, there may be differences as to how the requirement of reputation is defined or interpreted. Secondly, the weight the Office gives to the evidence is not necessarily the same as the weight given to it in national proceedings. Furthermore, national instances may be able to take into account *ex officio* facts known to them directly, whereas the Office may not, pursuant to Article 76 CTMR.

For these reasons, the probative value of national decisions will be considerably enhanced if the conditions of law and facts on the basis of which they were taken are made abundantly clear. This is because, in the absence of these elements, it will be more difficult both for the applicant to exercise its right of defence and for the Office to assess the decision's relevance with a reasonable degree of certainty. Similarly, if the decision is not yet final, or if it is outdated due to the time that has elapsed between the two cases, its probative value will be diminished accordingly.

Consequently, the probative value of national decisions should be assessed on the basis of their contents and it may vary depending on the case.

Decisions of the Office

The opponent may also refer to earlier decisions of the Office, on condition that such a reference is clear and unambiguous, and that the language of the proceedings is the same. Otherwise, the opponent must also file a translation of the decision within the four-month period to file further facts, evidence and arguments, in order to allow the applicant to exercise its right of defence.

As regards the relevance and probative value of previous Office decisions, the same rules as for national decisions apply. Even where the reference is admissible and the decision is relevant, the Office is not bound to come to the same conclusion and must examine each case on its own merits.

It follows that previous Office decisions only have a relative probative value and should be evaluated in conjunction with the rest of the evidence, especially where the reference of the opponent does not extend to the materials filed in the first case, that is, where the applicant has not had a chance to comment on them, or where the time that has elapsed between the two cases is quite long.

Case No	Comment
R 0141/2011-1 'GUSSACI GUSSACI GUSSACI GUSSACI' (fig.)	The finding of reputation is confirmed by the previous decision of the Boards of Appeal , according to which 'GUCCI' was considered to be one of the world's leading brands in the field of luxury goods, and reputation of the mark 'GUCCI' as well as the letter 'G', in its various configuration as an abbreviation for 'GUCCI', was found. In particular, reputation was found for the following goods: <i>watches and jewellery</i> (decision of 14/042011, R 143/2010-1, 'GUDDY / GUCCI'), <i>clothing, handbags, leather goods, luggage, shoes, gift, jewellery, fragrance and eyewear</i> (decision of 11/02/2010, R 1281/2008-1 'G' (fig.) / 'G' (fig.) et al.), <i>clothing, handbags, leather goods, luggage and shoes</i> (decision of 17/03/2011, R 543/2010-1, 'G' (fig.) / 'G' (fig.) et al.) (para. 18).

Opinion polls and market surveys

Opinion polls and market surveys are the most suitable means of evidence for providing information about the degree of knowledge of the mark, the market share it has, or the position it occupies in the market in relation to competitors' goods.

The probative value of opinion polls and market surveys is determined by the status and degree of independence of the entity conducting it, by the relevance and the accuracy of the information it provides, and by the reliability of the applied method.

More particularly, in evaluating the credibility of an opinion poll or market survey, the Office needs to know the following.

1. Whether or not it has been conducted by an independent and recognised research institute or company, in order to determine the reliability of the source of the evidence.
2. The number and profile (sex, age, occupation and background) of the interviewees, in order to evaluate whether the results of the survey are representative of the different kinds of potential consumers of the goods in question. In principle, samples of 1 000 – 2 000 interviewees are considered sufficient, provided they are representative of the type of consumer concerned.
3. The method and circumstances under which the survey was carried out and the complete list of questions included in the questionnaire. It is also important to know how and in what order the questions were formulated, in order to ascertain whether the respondents were confronted with leading questions.
4. Whether the percentage reflected in the survey corresponds to the total amount of persons questioned or only to those who actually replied.

Unless the above indications are present, the results of a market survey or opinion poll should not be considered of high probative value, and will not in principle be sufficient on their own to support a finding of reputation.

Case No	Comment
R 0925/2010-2 '1 CLEAN! 2 FRESH! 3 STRONG!' (fig.)	The cancellation applicant did not submit sufficient proof of the reputation of its trade marks. According to the extracts from the 2001 survey conducted in Italy, although the level of 'prompted recognition' stands at 86 %, the rate of 'spontaneous recognition' is only 56 %. Moreover, no indication is given of the questions put to the people surveyed, making it impossible to determine whether the questions were really open and unassisted. The survey further fails to state for which goods the trade mark is known (para. 27).

Likewise, if the above indications are given, but the reliability of source and method are questionable or the statistical sample is too small, or the questions were leading, the credibility of the evidence will be diminished accordingly.

Case No	Comment
R 1191/2010-4 'MÁS KOLOMBIANA ...Y QUÉ MÁS!! (fig.)'	The survey submitted by the opponent does not provide conclusive information to demonstrate that the earlier sign is well-known to the Spanish public for <i>aerated waters</i> as the interviewees were carefully selected on the basis of their origin, that is, Colombians resident in Spain. This is only a very small part of the population living in Spain. The sales figures, publicity investment and presence in publications directed at the immigrant public, contained in the statement before a notary public, are likewise in insufficient amounts for a finding that the earlier sign is well-known. Moreover, the statements are not corroborated by conclusive data on the extent or turnover of the goods (para. 23).
R 1345/2010-1 'Fukato Fukato (fig.)'	In support of its claim under Article 8(5) CTMR, the opponent relies exclusively on an opinion poll that was carried out in 2007. That opinion poll was conducted by an independent company. In principle, samples of 1 000–2 000 interviewees are considered sufficient, provided they are representative of the type of consumer concerned. The opponent's opinion poll was based on a sample of 500 interviewees, which is not sufficient in respect of the services for which reputation is claimed. According to the opinion poll, the logo of the earlier mark has been associated especially with services in the financial and insurance fields. Since the opposition is only based on Class 42 with regard to the earlier Community trade mark, it does not cover financial and insurance services. Consequently, the submitted opinion poll is not suitable proof of the reputation of the opponent's Community trade mark (para. 58).

Conversely, opinion polls and market surveys that fulfil the above requirements (independence and trustworthiness of source, reasonably large and widespread sample and reliable method) will be a strong indication of reputation, especially if they show a high degree of trade mark awareness.

Audits and inspections

Audits and inspections of the opponent's undertaking may provide useful information about the intensity of use of the mark, as they usually comprise data on financial results, sales volumes, turnovers, profits etc. However, such evidence will be pertinent only if it specifically refers to the goods sold under the mark in question, rather than to the opponent's activities in general.

Audits and inspections may be carried out on the initiative of the opponent itself, or may be required by company law and/or financial regulations. In the former case, the same rules as for opinion polls and market surveys apply, that is, the status of the entity conducting the audit and the reliability of the applied method will be of essence for determining its credibility, whereas the probative value of official audits and inspections will be as a rule much higher, since they are usually conducted by a state authority or by a recognised body of auditors, on the basis of generally accepted standards and rules.

Certifications and awards

This kind of evidence includes certifications and awards by public authorities or official institutions, such as chambers of commerce and industry, professional associations and societies, consumer organisations etc.

The reliability of certifications by authorities is generally high, as they emanate from independent and specialised sources, which attest facts in the course of their official tasks. For example, the average circulation figures for periodicals issued by the competent press-distribution associations are conclusive evidence about the performance of a mark in the sector.

Case No	Comment
R 0907/2009-2 'O2PLS'	The many brand awards won by the mark were considered an important part of the evidence to show reputation together with the huge advertising investments and the number of articles published in different publications (para. 9(iii) and para. 27).

The same applies to quality certifications and awards granted by such authorities, as the opponent usually has to meet objective standards in order to receive the award. Conversely, prizes and awards offered by unknown entities, or on the basis of unspecified or subjective criteria, should be given very little weight.

The relevance of a certification or award to the specific case largely depends on its contents. For example, the fact that the opponent is a holder of an ISO 9001 quality certificate, or of a royal warrant, does not automatically mean that the sign is known to the public. It only means that the opponent's goods meet certain quality or technical standards or that it is a supplier of a royal house. However, if such evidence is coupled with other indications of quality and market success, it may lead to the conclusion that the earlier mark has a reputation.

Articles in the press or in specialised publications

The probative value of press articles and other publications concerning the opponent's mark mainly depends on whether such publications are covert promotional matter, or if, on the contrary, they are the result of independent and objective research.

Case No	Comment
Joined cases T-345/08 and T-357/08 'BOTOXYL', confirmed by C-100/11 P	The very existence of articles in a scientific publication or the general-interest press constitutes a relevant factor in establishing the reputation of the products marketed under the trade mark BOTOX with the general public, irrespective of the positive or negative content of those articles (para. 54).

Case No	Comment
R 0555/2009-2 'BACI MILANO' (fig.)	The reputation of the earlier trade mark in Italy was proven by the copious amount of documentation submitted by the opponent, which included, inter alia, an article from <i>Economy</i> revealing that in 2005 the 'BACI & ABBRACCI' trade mark was one of the fifteen most counterfeited fashion brands in the world; an article published in <i>Il Tempo</i> on 05/08/2005, in which the 'BACI & ABBRACCI' trade mark is mentioned alongside others, including Dolce & Gabbana, Armani, Lacoste and Puma, as being targeted by counterfeiters; an article published in <i>Fashion</i> on 15/06/2006, in which the trade mark is defined as 'a true market phenomenon'; publicity campaigns from 2004 to 2007, with testimonials from entertainment and sports celebrities; a market survey conducted by the renowned independent agency Doxa in September 2007, from which it emerges that the trade mark is at the top of mind in the fashion sector for 0.6% of the Italian public (para. 35).

Hence, if such articles appear in publications of a high status or are written by independent professionals, they will have a quite high value, as for example when the success of a specific brand becomes the object of a case study in specialised journals or in scientific publications. The presence of a mark in a dictionary (which is not a press article but is still a publication) is a means of evidence with high value.

Case No	Comment
Joined cases T-345/08 and T-357/08 'BOTOXYL', confirmed by C-100/11 P	The inclusion of a word in a dictionary is the expression of a fair amount of recognition on the part of the public. The references in the 2002 and 2003 editions of a number of dictionaries published in the United Kingdom constitute one of the items of evidence which may establish the reputation of the trade mark BOTOX in that country or amongst the English-speaking public of the European Union. (paras 55, 56).

Annual reports on economic results and company profiles

This type of evidence includes all kinds of internal publications giving varied information about the history, activities and perspectives of the opponent's company, or more detailed figures about turnovers, sales, advertising etc.

To the extent that such evidence derives from the opponent and is mainly intended to promote its image, its probative value will mostly depend on its contents and the relevant information should be treated with caution, especially if it mainly consists of estimates and subjective evaluations.

However, where such publications are circulated to clients and other interested circles and contain objectively verifiable information and data, which may have been compiled or revised by independent auditors (as is often the case with annual reports), their probative value will be substantially enhanced.

Invoices and other commercial documents

All kinds of commercial documents may be grouped under this heading, such as invoices, order forms, distribution and sponsoring contracts, samples of

correspondence with clients, suppliers or associates etc. Documents of this sort may provide a great variety of information as to the intensity of use, the geographical extent and duration of the use of the mark.

Even though the relevance and credibility of commercial documents is not disputed, it will be generally difficult to prove reputation on the basis of such materials alone, given the variety of factors involved and the volume of documents required. Furthermore, evidence such as distribution or sponsoring contracts and commercial correspondence are more appropriate for giving indications about the geographical extent or the promotional side of the opponent's activities, than for measuring the success of the mark in the market and thus may only serve as indirect indications of reputation.

Case No	Comment
R 1272/2010-1 'GRUPO BIMBO' (fig.) (T-357/11)	The evidence submitted shows a high level of recognition of the mark on the Spanish market. The total invoices on the Spanish tin-loaf market in 2004 amounted to EUR 346.7 million, of which the opponent's invoices amounted to EUR 204.9 million. The submitted invoices cover advertisements on TV, as well as in newspapers and magazines. Therefore, the reputation of 'BIMBO' in Spain for <i>industrially produced bread</i> has been substantiated (para. 64). The Court did not address this point.

Advertising and promotional material

This kind of evidence may take various forms, such as press cuttings, advertising spots, promotional articles, offers, brochures, catalogues, leaflets etc. In general, such evidence cannot be conclusive of reputation on its own, due to the fact that it cannot give much information about actual trade mark awareness.

However, some conclusions about the degree of exposure of the public to advertising messages concerning the mark may be drawn by reference to the kind of the medium used (national, regional, local) and to the audience rates or circulation figures attained by the relevant spots or publications, if of course this kind of information is available.

Case No	Comment
R 0043/2010-4 'FFR' (fig.) (T-143/11)	The documents submitted show that the device of a black rooster has acquired reputation and will be associated with wines from the Chianti Classico-region. The opponent provided several copies of advertisements in newspapers and magazines showing its promotional activity as well as independent articles displaying a black rooster in connection with the Chianti Classico region. However, given that the reputation only pertains to the device of a black rooster and given that this device is only one part of the earlier marks, serious doubts arise about whether reputation can be attributed to the marks as a whole. Moreover, for the same reason, doubt also arises about which marks the reputation could be attributed to, given that the opponent owns several marks. (paras 26, 27). The Court did not assess the evidence on reputation.

In addition, such evidence may give useful indications of the kind of goods covered, the form in which the mark is actually used and the kind of image the opponent is trying to create for its brand. For example, if the evidence shows that the earlier registration for

which reputation is claimed covers a device, but in reality this device is used combined with a verbal element, it would not be consistent to accept that the device by itself has a reputation.

Case No	Comment
R 1308/2010-4 'WM GRAND PRIX'	In all the examples of actual use on the podia, media kits, posters, race cards, letter head, programme covers, tickets, passes etc., submitted by the opponent, the words GRAND PRIX are always used in combination with other elements. No evidence of use was submitted of the use of the trade mark GRAND PRIX in an independent way (paras 53, 54).
T-10/09, 'F1-LIVE' (C-196/11 P)	The evidence of reputation makes reference to the earlier figurative mark 'F1 Formula 1' and not to the earlier word marks. Without its particular logotype the text 'Formula 1' and its abbreviation 'F1' are perceived as descriptive elements for a category of racing cars or races involving those cars. The reputation was not proven for the word marks which are not identical or similar (paras 53, 54, 67). The Court did not address this point.

3.2 The similarity of the signs

A 'certain degree of similarity between the signs' must be found for an opposition under Article 8(5) CTMR to succeed (judgment of 24/03/2011, C-552/09 P, 'TiMi KINDERJOGHURT', para.53). If the signs are found **dissimilar** overall, the examination aimed at establishing whether the other requirements under Article 8(5) CTMR are met **should not be carried out**, as the opposition cannot succeed.

A subject of some uncertainty is the relationship between 'similarity' within the meaning of Article 8(5) CTMR and the meaning of the same term used in Article 8(1)(b) CTMR. According to the clear wording of these two provisions, **a similarity (or identity) between the signs is a precondition for the application of both Article 8(1)(b) and Article 8(5) CTMR.** The use of the same term in both provisions is an argument in favour of the need to interpret this term in the same way and the case-law has confirmed this.

Accordingly, the assessment of similarity should be made according to the **same criteria** that apply in the context of Article 8(1)(b) CTMR, thus taking into account elements of **visual, aural or conceptual similarity** (judgment of 23/10/2003, C-408/01, 'Adidas', para. 28, relating to the interpretation of Article 5(2) TMD, and judgment of 24/03/2011, C-552/09P, 'TiMi KINDERJOGHURT', para. 52). See the Guidelines, Part C, Opposition, Section 2, Identity and Likelihood of Confusion, Chapter 3, Comparison of Signs.

The general rules for assessing the signs established for the examination of this criterion under Article 8(1)(b) CTMR apply, such as the rule that consumers perceive the sign as a whole and only rarely have the chance to make a direct comparison between the different marks and must place their trust in the imperfect image of them that they have kept in mind (judgment of 25/01/2012, T-332/10 'Viaguara', paras 33, 34) (see the Guidelines, Part C, Opposition, Section 2, Identity and Likelihood of Confusion, Chapter 8, Global Assessment, paragraph 4, Imperfect recollection).

3.2.1 Notion of ‘similarity’ pursuant to Article 8(5) CTMR compared with Article 8(1)(b) CTMR

Despite application of the same criteria for similarity of the signs in Article 8(1)(b) and Article 8(5) CTMR, the purposes underlying these Articles are different: for Article 8(1)(b) CTMR, the aim is to prevent the registration of a later trade mark that, if used, could confuse the relevant public as regards the commercial origin of the goods or services concerned, whereas for Article 8(5) CTMR, the aim is to prevent the registration of a later trade mark that, if used, could take unfair advantage of, or be detrimental to, the reputation or distinctiveness of the earlier reputed trade mark.

The relationship between the notion of ‘similarity’ under the two provisions was addressed by the Court in *TiMi KINDERJOGHURT*: ‘It should be noted at the outset that ... the existence of a similarity between the earlier mark and the challenged mark is a precondition for the application both of Article 8(1)(b) [CTMR] and of Article 8(5) [CTMR]’ (para. 51).

In the context both of Article 8(1)(b) and of Article 8(5) CTMR, a finding of similarity between the marks in question requires the existence, in particular, of elements of visual, aural or conceptual similarity (judgment of 23/10/2003, C-408/01 ‘Adidas-Salomon and Adidas Benelux’, para. 28).

However, those provisions differ in terms of the degree of similarity required. Whereas the protection provided for under Article 8(1)(b) CTMR is conditional upon a finding of a degree of similarity between the marks at issue such that there is a likelihood of confusion between them on the part of the relevant section of the public, the existence of such a likelihood is not necessary for the protection conferred by Article 8(5) CTMR. Accordingly, the types of injury referred to in Article 8(5) CTMR may result from a lesser degree of similarity between the marks in question, provided that it is sufficient for the relevant section of the public to make a connection between those marks that is to say, to establish a link between them (judgment of 23/10/2003, C-408/01 ‘Adidas-Salomon and Adidas Benelux’, paras 27, 29, 31, and judgment of 27/11/2008, C-252/07 ‘Intel Corporation’, paras 57, 58, 66).

Nevertheless, it is not apparent either from the wording of those provisions or from the case-law that the similarity between the marks at issue must be assessed in a different way, depending on whether the assessment is carried out under Article 8(1)(b) CTMR or under Article 8(5) CTMR.

To sum up, the application of both Article 8(1)(b) and Article 8(5) CTMR requires a finding of similarity between the signs. Consequently, if in the examination of Article 8(1)(b) CTMR the signs were found to be **dissimilar**, the opposition will necessarily fail under Article 8(5) CTMR too.

However, once the signs have been found to be **similar**, depending on whether Article 8(1)(b) or Article 8(5) CTMR are involved, the examiner will independently assess whether the degree of similarity is sufficient for the relevant provision to apply (and in correlation with the further relevant factors).

Therefore, a degree of similarity between the marks that, after an overall assessment of the factors, led to a partial finding of likelihood of confusion under Article 8(1)(b) CTMR does not **necessarily** trigger a link between the signs under Article 8(5) CTMR, for example because the markets concerned are completely distinct. A full analysis

must take place. This is because **the similarity of the signs is only one of the factors to be considered when assessing whether there is such a link** (see the relevant criteria listed under paragraph 3.3 below on the 'link').

Depending on the case, the following scenarios are possible.

- Article 8(1)(b) CTMR fails because the signs are *dissimilar* – Article 8(5) CTMR fails too, since the same conclusion applies.
- Likelihood of confusion pursuant to Article 8(1)(b) CTMR is excluded (e.g. because the goods or services are dissimilar or very remotely similar), but the signs are similar – the examination of Article 8(5) CTMR must be carried out (see T-143/11 'CHIANTI CLASSICO' paras 66-71).
- The similarity of the signs together with the other relevant factors justifies the *exclusion* of likelihood of confusion pursuant to Article 8(1)(b) CTMR, but the similarity between the signs might be sufficient to establish a *link* between them under Article 8(5) CTMR, in view of the other relevant factors to be taken into account.

3.3 The link between the signs

The Court has made it clear that in order to assess whether the use of the contested mark would be likely to cause detriment to, or take unfair advantage of, the distinctive character or repute of the earlier mark, it is **necessary to establish** – once the signs have been found to be similar – **if, given all the relevant factors, a link (or association) between the signs will be established in the mind of the relevant public**. The subsequent case-law has made it clear that such an analysis should precede the final assessment of the existence of a risk of injury.

The notion of a link between the signs was addressed by the Court in its judgment of 27/11/2008, C-252/07 'Intel Corporation', para. 30 (and the case-law cited therein), which, although referring to the interpretation of Article 4(4)(a) TMD, is applicable to Article 8(5) CTMR which is the equivalent provision in the CTMR. In *Intel*, the Court, stated the following (para. 30):

The types of injury referred to in Article 4(4)(a) of the Directive, where they occur, are the consequence of a certain degree of similarity between the earlier and later marks, by virtue of which the relevant section of the public makes a connection between those two marks, that is to say, establishes a link between them even though it does not confuse them (see, in relation to Article 5(2) of the Directive, *General Motors*, para. 23; *Adidas-Salomon and Adidas Benelux*, para. 29, and *adidas and adidas Benelux*, para. 41).

The term '**link**' is often also referred to as '**association**' in other paragraphs of this part of the Guidelines as well as in case-law. These **terms** are, at times, **used interchangeably**.

The Court made it clear that the mere fact that the marks in question are similar **is not sufficient** for it to be concluded that there is a link between them. Rather, **whether or not there is a link between the marks at issue must be appreciated globally**, taking into account all factors relevant to the circumstances of the case.

According to *Intel*, (para. 42), the following may be **relevant factors** when assessing whether such a link exists.

- The degree of similarity between the conflicting marks. The more similar they are, the more likely it is that the later mark will bring the earlier mark with a reputation to the mind of the relevant public (judgment of 06/07/2012, T-60/10, 'ROYAL SHAKESPEARE', para. 26 and, by analogy, preliminary ruling of 27/11/2008, C-252/07, *Intel*, para. 44).
- The nature of the goods or services for which the earlier mark is reputed and the later mark seeks registration, including the degree of similarity or dissimilarity between those goods or services, and the relevant section of the public. The goods or services may be so dissimilar that the later mark is unlikely to bring the earlier mark to the mind of the relevant public (*Intel*, para. 49).
- The strength of the earlier mark's reputation.
- The degree of the earlier mark's distinctive character, whether inherent or acquired through use. The more inherently distinctive the prior mark, the more likely it will be brought to a consumer's mind when encountering a similar (or identical) later mark.
- The existence of likelihood of confusion on the part of the public.

This list is not exhaustive. A link between the marks at issue may be established or excluded on the basis of only some of those criteria.

The question of whether the relevant public will establish a link between the marks at issue is a **question of fact** which must be answered in the light of the facts and circumstances of each individual case.

The assessment of whether a 'link' will be established must take into account all the relevant factors that will then need to be balanced. Therefore, even a faint or remote degree of similarity between the signs (which might not be sufficient for a finding of likelihood of confusion under Article 8(1)(b) CTMR) still justifies assessing all the relevant factors to determine if it is likely that a link between the signs will be established in the mind of the relevant public. In this respect, in its judgment of 24/03/2011, C-552/09 P, 'TiMi Kinderjoghurt', paras 65, 66, the Court stated the following:

Although that global assessment implies some interdependence between the relevant factors, and a low degree of similarity between the marks may therefore be offset by the strong distinctive character of the earlier mark ... the fact remains that where there is no similarity between the earlier mark and the challenged mark, the reputation or recognition enjoyed by the earlier mark and the fact that the goods or services respectively covered are identical or similar are not sufficient for it to be found that the relevant public makes a link between them ...

... It is only if there is some similarity, even faint, between the marks at issue that the General Court must carry out a global assessment in order to ascertain whether, notwithstanding the low degree of similarity between

them, there is, on account of the presence of other relevant factors such as the reputation or recognition enjoyed by the earlier mark, a likelihood of confusion or a link made between those marks by the relevant public.

Case-law has made it clear that a link is not sufficient, in itself, to establish that there may be one of the forms of damage referred to in Article 8(5) CTMR (judgment of 26/09/ 2012, T-301/09, 'Citigate', para. 96, and the case-law cited therein). However, as will be explained in detail under paragraph 3.4 'The risk of injury' below, the existence of the link (or association) between the signs is necessary before determining whether detriment or unfair advantage are likely.

3.3.1 Examples where a link was found between the signs

The following are examples where it was found that the degree of similarity between the signs (together with further factors) was sufficient to conclude that consumers would establish a link between them.

Earlier reputed sign	CTM application	Case No
BOTOX	BOTOLYST and BOTOCYL	Joined Cases T-345/08 and T-357/08 confirmed in C-100/11P)
<p>The trade mark BOTOX had a reputation for <i>pharmaceutical preparations for the treatment of wrinkles</i> in the United Kingdom on the filing date of the contested marks, which cover a range of goods in Class 3. The General Court confirmed the Board's finding that there is a certain overlap between the goods, namely a low degree of similarity between the opponent's <i>pharmaceutical preparations for the treatment of wrinkles</i> and the contested <i>cosmetics among other creams</i>, whereas the remaining contested goods, namely <i>perfumes, sun-tanning milks, shampoos, bath salts, etc.</i>, are dissimilar. Nevertheless, the goods at issue concern related market sectors. The General Court confirmed the Board's finding that the relevant public – practitioners as well as the general public – would not fail to notice that both the applied for trade marks, BOTOLIST and BOTOCYL, begin with 'BOTO-', which comprises almost the whole of the mark BOTOX, which is well known to the public. The General Court pointed out that 'BOTO-' is not a common prefix, either in the pharmaceutical field or in the cosmetic field and that it has no descriptive meaning. Even if the sign BOTOX could be broken down into 'bo' for 'botulinum' and 'tox' for 'toxin' in reference to the active ingredient which it uses, that word would then have to be considered to have acquired a distinctive character, inherent or through use, at least in the United Kingdom. In light of all the relevant factors, the public would naturally be led to establish a link between the marks BOTOLIST and BOTOCYL and the reputed mark BOTOX (paras 65-79).</p>		



Earlier reputed sign	CTM application	Case No
RED BULL		R 0070/2009-1
<p>The Board found that a link would be established between RED DOG and RED BULL because (i) the marks have some relevant common features, (ii) the conflicting goods in Classes 32-33 are identical, (3) the RED BULL mark is reputed, (iv) the RED BULL mark has acquired a strong distinctive character through use and (v) there might be a possibility of confusion (para 19). It is reasonable to assume that the average consumer of beverages, who knows the reputed RED BULL mark and sees the RED DOG marks on the same kind of beverages would immediately recall the earlier mark. According to the <i>Intel</i> judgement, this is 'tantamount to the existence of a link' between the marks (para 24).</p>		



Earlier reputed sign	CTM application	Case No
VIAGRA	VIAGUARA	T-332/10
<p>The trade marks are highly similar overall (para. 42). Visually, all the letters of the earlier trade mark are present in the contested one, the first four and the final two are in the same sequence. There is a visual similarity, especially since the public tends to pay more attention to the beginnings of words (para 35, 36). The identity of the first and the last syllable, together with the fact that the middle syllables have in common the sound [g], leads to a high degree of phonetic similarity (paras 38, 39). Neither of the signs has a meaning and, therefore, the public will not differentiate them conceptually (para. 40).</p> <p>The earlier mark covers <i>pharmaceuticals for the treatment of erectile dysfunctions</i> in Class 5, whereas the contested mark covers <i>non-alcoholic and alcoholic drinks</i> in Classes 32 and 33. The reputation of the earlier sign for the mentioned goods is not disputed. The General Court found that although no direct connection can be established between the goods covered by the marks in dispute since they are dissimilar, an association with the earlier mark remains possible, taking into account the high degree of similarity between the signs and the strong reputation acquired by the earlier mark. Therefore, the General Court concludes that a link is likely to be established between the marks (para. 52).</p>		

Earlier reputed sign	CTM application	Case No
RSC-ROYAL SHAKESPEARE COMPANY	ROYAL SHAKESPEARE	T-60/10
<p>As the contested trade mark is exclusively made up of the central and distinctive element of the earlier trade mark, namely the expression 'royal shakespeare', the signs at issue are visually, phonetically and conceptually similar. Therefore, the average consumer will establish a link between those signs (para 29). The earlier mark covers services in Class 41, including <i>theatre productions</i>, whereas the contested mark covers <i>non-alcoholic and alcoholic drinks</i> in Classes 32 and 33 and <i>providing of food and drink, restaurants, bars, pubs, hotels; temporary accommodation</i> in Class 42. The General Court confirmed the Board's finding of the 'exceptional' reputation of the earlier mark in the United Kingdom for theatre productions. The relevant public for the contested trade mark is the same as the relevant public for the earlier trade mark, namely the public at large (para 58). Although the contested goods in Classes 32-33 do not appear to be directly and immediately linked to the opponent's theatre productions, there is a certain proximity and link between them. The General Court refers to the judgment of 04/11/2008, T-161/07 'Ugly (COYOTE UGLY)', paras 31-37, where a certain similarity between <i>entertainment services</i> and <i>beer</i> was found due to their complementarity. The General Court added that it is common practice, in theatres, for bar and catering services to be offered either alongside and in the interval of a performance. Moreover, irrespective of the above, in view of the established reputation of the earlier trade mark, the relevant public, namely the public at large in the United Kingdom, would be able to make a link with the intervener when seeing a beer with the contested trade mark in a supermarket or in a bar (para. 60).</p>		

3.3.2 Examples where no link was found between the signs

The following are examples where an overall assessment of all of the relevant factors showed that it was unlikely that a link would be established between the signs.

Earlier reputed sign	CTM application	Case No
		R 0724/2009-4
<p>The signs only have a certain degree of visual and aural similarity. The Board confirms that the reputation of the earlier marks has been proven solely for <i>distribution of energy services</i>. These services are completely different from the goods for which protection is requested in Classes 18, 20, 24 and 27. The relevant section of the public is the same, given that the services for which a reputation has been proven, namely <i>distribution of energy services</i>, are aimed at the general public and the goods in dispute are also aimed at the average consumer who is reasonably observant and circumspect. However, even if the relevant section of the public for the goods or services for which the conflicting marks are registered is the same or overlaps to some extent, those goods or services may be so dissimilar that the later mark is unlikely to bring the earlier mark to the mind of the relevant public. The huge differences in usage between the goods in dispute and the services for which a reputation has been proven make it very unlikely that the public will make a link between the signs in dispute, which is essential for the application of Article 8(5) CTMR and for unfair advantage to be taken of the distinctive character or repute of the earlier mark. It is even less likely that, when intending to purchase a bag or item of furniture, the relevant public will link these goods to a trade mark that is very well known, but for services in the energy sector (paras 69-79).</p>		

Earlier reputed sign	CTM application	Case No
G-STAR and 		T-309/08
<p>Visually the signs cause a different overall impression, due to the figurative element of a Chinese dragon's head placed at the beginning of the mark applied for. Aurally, there is a rather close aural similarity between the marks at issue. The signs are conceptually different, since the element 'star' of the earlier marks is a word which is part of basic English vocabulary, the meaning of which is widely understood throughout the Community. Therefore, the earlier marks will be perceived as referring to a star or a famous person. It is possible that a part of the relevant public will attribute to the element 'stor' of the contested mark the sense of the Danish and Swedish word 'stor', meaning 'big, large', or will regard it as a reference to the English word 'store' meaning 'shop, storage'. It is, however, more likely that the majority of the relevant public will not attribute any particular meaning to that element. Therefore, the relevant public will perceive the marks at issue as conceptually different inasmuch as the earlier marks have a clear meaning throughout the Community, while the mark applied for has either a different meaning for part of the relevant public or has no meaning. According to settled case-law, where the meaning of at least one of the two signs at issue is clear and specific so that it can be grasped immediately by the relevant public, the conceptual differences between those signs may counteract the visual and aural similarities between them. The Board of Appeal was right to find that the visual and conceptual differences between the marks prevented any assumption of a possible link between them (paras 25-36).</p>		

Earlier reputed sign	CTM application	Case No
ONLY		R 1556/2009-2 (confirmed by T-586/10)
<p>The goods in Class 3 are identical and target the same public. There is a slight degree of visual and conceptual similarity between the signs at issue and a moderate degree of aural similarity. Even if the earlier marks had a reputation, the differences between the signs, in particular due to the conceptual unit created by the combination of the element 'only' and the distinctive dominant element 'givenchy', would be significant enough for the public not to make any connection between them. Therefore, the Board of Appeal was correct in finding that one of the conditions for applying Article 8(5) CTMR, namely that the signs be sufficiently similar to lead the relevant public to make a connection between them, has not been met (paras 65, 66).</p>		

Earlier reputed sign	CTM application	Case No
KARUNA		R 696/2009-4 (confirmed by T-357/10)
<p>The goods concerned, <i>chocolate</i> in Class 30, are identical. The signs differ visually not only because of the figurative elements in the sign applied for, but also because of their verbal elements. Even though the verbal elements of the marks at issue have three letters out of six in common, a difference arises because the earlier marks begin with the letters 'ka' while the mark applied for begins with the letters 'co' and because the consumer normally attaches more importance to the first part of words. There is a low degree of phonetic similarity between the signs taken as a whole. Conceptually, the word 'corona', meaning 'crown' in Spanish, does not have any meaning in Estonian, Latvian or Lithuanian. Accordingly, no conceptual comparison is possible between the signs at issue in the three Baltic States. The mere fact that the Lithuanian word 'karūna' means 'crown' is not sufficient to establish that the relevant public associates the terms 'karuna' or 'karūna' with the word 'corona', which remains a foreign word. To conclude, the General Court reiterated that if the condition of similarity of the signs is not met under Article 8(1)(b) CTMR, it must also be held, on the basis of the same analysis, that that condition is not met under Article 8(5) CTMR either (paras 30-34 and 49).</p>		

3.4 The risk of injury²

3.4.1 Protected subject matter

Article 8(5) CTMR does **not protect the reputation** of the earlier mark **as such**, in the sense that it does **not intend to prevent the registration of all marks identical with or similar to a mark with reputation**. In addition, there must be a likelihood that use of the contested application without due cause would take unfair advantage of, or would be detrimental to, the distinctive character or the repute of the earlier mark. The Court confirmed this by stating that 'once the condition as to the existence of reputation is fulfilled, the examination has to proceed with the **condition that the earlier mark must be detrimentally affected** without due cause' (see judgment of 14/09/1999, C-375/97, 'General Motors', para. 30).

The Court did not set out in more detail exactly what would count as detriment or unfair advantage, even though it stated in *Sabel* that Article 8(5) CTMR '[does] not require

² For the purposes of these Guidelines, the term 'injury' covers taking 'unfair advantage' even though in such cases there is not necessarily an 'injury' in the sense of detriment either to the distinctive character or repute of the mark or, more generally, to its proprietor.

proof of likelihood of confusion', thereby stating the obvious, namely that the enlarged protection granted to reputed marks is not concerned with their function of origin (see judgment of 11/11/1997, C-251/95, 'Sabel', para. 20).

However, in a series of previous decisions the Court stated that apart from indicating origin, a trade mark may also fulfil other functions worthy of protection. More particularly, it confirmed that a trade mark can offer a guarantee that all the goods coming from a single undertaking have the same quality (**guarantee function**) and that it can serve as an advertising instrument by reflecting back the goodwill and prestige it has acquired in the market (**advertising function**) (judgment of 17/10/1990, C-10/89 CNL-SUCAL v HAG, judgment of 11/07/1993, joined cases C-427/93, C-429/93 and C-436/93, 'Bristol-Myers Squibb and Others v Paranova', judgment of 11/11/1997, C-349/95, 'Loendersloot v Ballantine & Son and Others', judgment of 04/11/1997, C-337/95, 'Parfums Christian Dior v Evora', and judgment of 23/02/1999, C-63/97, 'BMW').

It follows that trade marks do not only serve to indicate the origin of a product, but also to convey a certain **message or image** to the consumer, which is **incorporated in the sign** mostly through use and, once acquired, forms part of its distinctiveness and repute. In most cases of reputation these features of the trade mark will be particularly developed, as the commercial success of a brand is usually based on product quality, successful promotion, or both and, for this reason, they will be especially valuable to the trade mark owner. This **added value** of a mark with reputation is precisely what Article 8(5) CTMR intends to protect against undue detriment or unfair advantage.

Hence, the protection under Article 8(5) CTMR extends to all cases where the use of the contested trade mark applied for is likely to have an adverse effect on the earlier mark, in the sense that it would diminish its attractiveness (detriment to distinctiveness) or devalue the image it has acquired among the public (detriment to repute), or the use of the contested mark is likely to result in misappropriation of its powers of attraction or exploitation of its image and prestige (unfair advantage of the distinctive character or repute).

Given also that a **very strong reputation** is both easier to harm and more tempting to take advantage of, owing to its great value, the Court underlined that 'the stronger the earlier mark's distinctive character and reputation, the easier it will be to accept that detriment has been caused to it' (judgment of 27/11/2008, C-252/07 'Intel', paras 67, 74, judgment of 25/05/2005, T-67/04, 'Spa-finders', para. 41). Even though the Court did not say so expressly, the same must be accepted as regards the unfair advantage that the applicant might enjoy at the expense of the earlier mark.

3.4.2 Assessment of the risk of injury

In *General Motors* the Court did not deal with the assessment of detriment and unfair advantage in great detail, as this issue was not part of the question referred to it. It only stated that it 'is only where there is a sufficient degree of knowledge of that mark that the public, when confronted by the later trade mark, may possibly make an **association between the two trade marks ... and that the earlier trade mark may consequently be damaged**' (judgment of 14/09/1999, C-375/97, 'General Motors', para. 23).

Even though this statement is too limited to serve as a basis for a comprehensive analysis of the existence of a risk of injury, it gives at least a significant indication, namely that detriment or unfair advantage must be the **consequence of an association** between the conflicting marks in the minds of the public, made possible by the similarities between the marks, their distinctiveness, the reputation and other factors (see paragraph 3.3 above).

The need for an association capable of causing detriment has a two-fold consequence for the assessment of detriment or unfair advantage.

- Firstly, if the alleged detriment or unfair advantage is not the result of an association between the marks, but is due to other, extraneous reasons, it is not actionable under Article 8(5) CTMR.
- Secondly, if in view of the overall circumstances of the case, an association between the marks is not likely, the necessary link between the use of the later mark and the detrimental effect will be missing. Therefore, the similarities between the signs and the reputation of the earlier mark must be of such a nature and degree that, considering all factors, the consumer will associate the signs, in the sense that encountering one of them will bring to mind the other.

Furthermore, as the Court observed, an association between the marks requires that the part of the **public which is already familiar with the earlier mark** is also **exposed to the later mark**. This will be easier to establish where the earlier mark is known to the public at large, or where the consumers of the respective goods and services largely overlap. However, in cases where the goods and services are significantly different from each other and such a connection between the respective publics is not obvious, the opponent must justify why the marks will be associated, by reference to some other link between its activities and those of the applicant, for example where the earlier mark is exploited outside its natural market sector, for instance, by licensing or merchandising (see paragraph 3.3 above).

Earlier reputed sign	CTM application	Case No
TWITTER		R 1074/2011-5
Repute for services in Classes 38, 42 and 45, inter alia, a <i>website for social networking</i>	Classes 14, 18 and 25	
<p>The Board defined the relevant public as the average European consumer of the goods applied for, which are ordinary goods meant for the general public.</p> <p>The Board found it likely that the applicant's goods could be seen as merchandising products coming from the opponent. Items such as t-shirts, key chains, watches, hand bags, jewellery, caps etc. are very frequently used as marketing means bearing trade marks which relate to entirely distinct goods and services. Upon encountering the sign TWITTER used on a watch, a scarf or a t-shirt, the relevant consumer would inevitably make a mental connection with the opponent's sign and the services it offers on account of the reputation of the opponent's mark. This would give the applicant a competitive advantage since its goods would benefit from the extra attractiveness they would gain from the association with the opponent's older mark. Buying a TWITTER watch as a present for someone who is known to be a TWITTER user is, for example, an action motivated by the fondness for the earlier mark (para. 40).</p>		

The more immediately and strongly the earlier mark is brought to mind by the later sign, the greater the likelihood that the current or future use of the sign is taking, or will take, unfair advantage of the distinctive character or the repute of the mark or is, or will be, detrimental to it (judgments of 27/11/2008, C-252/07 'Intel', paras 67-69; judgment of 18/06/2009, C-487/07 'L'Oréal', paras 41, 43).

Therefore, the evaluation of detriment or unfair advantage must be based on an overall assessment of all the factors relevant to the case (including in particular the similarity of signs, the reputation of the earlier mark, the respective consumer groups and market sectors), with a view to determining whether the marks may be associated in a way which may adversely affect the earlier trade mark.

3.4.3 Types of injury

Article 8(5) CTMR refers to the following types of injury: 'take unfair advantage of, or be detrimental to, the distinctive character or the repute of the earlier trade mark'. Therefore, Article 8(5) CMTR applies if any of the following **three alternative requirements** is fulfilled, namely if use of the contested mark would:

- take unfair advantage of the distinctiveness, or the repute of the earlier mark;
- cause detriment to the distinctiveness;
- cause detriment to the repute.

As regards the first type of injury, the wording of Article 8(5) CTMR suggests the existence of two kinds of unfair advantage, but settled case-law treats both as a single injury under Article 8(5) CTMR (see, for example, judgment of 06/07/2012, T-60/10, 'RSC-Royal Shakespeare Company', para. 47). For the sake of completeness, both aspects of the same injury will be dealt with under paragraph 3.4.3.1 below.

As demonstrated in the Guidelines, Part C, Opposition, Section 2, Identity and Likelihood of Confusion, likelihood of confusion relates *only* to confusion about the commercial origin of goods and services. Article 8(5) CTMR, in contrast, protects earlier *reputed* marks in cases of association or confusion that does not necessarily relate to the commercial origin of goods/services. Article 8(5) CTMR protects the heightened effort and financial investment that is involved in creating and promoting trade marks to the extent that they become reputed by protecting these marks against later similar marks taking unfair advantage of, or being detrimental to, the distinctive character or the repute of the earlier trade mark. There is a rich lexicon of vocabulary that is used in relation to this area of trade mark law. The most common terms are set out below.

Terms in Article 8(5) CTMR	Commonly used equivalents
Unfair advantage	Free-riding, riding on the coat-tails
Detriment to distinctiveness	Dilution by blurring, dilution, blurring, watering down, debilitating, whittling away
Detriment to repute	Dilution by tarnishing, tarnishment, degradation

3.4.3.1 Taking unfair advantage of distinctiveness or repute

The nature of the injury

The notion of taking **unfair advantage of distinctiveness or repute** covers cases where the applicant benefits from the attractiveness of the earlier right by affixing on its goods/services a sign which is similar (or identical) to one widely known in the market and, thus, misappropriating its attractive powers and advertising value or exploiting its reputation, image and prestige. This may lead to unacceptable situations of commercial parasitism where the applicant is allowed to take a 'free-ride' on the investment of the opponent in promoting and building-up goodwill for its mark, as it may stimulate the sales of the applicant's products to an extent which is disproportionately high in comparison with the size of its promotional investment.

In its judgment of 18/06/2009, C-487/09, 'L'Oréal and others', the Court indicated that unfair advantage exists where there is a transfer of the image of the mark or of the characteristics which it projects to the goods identified by the identical or similar sign. By riding on the coat-tails of the reputed mark, the applicant benefits from its power of attraction, its reputation and its prestige. It also exploits, without paying any financial compensation, the marketing effort expended by the proprietor of the mark in order to create and maintain the image of that mark (paras 41, 49).

Earlier reputed sign	CTM application	Case No
SPA LES THERMES DE SPA	SPA-FINDERS	T-67/04
The concept of taking unfair advantage of the distinctive character or the repute of the earlier mark must be intended to encompass instances where there is clear exploitation and free-riding on the coattails of a famous mark or an attempt to trade upon its reputation (see to that effect Opinion of Advocate General Jacobs in Adidas, point 39) (para. 51).		

Earlier reputed sign	CTM application	Case No
RSC-ROYAL SHAKESPEARE COMPANY  ROYAL SHAKESPEARE COMPANY	ROYAL SHAKESPEARE	T-60/10
The unfair advantage taken of the distinctive character or the repute of the earlier trade mark consists in the fact that the image of the mark with a reputation or the characteristics which it projects will be transferred to the goods covered by the mark applied for, with the result that the marketing of those goods can be made easier by that association with the earlier mark with a reputation (para. 48).		

Relevant consumer

The concept of 'unfair advantage' focuses on benefit to the later mark rather than harm to the earlier mark; what is prohibited is the exploitation of the earlier mark by the proprietor of the later mark. Accordingly, the existence of the injury consisting of unfair advantage obtained from the distinctive character or the repute of the earlier mark must be assessed **by reference to average consumers of the goods or services for which the later mark is applied for** (judgment of 27/11/2008, C-252/07, 'Intel',

paras 35, 36; judgment of 12/03/2009, C-320/07P, 'nasdaq', paras 46-48; judgment of 07/12/2010, T-59/08, 'NIMEI LA PERLA MODERN CLASSIC', para. 35).

The assessment of unfair advantage

In order to determine whether the use of a sign takes unfair advantage of the distinctive character or the repute of the mark, it is necessary to undertake an **overall assessment** which takes into account all the factors relevant to the circumstances of the case (judgment of 10/05/2007, T-47/06, 'nasdaq', para. 53, confirmed, on appeal, by judgment of 12/03/2009, C-320/07P, 'nasdaq'; see also judgment of 23/10/2003, C-408/01 'Adidas', paras 29, 30, 38; judgment of 27/11/2008, C-252/07 'Intel', paras 57, 58, 66; and judgment of 24/03/2011, C-552/09P, 'Kinder', para. 53).

The misappropriation of the distinctiveness and repute of the earlier mark presupposes an **association** between the respective marks, which **makes possible the transfer of attractiveness and prestige** to the sign applied for. An association of this kind will be more likely in the following circumstances.

1. Where the earlier mark possesses a **strong reputation or a very strong (inherent) distinctive character**, because in such a case it will be both more tempting for the applicant to try to benefit from its value and easier to associate it with the sign applied for. Such marks will be recognised in almost any context, exactly because of their outstanding distinctiveness or 'good' or 'special' reputation, in the sense that it reflects an image of excellence, reliability or quality, or some other positive message, which could positively influence the choice of the consumer as regards goods of other producers (judgment of 12/07/2011, C-324/09, 'L'Oréal and others', para. 44). The stronger the distinctive character of the earlier mark, the more likely it is that, when encountering a later identical or similar mark, the relevant public will associate it with that earlier mark (judgment of 06/07/2012, T-60/10, 'ROYAL SHAKESPEARE', para. 27).
2. Where the degree of similarity between the **signs** at issue is high. The more similar the marks are, the more likely it is that the later mark will bring the earlier mark with a reputation to the mind of the relevant public (judgment of 06/07/2012, T-60/10, 'ROYAL SHAKESPEARE', para. 26; see, by analogy, judgment of 27/11/2008, C-252/07, 'Intel', para. 44).
3. Where there is a **special connection** between the goods/services which allows for some of the qualities of the opponent's goods/services to be attributed to those of the applicant. This will be particularly so in the case of **neighbouring markets**, where a 'brand extension' would seem more natural, as in the example of *pharmaceuticals* and *cosmetics*; the healing properties of the former may be presumed in the latter when it bears the same mark. Similarly, the Court has held that certain drinks (Classes 32 and 33) commercialised as improving sexual performance were linked to the properties of the goods in Class 5 (pharmaceutical and veterinary products and substances) for which the earlier mark, Viagra, was registered (judgment of 25/01/2012, T-332/10 'VIAGUARA', para. 74). Conversely, such a link was not found between *credit card services* and *cosmetics*, as it was thought that the image of the former is not transferable to the latter, even though their respective users largely coincide.

4. Where, in view of its special attractiveness and prestige, the earlier mark may be **exploited even outside its natural market sector**, for example, by licensing or merchandising. In this case, if the applicant uses a sign identical or similar to the earlier mark, for goods for which the latter is already exploited, it will obviously profit from its de facto value in that sector (see decision of 16/03/2012, R 1074/2011-5, 'Twitter').

The applicant's intention is not a material factor. Taking unfair advantage of the distinctiveness or the repute of a trade mark may be a deliberate decision, for example where there is a clear exploitation and free riding on the coat-tails of a famous mark, or an attempt to trade upon the reputation of a famous mark. However, taking unfair advantage does not necessarily require a deliberate intention to exploit the goodwill attached to someone else's trade mark. The concept of taking unfair advantage 'concerns the risk that the image of the mark with a reputation or the characteristics which it projects are transferred to the goods covered by the mark applied for, with the result that the marketing of those goods is made easier by that association with the earlier mark with a reputation' (judgment of 19/06/2008, T-93/06, 'Mineral Spa', para. 40, judgment of 22/03/2007, T-215/03, 'VIPS', para. 40, judgment 30/01/2008, T-128/06, 'Camelo', para. 46).

Therefore, bad faith is not in itself a condition for the application of Article 8(5) CTMR, which only requires that the advantage be '**unfair**', in that there is **no justification** for the applicant's profit. However, where the evidence shows that the applicant is clearly acting in bad faith, there will be a strong indication of unfair advantage. The existence of bad faith may be inferred from various factors, such as an obvious attempt by the applicant to imitate an earlier sign of great distinctiveness as closely as possible, or where there is no apparent reason why it chose for its goods a mark which includes such a sign.

Finally, the concept of unfair advantage in Article 8(5) CTMR does not relate to the **detriment** caused to the reputed mark. Accordingly, an advantage taken by a third party of the distinctive character or the repute of the mark may be unfair, even if the use of the identical or similar sign is not detrimental to the distinctive character or to the repute of the mark or, more generally, to its proprietor. It is, therefore, not necessary for the opponent to show that the applicant's benefit is detrimental to its economic interests or to the image of its mark (unlike with tarnishing, see below), as in most cases the 'borrowed' distinctiveness/prestige of the sign will principally affect the applicant's competitors, that is, traders dealing in identical/similar/neighbouring markets, by putting them at a competitive disadvantage. However, the possibility of simultaneous detriment to the opponent's interests should not be ruled out completely, especially in instances where use of the applied-for sign could affect the opponent's merchandising schemes, or would hinder its plans to penetrate a new market sector.

Cases on unfair advantage*Risk of unfair advantage established*

Earlier reputed sign	CTM application	Case No
INTEL	INTELMARK	C-252/07 (Advocate General Opinion)
<p>In her opinion in the <i>Intel</i> preliminary ruling, Advocate General Sharpston referred to unfair advantage as follows: ‘The concepts of taking unfair advantage of the distinctive character or repute of the mark in contrast must be intended to encompass “instances where there is clear exploitation and free-riding on the coat-tails of a famous mark or an attempt to trade upon its reputation”. Thus by way of example Rolls Royce would be entitled to prevent a manufacturer of whisky from exploiting the reputation of the Rolls Royce mark in order to promote his brand. It is not obvious that there is any real difference between taking advantage of a mark’s distinctive character and taking advantage of its repute; since however nothing turns on any such difference in the present case, I shall refer to both as free-riding’ (para. 33).</p>		

Earlier reputed sign	CTM application	Case No
CITIBANK et al		T-181/05
<p>‘...the reputation of the trade mark CITIBANK in the European Community in regard to banking services is not disputed. That reputation is associated with features of the banking sector, namely, solvency, probity and financial support to private and commercial clients in their professional and investment activities.</p> <p>‘...there is a clear relationship ... between the services of customs agencies and the financial services offered by banks such as the applicants, in that clients who are involved in international trade and in the import and export of goods also use the financial and banking services which such transactions require. It follows that there is a probability that such clients will be familiar with the applicants’ bank given its extensive reputation at international level.</p> <p>‘In those circumstances, the Court holds that there is a high probability that the use of the trade mark applied for, CITI, by customs agencies, and therefore for financial agency activities in the management of money and real estate for clients, may lead to free-riding, that is to say, it would take unfair advantage of the well-established reputation of the trade mark CITIBANK and the considerable investments undertaken by the applicants to achieve that reputation. That use of the trade mark applied for, CITI, could also lead to the perception that the intervener is associated with or belongs to the applicants and, therefore, could facilitate the marketing of services covered by the trade mark applied for. That risk is further increased because the applicants are the holders of several trade marks containing the component “citi” (paras 81-83).</p>		

Earlier reputed sign	CTM application	Case No
SPA	MINERAL SPA	T-93/06
<p>MINERAL SPA (f or soaps, <i>perfumeries, essential oils, preparations for body and beauty care, preparations for the hair, dentifrices</i> in Class 3) could take unfair advantage of the image of the earlier trade mark SPA and the message conveyed by it in that the goods covered by the contested application would be perceived by the relevant public as supplying health, beauty and purity. It is not a question of whether toothpaste and perfume contain mineral water, but whether the public may think that the goods concerned are produced from or with mineral water (paras 43, 44).</p>		

Earlier reputed sign	Case No
L'Oréal et al	C-324/09 (preliminary ruling)
<p>According to L'Oréal et al, the defendants manufactured and imported perfume which was 'smell-like' of L'Oréal's fragrances but sold at a considerably lower price, using packaging which 'took a wink' at the get-up covered by L'Oréal's marks. The comparison lists used by the defendants present the perfumes which they market as being an imitation or a replica of goods bearing a trade mark with repute. Under Directive 84/450, comparative advertising which presents the advertiser's products as an imitation of a product bearing a trade mark is inconsistent with fair competition and thus unlawful. Therefore, any advantage gained by the advertiser through such advertising will have been achieved as a result of unfair competition and must be regarded as taking unfair advantage of the reputation of that mark (para. 79).</p>	



Earlier reputed sign	CTM application	Case No
NASDAQ		T-47/06
<p>'Taking account of the fact that the financial and stock market listing services supplied by the intervener under its trade mark NASDAQ and, therefore, the trade mark NASDAQ itself, undeniably presents a certain image of modernity and that image can be transferred to sports equipment and, in particular, to the high tech composite materials which would be marketed by the applicant under the mark applied for, which the applicant appears to recognise implicitly by stating that the word 'nasdaq' is descriptive of its main activities.</p> <p>Therefore, in light of that evidence, and taking account of the similarity of the marks at issue, the importance of the reputation and the highly distinctive character of the trade mark NASDAQ, it must be held that the intervener has established prima facie the existence of a future risk, which is not hypothetical, of unfair advantage being drawn by the applicant, by the use of the mark applied for, from the reputation of the trade mark NASDAQ. There is therefore no need to set aside the contested decision on that point' (paras 60, 61).</p>		

Earlier reputed sign	CTM application	Case No
RSC-ROYAL SHAKESPEARE COMPANY 	ROYAL SHAKESPEARE	T-60/10
<p>There is a certain proximity and link between <i>entertainment services</i> and <i>beer</i>, even a certain similarity due to their complementarity. The public in the United Kingdom would be able to make a link with the Royal Shakespeare Company (RSC) when seeing a beer with the contested mark ROYAL SHAKESPEARE in a supermarket or in a bar. The contested mark would benefit from the power of attraction, the reputation and the prestige of the earlier mark for its own goods and services, which would attract the consumers' attention thanks to the association with RSC, thereby gaining a commercial advantage over its competitors' goods. The economic advantage would consist of exploiting the effort expended by RSC to establish the reputation and the image of its earlier mark without paying any compensation in exchange. That equates to an unfair advantage (para. 61).</p>		

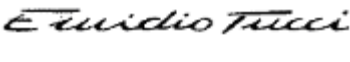
Earlier reputed sign	CTM application	Case No
VIAGRA	VIAGURA	T-332/10
<p>While recognising that the primary function of a trade mark was as an indicator of origin, the General Court held that a mark could also serve to transmit other messages, concerning particular qualities or characteristics of the designated goods or services, or the images and sensations projected by the mark itself, such as luxury, lifestyle, exclusivity, adventure or youth. In this sense, a trade mark possessed an intrinsic economic value that was autonomous and distinct to that of the goods or services for which it was registered (para. 57).</p> <p>The risk of taking unfair advantage encompasses cases of manifest exploitation or parasitism of a mark with reputation, namely the risk of transferring the image of the mark with reputation or the characteristics projected by it to the goods covered by the mark applied for, thus facilitating the marketing of those goods through association with the earlier mark with reputation (para. 59).</p> <p>The Court concluded that, even if the drinks claimed by the mark applied for would not in reality produce the same benefit as the 'immensely well-known' pharmaceutical for the treatment of erectile dysfunction, what was important was that the consumer, because of the transfer of positive associations projected by the image of the earlier mark, would be inclined to purchase such drinks in the expectation of finding similar qualities, such as an increase in libido (paras 52 and 67).</p>		

Earlier reputed sign	CTM application	Case No
EMILIO PUCCI 		T-373/09 (appeal pending C-582/12 P) (cases R 770/2008-2 and R 826/2008-2)
<p>Although the applicant's cosmetic products are dissimilar to the opponent's clothes, they both fall squarely within the realm of products which are often sold as luxury items under famous marks of well-known designers and manufacturers. Taking into account that the earlier mark is very well known and that the commercial contexts in which the goods are promoted are relatively close, BoA concluded that consumers of luxury clothes will make a connection between the applicant's mark for soaps, perfumery, essential oils, cosmetics and hair lotions in Class 3 and the famous mark 'EMILIO PUCCI', an association which will produce a commercial benefit as per the Board's findings (BoA para. 129).</p> <p>BoA concluded that there was a strong likelihood that the applicant could exploit the reputation of the opponent's mark for its own benefit. The use of the mark applied for in connection with the goods and services mentioned above will almost certainly draw the relevant consumer's attention to the opponent's highly similar and very well-known mark. The applicant will become associated with the aura of luxury that surrounds the 'EMILIO PUCCI' brand. Many consumers are likely to think that there is a direct connection between the goods of the applicant on the one hand, and the famous Italian fashion house on the other, perhaps in the form of a licensing agreement. The applicant could take unfair advantage of the fact that the public knows the trade mark 'EMILIO PUCCI' well in order to introduce its own highly similar trade mark without incurring any great risk and the costs of introducing a totally unknown trade mark onto the market (BoA para. 130).</p> <p>The General Court confirmed the BoA findings.</p>		

Risk of unfair advantage denied

Earlier reputed sign	CTM application	Case No
O2 		R 2304/2010-2
<p>The Board of Appeal found that (1) the marks have very limited similarities and are dissimilar overall; (2) the use of the common designation 'O2' is descriptive in the mark applied for; and (3) taking the completely different areas of use – and the descriptive use of the common element – there can be no possibility of the applicant benefiting from the distinctive character of the earlier mark, even if there may be an overlap in the relevant public (para. 55).</p>		

Earlier reputed sign	CTM application	Case No
VIPS	VIPS	T-215/03
<p>The earlier mark VIPS has a reputation for restaurants, in particular fast food chains. However, it was not proven that it also enjoys any particular prestige. The term VIPS is laudatory in itself and extensively used in this manner. Therefore, it cannot be 'diluted'. There is no explanation as to how the sales of software products under the mark VIPS could possibly benefit from their association with a fast-food chain, even if a link were made.</p>		

Earlier reputed sign	CTM application	Case No
SPA	SPA-FINDERS	T-67/04
<p>SPA has a reputation for <i>mineral water</i> in the Benelux. The contested mark, SPA FINDERS, covers <i>publications, catalogues, magazines, newsletters, travel agency services</i>. The General Court declared that there was no detrimental link between the signs. The sign SPA is also used to denote the town of SPA and the racing circuit of the same name. There is no evidence of unfair advantage or any kind of exploitation of the fame of the earlier mark. The word SPA in the mark applied for only denotes the kind of publication concerned.</p>		

3.4.3.2 Detriment to distinctiveness

The nature of the injury

Detriment to the distinctive character of an earlier reputed mark (also referred to as 'dilution', 'whittling away' or 'blurring') is caused when that mark's ability to identify the goods/services for which it is registered and used as coming from its proprietor is weakened because use of a later similar mark leads to dispersion of the identity of the earlier reputed mark by making it less distinctive or unique (judgment of 27/11/2008, C-252/07, 'Intel', para. 29).

Article 8(5) CTMR states that a proprietor of a reputed mark may oppose CTM applications which, without due cause, 'would be detrimental to the *distinctive character* of earlier reputed marks' (emphasis added). Clearly, therefore, the object of protection is the distinctiveness of the earlier reputed mark. As demonstrated in the Guidelines, Part C, Opposition, Section 2, Identity and Likelihood of Confusion, Chapter 4, Distinctiveness, 'distinctiveness' refers to the greater or lesser capacity of a mark to identify the goods/services for which it has been registered as coming from a particular undertaking. Therefore, Article 8(5) CTMR protects reputed marks against a reduction

of their distinctive quality by a later similar mark even where the later mark relates to dissimilar goods/services.

Although Article 8(5) CTMR only refers to conflicts between dissimilar goods/services, in its judgment of 09/01/2003, C-292/00, 'Davidoff' and judgment of 23/10/2003, C-408/01, 'Adidas', the Court held that this article also covers similar or identical goods/services.

The protection provided in Article 8(5) CTMR, therefore, acknowledges that the unrestrained use of a reputed mark by third parties, even on dissimilar goods, will eventually reduce the distinctive quality or uniqueness of that reputed mark. For example, if Rolls Royce were used on restaurants, pants, candy, plastic pens, yard brushes etc. its distinctiveness would eventually be dispersed and its special hold upon the public would be reduced – even in relation to cars for which it is reputed. Consequently, the Rolls Royce mark's ability to identify the goods/services for which it is registered and used as coming from its proprietor would be weakened in the sense that consumers of the goods for which the reputed mark is protected and reputed will be less inclined to associate it *immediately* with the owner who has built up the trade mark's reputation. This is because, for those consumers, the mark now has several or many 'other' associations where it previously had one.

Relevant consumer

Detriment to the distinctive character of the earlier reputed mark must be assessed by reference to the average consumers of the goods and services *for which that mark is registered*, who are reasonably well informed and reasonably observant and circumspect (judgment of 27/11/2008, C-252/07 'Intel', para. 35).

The assessment of detriment to distinctiveness

Detriment to the distinctiveness of the earlier reputed mark occurs where use of a later similar mark reduces the distinctive quality of the earlier reputed mark. However, this cannot be found to occur merely because the earlier mark has a reputation and is identical with or similar to the mark applied for – such an approach would apply an automatic and indiscriminate finding of likelihood of dilution against all marks that are similar to reputed trade marks and would negate the requirement of proving detriment.

The Court held in 'Intel' that Article 4(4)(a) TMD (the equivalent to Article 8(5) CTMR) must be interpreted as meaning that proof that the use of the later mark would be detrimental to the distinctive character of the earlier mark requires evidence of a 'change in the economic behaviour' of the average consumer of the goods/services for which the earlier mark was registered, or a serious likelihood that such a change will occur in the future.

The Court has further elaborated on the concept of 'change in the economic behaviour of the average consumers' in its judgment of 14/11/2013 C-383/12P 'Wolf head image'. It indicated that it is an objective condition which cannot be deduced solely from subjective elements such as consumer's perceptions. The standard of proof is higher. Therefore, in order to find a detriment or risk of detriment to the distinctiveness of the earlier trade mark, the mere fact that consumers note the presence of a new sign similar to an earlier sign is not sufficient of itself (paras. 35-40).

Whilst the opponent does not need to submit evidence of *actual* detriment, it must convince the Office by adducing evidence of a serious future risk – which is not merely hypothetical – of detriment. The opponent may do this by submitting evidence that proves a likelihood of detriment on the basis of logical deductions made from an analysis of the probabilities (and not mere suppositions) and by taking account of the normal practice in the relevant commercial sector as well as all the other circumstances of the case (see judgment of 16/04/2008, T-181/05, ‘Citi’, para. 78 as cited in judgment of 22/05/2012, T-570/10, ‘Wolf head image’, para. 52 and confirmed in the appeal by judgment of 14/11/2013, C-383/12P, paras. 42-43).

First use

Detriment to the distinctive character is characterised by an ‘avalanche effect’, meaning that the first use of a similar mark in a distinct market may not, in itself, dilute the identity or ‘uniqueness’ of the reputed mark but, over time, this would be the result because this first use may trigger further acts of use by different operators, thus leading to its dilution or detriment to its distinctive character.

The Court has held that the first use of an identical or similar mark may suffice to cause actual and present detriment to the distinctive character of the earlier mark or to give rise to a serious likelihood that such detriment will occur in the future (judgment of 27/11/2008, C-252/07 ‘Intel’, para. 75). In opposition proceedings before the Office, use of the contested sign may not have occurred at all. In this regard, the analysis that the Office carries out assumes that the future use of the contested sign, even if it were first use, may trigger further acts of use by different operators, thus leading to dilution by blurring. As seen above, the wording of Article 8(5) CTMR provides for this by stating that use of the applied-for mark without due cause ‘**would ... be** detrimental to the distinctiveness or repute of the earlier mark’.

Nevertheless, as set out above, the opponent bears the burden of showing that the actual or future use caused, or is likely to cause, detriment to the distinctiveness of the earlier reputed mark.

Inherent distinctiveness of the earlier mark

The Court has stated that ‘the more “unique” the earlier mark appears, the greater the likelihood that the use of a later identical or similar mark will be detrimental to its distinctive character’ (judgment of 27/11/2008, C-252/07 ‘Intel’ para. 74 and judgment of 28/10/2008, T-131/09 ‘Botumax’). Indeed, the earlier mark must possess an exclusive character in the sense that it should be associated by the consumers with a single source of origin – since it is only in this case that a likelihood of detriment to distinctiveness may be envisaged. If the same sign, or a variation thereof, is already in use in connection with a range of different goods, there can be no immediate link with any of the goods it distinguishes and, thus, there will be little or no room for further dilution.

Accordingly, ‘... the risk of dilution appears, in principle, to be lower if the earlier mark consists of a term which, because of a meaning inherent in it, is very common and frequently used, irrespective of the earlier mark consisting of the term at issue. In such

a case, re-use of the term in question by the contested trade mark is less likely to result in a dilution of the earlier mark' (judgment of 22/03/2007, T-215/03, 'VIPS', para. 38).

If, therefore, the mark is suggestive of a characteristic shared by a wide range of goods, the consumer is more likely to associate it with the specific feature of the product that it alludes to rather than with another mark.

In its judgment of 25/05/2005, T-67/04, 'Spa-Finders', the General Court confirmed the finding that the use of the mark SPA-FINDERS for *publications* and *travel agency* services would neither blur the distinctiveness, nor tarnish the reputation, of the mark SPA for *mineral water*. The term 'spa' in SPA-FINDERS may be used otherwise than in a trade mark context since it 'is frequently used to designate, for example, the Belgian town of Spa and the Belgian racing circuit of Spa-Francorchamps or, in general, places for hydrotherapy such as hammams or saunas, [and consequently] the risk of detriment to the distinctive character of the mark SPA seems to be limited' (para. 44).

Thus, if the applicant shows that the earlier sign or the element that gives rise to similarity is commonplace and is already used by different undertakings in various sectors of the market, it may successfully refute the existence of a likelihood of dilution because it will be difficult to accept that the attractiveness of the earlier mark risks being diluted if it is not particularly unique.

Cases on dilution by blurring

Dilution established

Earlier reputed sign	CTM application	Case No
BOTOX	BOTUMAX	T-131/09
Reputed for <i>pharmaceuticals for the treatment of wrinkles</i>	<i>Cosmetics, pharmaceuticals, and other health-related goods, and printed matters</i>	
<p>'However, in the present case, the word element "botox" has no inherent meaning, but is a fanciful term with which the public will be faced only in relation to the goods covered by the widely known earlier trade mark. Consequently, the use of that word element or a similar word element by another trade mark registered for goods which may concern the general public will unquestionably result in the dilution of the distinctive character of the widely known earlier trade mark' (para. 99).</p> <p>'That is the position with regard, first, to the cosmetics and pharmaceutical preparations in Classes 3 and 5 and, secondly, to the goods in Class 16 covered by the earlier marks, which include magazines or journals, the distribution of which may be widespread. The risk that the use of an identical or similar trade mark would be detrimental to the distinctive character of a widely known earlier trade mark is greater where that other mark will be used in respect of goods intended for a wide public' (para. 100).</p>		

Dilution denied

Earlier reputed sign	CTM application	Case No
VIPS	VIPS	T-215/03
Reputed for <i>fast food restaurant chain</i> in Class 42	<i>Computer programming for hotel services</i> in Class 42	
<p>'So far as concerns, first, detriment to the distinctive character of the earlier mark by the use without due cause of the mark applied for, that detriment can occur where the earlier mark is no longer capable of arousing immediate association with the goods for which it is registered and used (<i>SPA-FINDERS</i>, paragraph 34 above, paragraph 43). That risk thus refers to the "dilution" or "gradual whittling away" of the earlier mark through the dispersion of its identity and its hold upon the public mind (Opinion of Advocate General Jacobs in <i>Adidas-Salomon and Adidas-Benelux</i>, paragraph 36 above, point 37)' (para. 37).</p> <p>'As far as concerns, first, the risk that the use of the mark applied for would be detrimental to the distinctive character of the earlier mark, in other words the risk of "dilution" and "gradual whittling away" of that mark, as explained in paragraphs 37 and 38 above, it must be pointed out that the term "VIPS" is the plural form, in English, of the abbreviation VIP ("Very Important Person"), which is widely and frequently used both internationally and nationally to describe famous personalities. In those circumstances, the risk that the use of the mark applied for would be detrimental to the distinctive character of the earlier mark is limited' (para. 62).</p> <p>'That same risk is also even less probable in the present case as the mark applied for covers the services "Computer programming relating to hotel services, restaurants, cafés", which are directed at a special and necessarily more limited public, namely the owners of those establishments. The consequence is that the mark applied for, if registration is allowed, will probably be known, through use, only by that relatively limited public, a factor which certainly reduces the risk of dilution or gradual whittling away of the earlier mark through the dispersion of its identity and its hold upon the public mind' (para. 63).</p>		

Earlier reputed sign	CTM application	Case No
SPA	SPA-FINDERS	T-67/04
Reputed for <i>mineral waters</i> in Class 32	<i>Printed publications including catalogues, magazines, newsletters</i> in Class 16, <i>Travel agency</i> in Class 39	
<p>'In the present case, the Court finds that the applicant does not put forward any evidence to support the conclusion that there is a risk of detriment to the distinctive character of the mark SPA by the use of the mark SPA-FINDERS. The applicant stresses the alleged immediate link which the public will establish between SPA and SPA-FINDERS. It infers from that link that there is detriment to the distinctive character. As the applicant acknowledged at the hearing, the existence of such a link is not sufficient to demonstrate the risk of detriment to the distinctive character. The Court notes, moreover, that since the term "spa" is frequently used to designate, for example, the Belgian town of Spa and the Belgian racing circuit of Spa-Francorchamps or, in general, places for hydrotherapy such as hammams or saunas, the risk of detriment to the distinctive character of the mark SPA seems to be limited' (para. 44).</p>		

3.4.3.3 Detriment to repute

The nature of the injury

The final type of damage under Article 8(5) CTMR concerns harming the earlier mark by way of detriment to its repute. It can be seen as a step beyond blurring in that the mark is not merely weakened but actually degraded by the link which the public makes with the later mark. Detriment to repute, also often referred to as 'dilution by tarnishing' or simply as 'tarnishing', relates to situations where use of the contested mark without due cause is likely to devalue the image or the prestige that a mark with reputation has acquired among the public.

The reputation of the earlier trade mark may be tainted or debased in this way, either when it is reproduced in an obscene, degrading or inappropriate context, or in a context which is not inherently unpleasant but which proves to be incompatible with a particular image the earlier trade mark has acquired in the eyes of the public, due to the promotional efforts of its owner. The likelihood of such detriment may arise in particular from the fact that the goods or services offered by the third party possess a characteristic or a quality which is liable to have a negative impact on the image of the mark (judgment of 18/06/2009, C-487/07, 'L'Oréal', para. 40). For example, if a reputed mark for gin were used by a third party on liquid detergent, this would reverberate negatively on the reputed mark in a way that makes it less attractive.

In short, tarnishment occurs where there is an association between the earlier reputed mark, either at the level of signs or at the level of goods, which is injurious to the earlier trade mark's repute.

Relevant consumer

As with dilution by blurring, detriment to the reputation of the earlier mark must be assessed by reference to average consumers of the goods and services for which that mark is registered, who are reasonably well informed and reasonably observant and circumspect (judgment of 27/11/2008, C-252/07 'Intel', para. 35 and judgment of 07/12/2010, T-59/08, 'Nimei La Perla Modern Classic', para. 35).

The assessment of tarnishment

In order to establish detriment to the repute of an earlier mark, the mere existence of a connection in the mind of the consumer between the marks is neither sufficient nor determinative. Such a connection must certainly exist, but, *in addition*, the goods/services covered by the later mark must provoke the kind of negative or detrimental impact set out below when associated with the reputed mark.

Tarnishment occurs most frequently where the reputed mark is linked to goods which evoke undesirable or questionable mental associations which conflict with the associations or image generated by legitimate use of the reputed trade mark by its proprietor (decision of 12/03/2012, R 297/2011-5, 'KAPPA', para. 36).

Therefore, to prove tarnishment, the opponent must show that use of the applicant's trade mark would prompt inappropriate or negative mental associations with the earlier trade mark, or associations conflicting with the image it has acquired in the market (decision of 23/11/2010, R 240/2004-2, 'WATERFORD', para. 89).

For example, if a mark that is associated in the minds of the public with an image of health, dynamism and youth is used for *tobacco products*, the negative connotation conveyed by the latter would contrast strikingly with the image of the former (see further examples below). For tarnishment to occur, therefore, there must be some characteristic or qualities of the goods/services on which the contested mark is used that are potentially detrimental to the reputation of the earlier mark (judgment of 22/03/2007, T-215/03, 'VIPS', para. 67).

Earlier reputed sign	CTM application	Case No
WATERFORD		R 0240/2004-2
Reputed for <i>crystal products, including glassware</i> in Class 21	<i>Alcoholic beverages, namely wines produced in the Stellenbosch district, South Africa</i> in Class 33	
<p>'Tarnishment or debasement of a trade mark's image through association with something inappropriate may happen when the trade mark is used, on the one hand, in an unpleasant, obscene or degrading context or, on the other hand, in a context which is not inherently unpleasant but which proves to be incompatible with the trade mark's image. This may be the case when the reputed mark might be linked with goods of poor quality or which evoke undesirable or questionable mental associations which conflict with the associations or image generated by legitimate use of the reputed trade mark by its proprietor, or when the reputed mark is linked to goods which are incompatible with the quality and prestige associated with that mark, even though it is not a matter of inappropriate use of the mark itself, or, eventually, when the reputed mark's verbal or figurative element is amended or altered in a negative way' (para. 88).</p>		

Frequently opponents argue that the goods/services of the applicant are of inferior quality or that the opponent cannot control the quality of such goods/services. The Office does not accept such an argument, per se, as a means of demonstrating detriment. Proceedings before the Office do not provide for assessing the quality of goods and services which, apart from being highly subjective, would not be feasible in cases where the goods and services are not identical or in situations where the contested sign has not yet been put to use.

Therefore, in assessing whether the use of the contested trade mark is likely to damage the reputation of the earlier trade mark, the Office can only consider the goods and services as indicated in the specification of each trade mark. Consequently, for the purposes of the analysis by the Office, the harmful effects of the use of the contested sign in connection with the goods and services applied for must derive from the nature and usual characteristics of the goods at issue in general, not their quality in particular instances. This approach does not leave the opponent without protection because, in any event, where a later mark is used on low quality goods/services in a manner that calls to mind an earlier reputed mark, this would normally take unfair advantage of the distinctive character or the repute of the earlier trade mark or be detrimental to its distinctiveness.

Cases on dilution by tarnishing*Tarnishment established*

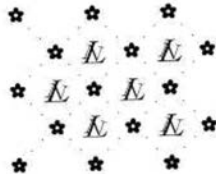

Earlier reputed sign	CTM application	Case No
<p>KAPPA</p> 	KAPPA	R 0297/2011-5
Reputed for <i>sports clothing and footwear</i>	<i>tobacco products, cigarettes, cigars amongst others</i>	
<p>The contested application was filed for tobacco and related goods in Class 34. Smoking tobacco is universally considered to be an extremely unhealthy habit. For this reason, the use of the sign 'KAPPA' for tobacco and related goods is likely to prompt negative mental associations with the respondent's earlier marks or associations conflicting with and detrimental to their image of a healthy lifestyle (para. 38).</p>		

Earlier reputed sign	CTM application	Case No
	SPA ^{CE} NK	R 0417/2008-1
Reputed for <i>mineral waters</i>	<i>Scouring and polishing preparations and substances; pot pourri; incense; incense sticks; room fragrances and articles for perfuming rooms</i>	
<p>The pleasant notions conveyed generally by mineral water do not mix seamlessly with detergents and scouring preparations. Use of marks that contain the word SPA for goods conveying such different connotations is likely to damage, or tarnish, the distinctive character of the earlier mark (para. 101).</p> <p>'Mineral water is not pleasantly associated by most consumers with incense or pots pourris. The use, in order to distinguish fragrances and incense, of a mark containing a word (SPA) that Belgian consumers strongly associate to bottled drinking water is therefore likely to damage the attractive and suggestive power that the brand, according to the evidence, currently enjoys' (para. 103).</p>		

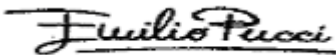
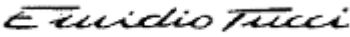
Earlier reputed sign	CTM application	Case No
		R 2124/2010-1
Reputed for goods in Classes 18 and 25	<i>Scientific, nautical, surveying, weighing, measuring, signalling, checking (supervision), life-saving and teaching apparatus and instruments; amongst others.</i>	
<p>The opponent demonstrated that the prestigious image of its trade marks is linked to the traditional manufacturing method of its fine leather goods, which are handmade by master craftsmen who work only with top-quality raw materials. It is this image of luxury, glamour and exclusivity, combined with the exceptional quality of the product that the opponent has always striven to convey to the public, as the evidence adduced testifies. In fact, this image would be quite incompatible with goods of a strongly industrial and technological nature, such as electric meters, scientific microscopes, batteries, supermarket cash registers, fire-extinguishing apparatus or other instruments, for which the applicant intends to use its trade mark (para. 28).</p> <p>What would be detrimental to the image of its trade marks, which the opponent has carefully fostered for decades, is the use of a trade mark that recalls its own and is applied to goods characterised, in the public's perception, by a significant technological content (whereas a fine-leather article is rarely associated with technology) or as having an industrial origin (whereas fine leather goods are traditionally associated with craftsmanship) (para. 29).</p> <p>The use of a trade mark that is practically identical to a trade mark that the public has come to perceive as synonymous with fine leather goods of excellent manufacture for technical apparatus or electrical tools of all kinds will diminish its attraction, that is, its reputation, amongst the public who knows and values the earlier trade marks (para. 30).</p>		

Earlier reputed sign	CTM application	Case No
EMILIO PUCCI 		
Reputed for clothing and footwear for women	<i>Class 3: Bleaching preparations and other substances for laundry use; cleaning, polishing, scouring and abrasive preparations; (abrasive preparations) soaps; perfumery, essential oils, cosmetics, hair lotions; dentifrices. Class 21: Materials for cleaning purposes and steelwool</i>	T-373/09 (cases R 770/2008-2 and R 826/2008-2)
<p>In its decisions of R 0770/2008-2 and R 0826/2008-2 it is stated that the risk of detriment to repute can occur where the goods and services covered by the mark applied for have a characteristic or a quality which may have a negative influence on the image of an earlier mark with a reputation on account of it being identical or similar to the mark applied for. The General Court confirmed the Board's finding, adding that due to the great similarity between the signs at issue, the strong distinctive character of the Italian mark and its notoriety in the Italian market, it can be concluded that there is a link between the signs in conflict, a link which could damage the idea of exclusivity, luxury and high quality and therefore be a detriment to the notoriety of the Italian mark (para. 68).</p>		

Tarnishment denied

Earlier reputed sign	CTM application	Case No
 SEVE TROPHY		T-192/09
Reputed for <i>organisation of sports competitions</i>	Class 9	
<p>The Court noted that the opponent had not demonstrated any risk of injury to the reputation of the earlier marks, since it did not indicate how the attractiveness of the earlier marks would be diminished by the use of the contested mark on the contested goods. Specifically, it did not allege that the contested goods have any characteristic or quality that could have a negative influence on the image of the earlier marks (para. 68).</p>		

Earlier reputed sign	CTM application	Case No
SPA	SPA-FINDERS	
Reputed for <i>mineral waters</i> in Class 32	<i>Printed publications including catalogues, magazines, newsletters</i> in Class 16, <i>Travel agency</i> in Class 39	T-67/04
<p>'This detriment is made out where the goods for which the mark applied for is used appeal to the public's senses in such a way that the earlier mark's power of attraction is diminished' (para. 46).</p> <p>'In the present case, SPA and SPA-FINDERS designate very different goods consisting, on the one hand, in mineral waters and, on the other, in publications and travel agency services. The Court finds that it is therefore unlikely that the goods and services covered by the mark SPA-FINDERS, even if they turn out to be of lower quality, would diminish the power of attraction of the mark SPA' (para. 49).</p>		

Earlier reputed sign	CTM application	Case No
VIPS	VIPS	T-215/03
Reputed for <i>fast food restaurant chain</i> in Class 42	<i>Computer programming for hotel services</i> in Class 42	
<p>'The risk of that detriment (to the repute of the earlier mark) can, inter alia, occur where those goods or services have a characteristic or a quality which may have a negative influence on the image of an earlier mark with a reputation on account of its being identical or similar to the mark applied for' (para. 39).</p> <p>'It must be pointed out in this connection that, although some fast food chain marks have an indisputable reputation, they do not, in principle and failing evidence to the contrary, convey a particularly prestigious or high quality image, the fast food sector being associated with other qualities such as speed or availability and, to a certain extent, youth, since many young people frequent that type of establishment' (para. 57)</p> <p>'... it is appropriate to examine the risk that the use of the mark applied for could be detrimental to the reputation of the earlier mark. As was explained in paragraph 39 above, at issue is the risk that the association of the earlier mark with a reputation with the goods or services covered by the identical or similar mark applied for results in the earlier mark being damaged or tarnished, as a result of the fact that the goods or services covered by the mark applied for have a characteristic or a particular quality which may have a negative influence on the earlier mark's image' (para. 66)</p> <p>'In that regard, it must be stated that the services covered by the mark applied for do not have any characteristic or quality capable of establishing the likelihood of detriment of that type to the earlier mark. The applicant neither cited, nor a fortiori proved, any characteristic or quality of that kind. The mere existence of a connection between the services covered by the conflicting marks is neither sufficient nor determinative. It is true that the existence of such a connection strengthens the probability that the public, faced with the mark applied for, would also think of the earlier mark. However, that factor is not, in itself, sufficient to diminish the earlier mark's power of attraction. Such an outcome can arise only if it is established that the services covered by the mark applied for have characteristics or qualities which are potentially detrimental to the reputation of the earlier mark. Such evidence has not been adduced in the present case' (para. 67).</p>		

3.4.4 Proving the risk of injury

3.4.4.1 Standard and burden of proof

In opposition proceedings **detriment or unfair advantage may be only potential**, as confirmed by the conditional wording of Article 8(5) CTMR, which requires that the use of the applied-for mark without due cause '**would take** unfair advantage of, **or be** detrimental to the distinctiveness or repute of the earlier mark'.

In opposition proceedings **actual detriment or unfair advantage** will occur only exceptionally given that in most cases the applicant will not have effectively used its mark when the dispute arises. Nevertheless, such a possibility should not be ruled out completely and if there is evidence of actual use or damage, it will have to be considered and given appropriate weight.

However, the fact that detriment or unfair advantage may be only potential does not mean that a mere possibility is sufficient for the purposes of Article 8(5) CTMR. The risk of detriment or unfair advantage must be **serious**, in the sense that it is **foreseeable (i.e. not merely hypothetical) in the ordinary course of events**. Therefore, it is not enough to merely show that detriment or unfair advantage cannot be excluded in general, or that it is only remotely possible. The proprietor of the earlier mark **must adduce prima facie evidence** of a future risk, which is **not hypothetical**, of unfair advantage or of detriment (judgment of 06/06/2012, T-60/10 'ROYAL SHAKESPEARE', para. 53). As explained below, it is insufficient for the opponent only

to refer in general terms to an unfair advantage of, or detriment to, the distinctive character or reputation of its earlier marks without submitting convincing evidence of actual detriment or cogent arguments establishing a serious, not merely hypothetical, potential risk of detriment.

As a rule, **general allegations** (such as merely citing the relevant CTMR wording) of detriment or unfair advantage will **not be sufficient** in themselves for proving potential detriment or unfair advantage: the opponent must adduce evidence and/or develop a cogent line of argument to demonstrate specifically how, taking into account both marks, the goods and services in question and all the relevant circumstances, the alleged injury might occur. **Merely showing the reputation and good image of the earlier marks, without further substantiation by way of evidence and/or reasoning is not sufficient** (decision of 15/2/2012, R 2559/2010-1 'GALLO', paras 38, 39, and the Court case-law cited therein). This is shown in the following paragraphs.

The precise threshold of proof which must be satisfied to show that the risk of potential detriment or unfair advantage is **serious** and not merely hypothetical will be determined case by case, following the criteria indicated below.

As mentioned in paragraph 3.1.4.2 above when discussing the burden of proof for establishing reputation, Article 76(1) CTMR requires the opponent to submit and prove all the facts on which its opposition is based. Moreover, Rule 19(2)(c) CTMIR requires the opponent to **submit evidence or arguments** showing that use without due cause of the trade mark applied for would take unfair advantage of, or be detrimental to, the distinctive character or the repute of the earlier trade mark.

Therefore, within the period for completing the substantiation of the opposition, the **opponent bears the burden** of showing that the actual or future use of the applied-for mark has caused, or is likely to cause, detriment to the distinctiveness or the repute of the earlier mark, or that it has taken, or is likely to take, unfair advantage thereof.

In discharging this burden of proof, the opponent cannot merely contend that detriment or unfair advantage would be a necessary consequence flowing automatically from the use of the sign applied for, owing to the strong reputation of the earlier mark. Even where the earlier mark is highly reputed, unfair advantage or detriment must be **properly proved and/or argued** taking into account both marks and the relevant goods and services, since otherwise marks with reputation would enjoy blanket protection against identical or similar signs for virtually any kind of product. This would be clearly inconsistent with the wording and spirit of Article 8(5) CTMR, because in such a case reputation would become the sole requirement, rather than being only one of the several conditions provided for therein.

Therefore, where the opponent claims **actual detriment or unfair advantage**, it must submit indications and evidence of the **kind** of detriment suffered, or of the nature of the unfair advantage taken by the applicant. The opponent must also show that this **resulted from the use** of the sign applied for. In doing so, the opponent may rely on a variety of indications, depending on the kind of detriment or unfair advantage pleaded, such as a considerable decrease in sales of the goods bearing the mark, or a loss of clientele, or a decline of the degree of recognition of the earlier mark among the public.

However, in the case of **potential detriment or unfair advantage**, the exercise will necessarily be more abstract, as the detriment or unfair advantage in question has to be evaluated *ex ante*.

To that end, the proprietor of the earlier mark is not required to demonstrate actual and present harm to his mark. When it is foreseeable that such injury would ensue from the use that might be made of the CTM application, the proprietor of the earlier mark is not required to wait for it actually to occur in order to be able to prohibit registration of the CTM application. The proprietor of the earlier mark must, however, prove that there is a **serious risk** that such an injury will occur in the future (judgment of 27/11/2008, C-252/07 'Intel', para. 38, judgment of 07/12/2010, T-59/08, 'NIMEI LA PERLA MODERN CLASSIC', para. 33, judgment of 29/03/2012, T-369/10 'BEATLE', para. 61, judgment of 06/07/2012 (appeal dismissed in C-294/12 P), T-60/10 'ROYAL SHAKESPEARE' para. 53 and judgment of 25/01/2012, T-332/10 'VIAGUARA', para. 25).

Such a finding may be established, in particular, on the basis of logical deductions made from an analysis of the probabilities and by taking account of the normal practice in the relevant commercial sector as well as all the other circumstances of the case (judgment of 10/05/2007, T-47/06, 'nasdaq' para. 54, upheld on appeal (C-320/07 P), judgment of 16/04/2008, T-181/05 'CITI' para. 78, and judgment of 14/11/2013, C-383/12P 'Wolf head image' paras 42-43).

However, considering that in such cases the matter to be proved is the likelihood of a future event and that, by definition, the opponent's arguments cannot in themselves amount to evidence, it will often be necessary to base certain conclusions on **legal presumptions**, that is, on logical assumptions or deductions resulting from the application of the rules of probability to the facts of the specific case. One such presumption was mentioned by the Court, when it stated that 'the stronger the earlier mark's distinctive character and reputation, the easier it will be to accept that detriment has been caused to it' (judgment of 14/09/1999, C-375/97, 'General Motors', para. 30). It is also clear from case-law that the more immediately and strongly the mark is brought to mind by the sign, the greater the likelihood that the current or future use of the sign is taking, or will take, unfair advantage of the distinctive character or the repute of the mark (judgment of 06/07/2012, T-60/10 'ROYAL SHAKESPEARE', para. 54, judgment of 18/06/2009, C-487/07 'L'Oréal and Others' para. 44, and judgment of 27/11/2008, C-252/07 'Intel', paras 67-69).

These are rebuttable presumptions, which the applicant may contest and disprove by submitting appropriate evidence; they are not conclusive presumptions.

In addition, if the type of detriment or unfair advantage argued in the specific case is of such a nature that presupposes the fulfilment of certain **particular conditions of fact** (e.g. exclusive character of the earlier mark, qualitative aspects of reputation, a given image etc.), these facts will also have to be proven by the opponent, who must submit appropriate evidence.

Finally, as noted by the Court in its judgment of 07/12/2010, T-59/08, 'NIMEI LA PERLA MODERN CLASSIC' (paras 57, 58), although a likelihood of confusion between the two marks at issue is not required to demonstrate that the later mark takes unfair advantage of the earlier mark, where such likelihood is established on the basis of facts, this will be taken as proof that unfair advantage has been taken or that, at least, there is a serious risk of such injury in the future.

3.4.4.2 Means of evidence

Where the opponent claims **potential** detriment or unfair advantage, it must prove any conditions of fact that might be necessary in particular cases for giving rise to a serious, non-hypothetical risk of detriment or unfair advantage, by submitting evidence of the kind mentioned in the paragraph below on proving actual detriment or unfair advantage.

Conclusions as to the risk of future injury may also be established on the basis of **logical deductions** made from an analysis of the probabilities and by taking account of the normal practice in the relevant commercial sector as well as all the other circumstances of the case (judgment of 16/12/2010, joined cases T-345/08 and T-357/08 'BOTOLIST' para. 82 and judgment of 06/07/2012, T-60/10, 'ROYAL SHAKESPEARE', para. 53, and judgment 14/11/13, C-383/12 P 'Wolf head image', paras 42-43).

Where the opponent claims **actual** detriment or unfair advantage, it can use all the means of evidence provided for in **Article 78 CTMR** for proving this. For example, it may prove an actual decrease of trade mark awareness by reference to opinion polls and other documentary evidence. The rules governing the evaluation and probative value of such evidence are the same as those mentioned in paragraph 3.1.4.3 and paragraph 3.1.4.4 above in relation to the evidence required for proving reputation.

3.5 Use without due cause

The last condition for the application of Article 8(5) CTMR is that use of the sign applied for should be without due cause.

However, if it is established that none of the three types of injury exists, the registration and use of the mark applied for cannot be prevented, as the existence or absence of due cause for the use of the mark applied for is, in those circumstances, irrelevant (judgment of 22/03/2007 T-215/03 'VIPS', para. 60, and judgment of 07/07/2010, T-124/09 'Carlo Roncato', para. 51).

The existence of a cause justifying the use of the trade mark applied for is a **defence** which the applicant may raise. Therefore, it **is up to the applicant to show that it has due cause to use the mark applied for**. This is an application of the general rule according to which 'he who asserts must prove' which is the expression of the ancient rule *ei qui affirmat incumbit probatio* (decision of 01/03/2004, R 145/2003-2 – 'T CARD OLYMPICS (FIG. MARK) / OLYMPIC', para. 23). Case-law clearly establishes that when the proprietor of the earlier mark has shown that there is either actual and present injury to its mark or, failing that, a serious risk that such injury will occur in the future, it is for the proprietor of the later mark to establish that there is due cause for the use of that mark (judgment of 06/07/2012, T-60/10, 'ROYAL SHAKESPEARE', para. 67 and, by analogy, judgment of 27/11/2008, C-252/07 'Intel', para. 39).

In the absence of any indications in the evidence providing an apparent justification for the applicant's use of the contested mark, the lack of due cause must be generally **presumed** (see to that effect judgment of 29/03/2012, T-369/10, 'Beatle', para. 76 and the case-law there cited, appeal C-294/12 P dismissed). However, the applicant may

avail itself of the possibility of rebutting such a presumption by showing that it has a legitimate justification that entitles it to use the mark.

For example, such a situation could be envisaged if the applicant had been using the sign for dissimilar goods in the relevant territory before the opponent's mark was applied for, or acquired a reputation, especially where such a coexistence has not in any way affected the distinctiveness and repute of the earlier mark.

Interpreting Article 5(2) of Directive 89/104 (whose legislative content is essentially identical to that of Article 8(5) CTMR), the Court ruled that the proprietor of a trade mark with a reputation might be obliged, pursuant to the concept of 'due cause' within the meaning of that provision, to tolerate the use by a third party of a sign similar to that mark in relation to a product that was identical to that for which that mark had been registered, if it was demonstrated that that sign was being used before that mark had been filed and that the use of that sign in relation to the identical product was in good faith (judgment of 06/02/2014, C-65/12, 'The Bulldog', para. 60). The Court gave further detailed factors to be considered in the assessment of due cause on account of prior use.

The case-law below shows that due cause may be found where the applicant establishes that it cannot reasonably be required to abstain from use of the mark (for example, because its use of the sign is a generic use to indicate the type of goods and services – whether by generic words or generic figurative devices), or where it has some specific right to use the mark for the goods and services (for example, it shows that a relevant coexistence agreement permits its use of the sign).

The condition of due cause is not fulfilled merely by the fact that (a) the sign is particularly suitable for identifying the products for which it is used, (b) the applicant has already used this sign for these products or similar products within and/or outside the relevant territory of the European Union, or (c) the applicant invokes a right ensuing from a filing over which the filing of the opponent's trade mark takes precedence (see, inter alia, decision of 23/11/2010, R 0240/2004-2 'WATERFORD (fig.)' and decision of 15/06/2009, R 1142/2005-2 'MARIE CLAIRE (fig.)'). Mere use of the sign is not enough – what must be shown is a valid reason justifying that use.

3.5.1 Examples of due cause

3.5.1.1 Due cause was accepted

Case No	Comment
Decision of 02/06/2010, R 1000/2009-1, 'FLEX (fig.)', para. 72	The Board confirmed that the applicant had a due cause within the meaning of Article 8(5) CTMR for inserting the term 'FLEX' in the mark applied for, holding that this term was free from monopolies, since nobody holds exclusive rights in it and it is a suitable abbreviation, in many languages of the Community, to indicate that beds and mattresses are flexible.
Decision of 26/02/2008, R 320/2007-2, 'biscuit packet (3D)/OREO(3D)'	The Board held that the applicant had due cause to represent the series of sandwich-type biscuits in the three-dimensional mark applied for, namely, to indicate to consumers the type of biscuits concerned, as defined by the relevant Spanish legislation.

Case No	Comment
Decision of 30/07/2007, R 1244/2006-1, 'M FRATELLI MARTINI (fig.)'	The Board confirmed that the applicant had two good reasons to use the name MARTINI in the mark applied for: (i) 'MARTINI' is the family name of the founder of the applicant's company, and (ii) the existence of a coexistence agreement from 1990.
Decision of 20/04/2007, R 710/2006-2, 'CAL SPAS'	The Board confirmed that the applicant had due cause to use the term 'SPAS' as it corresponds to one of the generic uses of the term 'spa' as indicated by the Court of First Instance in the 'Mineral Spa' judgment Case T-93/06.
Decision of 23/01/2009, R 237/2008 & R 263/2008-1, 'CARLO RONCATO'	The business affairs of the Roncato family, showing that both parties had the right to use the name 'RONCATO' as a trade mark in the suitcase and trunk sector, were held to constitute 'due cause' for use of the 'RONCATO' name in the contested trade mark.
Decision of 25/08/2011, Opposition decision B 1 708 398 'Posten AB v Česká pošta s.p.'	It was held that the applicant had due cause to use the figurative element of a postal horn since that device is widely used as a long-standing and historical symbol of postal services (trade mark registrations and internet evidence was submitted showing 29 European countries use the postal horn as a symbol for their postal services).

3.5.1.2 Due cause was not accepted

Case No	Comment
Judgment of 06/07/2012, T-60/10, 'ROYAL SHAKESPEARE', paras 65-69	The General Court held that, in order to establish due cause, it is not use per se of the contested trade mark that is required, but a reason justifying the use of that trade mark. In this case, the applicant merely claimed to have 'demonstrated how and for which product the contested trade mark has been used in the past' but, even assuming that that aspect is relevant, provided no additional indication or explanation. Accordingly, the Court held that the applicant had not established due cause for such use.
Judgment of 25/03/2009, T-21/07, 'L'Oréal SA', para. 43	The General Court held that there was no due cause, since it had not been shown that the word 'spa' had become so necessary to the marketing of cosmetic products that the applicant could not reasonably be required to refrain from use of the mark applied for. The argument that 'spa' was of descriptive and generic character for cosmetic products was rejected, since such character does not extend to cosmetic products but only to one of their uses or destinations.
Judgment of 16/04/2008, T-181/05 'CITI', para. 85	The General Court held that the use of the trade mark CITI in just one EU Member State (Spain) could not constitute due cause because, first, the extent of geographical protection of the national trade mark did not correspond to the territory covered by the trade mark applied for, and, second, the legal validity of that national registration was subject to dispute before the national courts. By the same token, the ownership of the domain 'citi.es' was held to be irrelevant.
Judgment of 10/05/2007, T-47/06, 'NASDAQ', para. 63, confirmed by CJ, C-327/07 P	The Court held that the only argument put forward before the Board of Appeal in respect of due cause (namely, that the word 'nasdaq' had been chosen because it is an acronym for 'Nuovi Articoli Sportivi Di Alta Qualità') was not convincing, noting that prepositions are not generally included in acronyms.

Case No	Comment
Decision of 23/11/2010, R 240/2004-2 'WATERFORD (fig.)'	<p>Contrary to the applicant's arguments that there was due cause because the term 'WATERFORD' was allegedly very common in names and trade marks, the Board held that the applicant had failed to give any evidence of market coexistence of WATERFORD marks nor had it submitted any element from which it would be possible to infer that the relevant general public (in the UK) considers Waterford as a commonplace geographical name.</p> <p>To the extent that such arguments play a role in the assessment of uniqueness of a sign in order to establish the existence of the necessary link in the mind of the relevant public between the signs at issue, the Board held that, nevertheless, once such uniqueness had been established, such arguments cannot serve as due cause.</p> <p>Further, the Board noted that the condition of due cause is not fulfilled merely by the fact that (a) the sign is particularly suitable for identifying the products for which it is used, (b) the applicant has already used this sign for these products or similar products within and/or outside the relevant territory of the European Union, or (c) the applicant invokes a right ensuing from a filing over which the filing of the opponent's trade mark takes precedence.</p>
Decision of 06/10/2006, R 428/2005-2 'TISSOT'	<p>The Board held that the applicant's claim (unsubstantiated by any evidence) that the sign TISSOT is derived from the name of a trading company associated with the applicant's company since the early 1970s, would, even if proven, not amount, on its own, to 'due cause', within the meaning of Article 8(5) CTMR. People who inherit a surname that happens to coincide with a famous trade mark should not assume that they are entitled to use it in business in a manner that would unfairly take advantage of the reputation that has been built up by the efforts of the brand owner.</p>
Decision of 18/08/2005, R 1062/2000-4, 'GRAMMY'	<p>The applicant argued that 'GRAMMY' is an internationally easy and nice-sounding abbreviation of the applicant's family name (Grammatikopoulos). The Board rejected this argument as insufficient to establish the due cause that could prevent the application of Article 8(5) CTMR.</p>

Case No	Comment
Decision of 15/06/2009, R 1142/2005-2, 'MARIE CLAIRE (fig.)'	<p>Due cause under Article 8(5) CTMR means that notwithstanding the detriment caused to, or the unfair advantage taken of, the distinctive character or reputation of the earlier trade mark, the registration and use by the applicant of the mark for the goods applied for may be justified, if the applicant cannot be reasonably required to abstain from using the contested mark, or if the applicant has a specific right to use the mark for with such goods which takes precedence over the earlier trade mark invoked in the opposition proceedings. In particular, the condition of due cause is not fulfilled merely by the fact that (a) the sign is particularly suitable for identifying the products for which it is used, (b) the applicant has already used this sign for these products or similar products within and/or outside the relevant territory of the Community, or (c) the applicant invokes a trade mark with a filing date which is earlier than the opponent's trade mark (decision of 25/04/2001 in R 283/1999-3 HOLLYWOOD / HOLLYWOOD).</p> <p>With regards to the tolerance of the proprietor of the earlier mark, the Board held that such tolerance was merely for magazines and not for goods closer to its market sector (i.e. textiles). It noted that national case-law showed that while protection exists for each party within its own field of business, extension should be refused when they come closer to the other party's field of activities and could infringe upon their rights.</p> <p>In light of these factors, the Board held that the coexistence did not constitute due cause permitting registration of a CTM.</p>
Judgment of 26/09/2012, T-301/09, 'Citigate', paras 116, 125 and 126	<p>As regards the applicant's argument that it has due cause to use the mark applied for (CITIGATE), because it has used a variety of marks consisting of or containing CITIGATE in relation to the goods and services for which registration is sought, the Court stated the following: it should be noted that the documents produced by the applicant simply show that there are various companies whose business name contains the word CITIGATE and a number of domain names which also contain that word. That evidence is not sufficient to establish due cause, because it does not demonstrate actual use of the CITIGATE mark.</p> <p>As regards the applicant's argument that it has due cause to use the mark applied for since <u>the interveners have acquiesced to the use</u> of CITIGATE in relation to the goods and services covered by the application for registration, the Court stated that <u>the possibility cannot be excluded that, in certain cases, the coexistence of earlier marks on the market could reduce (...) the likelihood of a connection being made between two marks in accordance with Article 8(5).</u></p> <p>In the present case, coexistence was not proven.</p>

***GUIDELINES FOR EXAMINATION IN THE
OFFICE FOR HARMONIZATION IN THE
INTERNAL MARKET (TRADE MARKS AND
DESIGNS) ON COMMUNITY TRADE MARKS***

PART D

CANCELLATION

SECTION 2

SUBSTANTIVE PROVISIONS

Table of Contents

1	General Remarks	4
1.1	The grounds for cancellation.....	4
1.2	<i>Inter partes</i> proceedings.....	4
1.3	The consequences of revocation and invalidity.....	4
2	Revocation	5
2.1	Introduction	5
2.2	Non-use of the CTM – Article 51(1)(a) CTMR	5
2.2.1	Burden of proof	5
2.2.2	Genuine use	6
2.2.3	Period of time to be considered.....	6
2.2.4	Proper reasons for non-use.....	7
2.3	CTM becoming the common name (generic term) – Article 51(1)(b) CTMR.....	7
2.3.1	Burden of proof	7
2.3.2	Point in time to be considered	7
2.3.3	Relevant public	7
2.3.4	Common name	8
2.3.5	Defence for the proprietor.....	8
2.4	CTM becoming misleading – Article 51(1)(c) CTMR.....	8
2.4.1	Burden of proof	9
2.4.2	Point in time to be considered	9
2.4.3	Standards to be applied.....	9
2.4.4	Examples	9
3	Absolute grounds for invalidity.....	10
3.1	CTM registered contrary to Article 7 – Article 52(1)(a) CTMR	10
3.1.1	Burden of proof	10
3.1.2	Points in time to be considered	10
3.1.3	Standards to be applied.....	11
3.2	Defence against a claim of lack of distinctiveness	11
3.3	Bad faith – Article 52(1)(b) CTMR	11
3.3.1	Relevant point in time	12
3.3.2	Concept of bad faith	12
3.3.2.1	Factors likely to indicate the existence of bad faith	12
3.3.2.2	Factors unlikely to indicate the existence of bad faith	16
3.3.3	Proof of bad faith	17
3.3.4	Relation to other CTMR provisions	17
3.3.5	Extent of invalidity.....	17
4	Relative Grounds for Invalidity.....	18
4.1	Introduction	18
4.2	Grounds under Article 53(1) CTMR	18

4.2.1	Standards to be applied.....	18
4.2.2	Points in time to be considered	19
4.2.2.1.	For the assessment of enhanced distinctiveness or reputation	19
4.2.2.2.	Application based on Article 53(1)(c) in conjunction with Article 8(4) CTMR 19	
4.3	Grounds under Article 53(2) CTMR – Other earlier rights	19
4.3.1	A right to a name/right of personal portrayal	20
4.3.2	Copyright	21
4.3.3	Other industrial property rights	23
4.4	Non-use of the earlier mark	23
4.5	Defences against an invalidity application based on relative grounds	24
4.5.1	Consent to registration	24
4.5.2	Earlier applications for declaration of invalidity or counterclaims.....	25
4.5.3	Acquiescence	25
4.5.3.1	Examples rejecting the acquiescence claim	26
4.5.3.2	Examples (partially) accepting the acquiescence claim	27
5	Res Judicata	27

1 General Remarks

1.1 The grounds for cancellation

Pursuant to Article 56(1) CTMR, cancellation proceedings comprise applications for revocation and for declarations of invalidity.

The grounds for revocation are established in Article 51 CTMR. The grounds for invalidity are established in Article 52 CTMR (absolute grounds) and Article 53 CTMR (relative grounds). The CTMIR deals with revocation and invalidity in Rules 37 to 41.

1.2 *Inter partes* proceedings

Cancellation proceedings are never initiated by the Office itself. The initiative lies with the applicant for cancellation, even in cases based on absolute grounds for invalidity.

Article 56(1) CTMR establishes the *locus standi* that the applicant must have in order to file an application for revocation or for a declaration of invalidity. For further details, please see the Guidelines, Part D, Cancellation, Section 1, Cancellation Proceedings, paragraphs 2.1 and 4.1.

1.3 The consequences of revocation and invalidity

According to Article 55(1) CTMR, in the event of **revocation**, and to the extent that the rights of the proprietor have been revoked, the CTM will be deemed not to have the effects specified in the CTMR as from the date of the application for revocation. This is particularly relevant in cases where a request for revocation on grounds of non-use is followed by the surrender of the CTM. In this regard, the General Court has declared that the party who applies for revocation has a legitimate interest in continuing the revocation proceedings in spite of the surrender of the CTM by its proprietor, as the continuation of the revocation proceedings may result in a declaration of non-use preventing, pursuant to Article 112(2)(a) CTMR, the proprietor of the CTM from requesting the conversion of their mark (order of 24/10/2013, T-451/12, 'Stormberg', para. 48) (for the Office's new practice on surrenders, see the Guidelines, Part D, Cancellation, Section 1, Cancellation Proceedings, paragraphs 7.3.1 and 7.3.2).

An earlier date on which one of the grounds for revocation occurred may be fixed by the Office if this is requested by one of the parties, provided that the requesting party shows a legitimate legal interest in this respect. On the basis of information available in the relevant case file, it must be possible to accurately determine the earlier date. The earlier date should, in any event, be set after the five year 'grace period' that the CTM proprietor has after the registration of a CTM pursuant to Article 15 CTMR (see decision of 28/07/2010, 3349 C, 'ALPHATRAD', confirmed by decision of 08/10/2012, R 0444/2011-1, paras 48-50 and judgment of 16/01/2014, T-538/12).

According to Article 55(2) CTMR, in the event of a **declaration of invalidity**, the CTM will be deemed not to have had, as from the outset, the effects specified in the CTMR.

2 Revocation

2.1 Introduction

According to Article 51(1) CTMR, there are three grounds for revocation:

- the CTM has not been put to genuine use during a continuous period of five years;
- the CTM has become generic due to acts/inactivity of its proprietor;
- the CTM has become misleading due to the use made by its proprietor or with its consent.

These grounds are examined in further detail in the sections below. According to Article 51(2) CTMR, where the grounds for revocation exist only for some of the registered goods and services, the CTM proprietor's rights will be revoked only for those goods and services.

2.2 Non-use of the CTM – Article 51(1)(a) CTMR

According to Article 51(1)(a) CTMR, if within a continuous period of five years after the CTM has been registered and before the filing of the application for cancellation the CTM has not been put to genuine use, within the meaning of Article 15 CTMR, then the CTM must be revoked unless there are proper reasons for non-use.

Pursuant to Article 51(2) CTMR, if the CTM has been used for only some of the goods and services for which it is registered, the revocation will be limited to the non-used goods and services.

As regards **procedural aspects** of the submission of the evidence (time limits for submitting evidence, additional rounds for observations and submission of additional relevant evidence, translation of evidence, etc.), see the Guidelines, Part D, Cancellation, Section 1, Cancellation Proceedings.

The practice rules applicable to the **substantive assessment** of proof of use of earlier rights in opposition proceedings are applicable to the assessment of requests for revocation based on non-use (see the Guidelines, Part C, Opposition, Section 6, Proof of Use, Chapter 2, Substantive Law). However, there are a number of particularities to be taken into account in the context of revocation proceedings, which will be examined below.

2.2.1 Burden of proof

Pursuant to Rule 40(5) CTMIR, the burden of proof lies with the CTM proprietor.

The role of the Office is to assess the evidence put before it in the light of the parties' submissions. The Office cannot determine *ex officio* genuine use of earlier marks. It has no role in collecting evidence itself. Even proprietors of purportedly well-known marks must submit evidence to prove genuine use of their marks.

2.2.2 Genuine use

According to Rule 40(5) in conjunction with Rule 22(3) CTMIR, the indications and evidence for submitting proof of use shall consist of indications concerning the place, time, extent and nature of use of the contested trade mark for the goods and services for which it is registered.

As indicated above, the assessment of genuine use (including place, time, extent and nature of use) is the same in cancellation proceedings and in opposition proceedings. The detailed considerations in the Guidelines, Part C, Opposition, Section 6, Proof of Use, Chapter 2, Substantive Law should be followed.

Lack of genuine use for some of the contested goods/services in a revocation case implies the revocation of the registered CTM for those goods/services. Consequently, great care must be taken when assessing the evidence of use in revocation proceedings regarding **the use for the registered (and contested) goods/services**.

Case No	Comment
R 1857/2011-4 AQUOS	The CTM was registered for <i>angling articles; angling equipment; angling accessories</i> in Class 28. The Board confirmed the Cancellation Division decision and maintained the CTM for <i>fishing rods</i> and the unchallenged <i>fishing lines</i> in Class 28. The Board concurred with the Cancellation Division that the evidence furnished in order to prove use of the contested CTM showed genuine use in relation to 'fishing rods' and that these goods are sufficiently distinct from the broad categories of <i>angling articles</i> and <i>angling equipment</i> to form coherent sub-categories. This finding was not challenged by the appellant.

2.2.3 Period of time to be considered

The relevant date is the date on which the **application for revocation** was filed.

- The CTM is subject to revocation only if it has been registered for more than five years on that date.
- If this condition is fulfilled, the CTM must have been genuinely used within the five years preceding that date (i.e. the five-year period is always counted backwards from the relevant date).

There is one **exception**: where genuine use of the CTM started or was resumed within the three months preceding the date on which the application for revocation was filed, such use will be disregarded where preparations for the commencement or resumption of use only began after the CTM proprietor became aware that the request for revocation might be filed (Article 51(1)(a) CTMR).

The burden of proof for this exception is on the applicant for revocation, who must file evidence that it made the CTM proprietor **aware of its intention** to file an application for revocation.

2.2.4 Proper reasons for non-use

The detailed considerations in the Guidelines, Part C, Opposition, Section 6, Proof of Use, Chapter 2, Substantive Law and in particular paragraph 2.11 should be followed.

2.3 CTM becoming the common name (generic term) – Article 51(1)(b) CTMR

A CTM will be revoked if, as a result of action or inaction on the part of the proprietor, it has become the common name in trade for a product or service for which it was registered.

2.3.1 Burden of proof

The burden is on the applicant for revocation to prove that the term has become the common name in the trade as a result of either:

- action; or
- inaction

on the part of the proprietor.

The Office shall examine the facts in accordance with Article 76(1) CTMR within the scope of factual submissions made by the revocation applicant (judgment of 13/09/2013, T-320/10, 'Castel', para. 28). In doing so, it may take into consideration obvious and well-known facts. However, it shall not go beyond the legal arguments presented by the revocation applicant. If a request for revocation is based only on Article 51(1)(b) CTMR, the trade mark could not then be revoked due to being, e.g., against public order and morality.

2.3.2 Point in time to be considered

The applicant for revocation must prove that the trade mark has become the common name in trade for the product or service in question after the date of registration of the CTM, although facts or circumstances that took place between application and registration can be taken into account. The fact that the sign was, at the date of application, the common name used in trade for the goods or services in respect of which registration was sought would only be relevant in the context of an invalidity action.

2.3.3 Relevant public

A Community trade mark is liable to be revoked in accordance with Article 51(1)(b) CTMR if it has become the common name for the product or service not just among some but among the vast majority of the relevant public, including those involved in the trade for the product or service in question (judgment of 29/04/2004, C-371/02, 'Bostongurka', paras 23 and 26). It is not necessary for the sign to become the common name for a product from the point of view of both sellers and end users of the

product (judgment of 06/03/2014, C-409/12, 'Kornspitz', para. 30). It is sufficient that the sellers of the finished product do not inform their customers that the sign has been registered as a trade mark or offer their customers assistance, which includes an indication of the origin of the goods for sale (judgment of 06/03/2014, C-409/12, 'Kornspitz', paras 23-25).

2.3.4 Common name

A sign is regarded as the 'common name in the trade' if it is established practice in the trade to use the term in question to designate the goods or services for which it is registered (see the Guidelines, Part B, Examination, Section 4, Absolute grounds for refusal, Chapter 2, Absolute Grounds, paragraph 2.4). It is not necessary to prove that the term directly describes a quality or characteristic of the goods or services, but merely that it is actually used in the trade to refer to those goods or services. The distinctive force of a trade mark is always more likely to degenerate when a sign is suggestive or apt in some way, especially if it has positive connotations that lead others to latch on to its suitability for designating not just a particular producer's product or service but a particular type of product or service (decision of 30/01/2007, 1020 C, 'STIMULATION', paras 22, 32 et seq.).

The fact that a trade mark is used as a synonym for a specific product or service is an indication that it has lost its ability to differentiate the goods or services in question from those of other undertakings. One indication that a trade mark has become generic is when it is commonly used verbally to refer to a particular type or characteristic of the goods or services. However, this is not in itself decisive: it must be established whether the trade mark is still capable of differentiating the goods or services in question from those of other undertakings.

The absence of any alternative term or the existence of only one long, complicated term may also be an indication that a sign has become the common name in the trade for a specific product or service.

2.3.5 Defence for the proprietor

Where the proprietor of the CTM has done what could reasonably have been expected in the particular case (e.g. organised a TV campaign or placed advertisements in newspapers and relevant magazines), the CTM cannot be revoked. The proprietor must then check whether its trade mark appears in dictionaries as a generic term; if it does, the proprietor can request from the publisher that in future editions the trade mark will be accompanied by an indication that it is a registered trade mark (Article 10 CTMR).

2.4 CTM becoming misleading – Article 51(1)(c) CTMR

If, as a result of use made of the mark by the proprietor or with its consent, the mark is liable to mislead the public, particularly concerning the nature, quality or geographical origin of the goods or services for which it is registered, the CTM can be revoked. In this context, quality refers to a characteristic or attribute rather than a degree or standard of excellence.

2.4.1 Burden of proof

The Office shall examine the facts in accordance with Article 76(1) CTMR within the scope of factual submissions made by the revocation applicant (judgment of 13/09/2013, T-320/10, 'Castel', para. 28). In doing so, it may take into consideration obvious and well-known facts. However, it shall not go beyond the legal arguments presented by the applicant for revocation.

The burden of proof that the mark has become misleading rests on the applicant for revocation, who must further prove that it is the use made by the proprietor that causes the misleading effect. If the use is made by a third party, the burden is on the applicant for revocation to prove that the proprietor has consented to that use, unless the third party is a licensee of the proprietor.

2.4.2 Point in time to be considered

The applicant for revocation must prove that the trade mark has become liable to mislead the public, particularly concerning the nature, quality or geographical origin of the goods or services in question, after the date of registration of the CTM. If the sign was already deceptive or liable to deceive the public at the date of application, this would be relevant in the context of an invalidity action.

2.4.3 Standards to be applied

The Guidelines concerning Examination contain details of the criteria to be applied when assessing whether a CTM application complies with Article 7(1)(g) CTMR (Guidelines, Part B, Examination, Section 4, Absolute Grounds for Refusal, Chapter 2, Absolute grounds (Article 7 CTMR), paragraph 2.7). The criteria are comparable to those applied in revocation proceedings under Article 51(1)(c) CTMR

2.4.4 Examples

A trade mark composed of, or containing, a geographical indication will, as a rule, be perceived by the relevant public as a reference to the place from where the goods originate. The only exception to this rule is where the relationship between the geographical name and the products is manifestly so fanciful (for example, because the place is not known, and unlikely to become known, to the public as the place of origin of the goods in question) that consumers will not make such a connection.

In this regard, the trade mark MÖVENPICK OF SWITZERLAND was revoked because the goods in question were produced (according to the facts) solely in Germany, not in Switzerland (decision of 12/02/2009, R 0697/2008-1 – 'MÖVENPICK OF SWITZERLAND')

Moreover, where a trade mark containing the word elements 'goats' and cheese' and a figurative element clearly depicting a goat is registered for 'goats' cheese', and use is proven for cheese not made from goats' milk, the CTM will be revoked.

Where a trade mark containing the word elements 'pure new wool' is registered for 'clothing' and use is proven for clothing manufactured from artificial fibres, the CTM will be revoked.

Where a trade mark containing the words 'genuine leather' or the corresponding pictogram is registered for 'shoe wear' and use is proven for shoes not made of leather, the CTM will be revoked. 

3 Absolute grounds for invalidity

3.1 CTM registered contrary to Article 7 – Article 52(1)(a) CTMR

If, at the time of its application, an objection could be raised to the CTM under any of the grounds listed in Article 7 CTMR, it can be declared invalid.

3.1.1 Burden of proof

The purpose of invalidity proceedings is, inter alia, to enable the Office to review the validity of the registration of a trade mark and to adopt, where necessary, a position that it should have adopted of its own motion in the registration process in accordance with Article 37(1) CTMR (judgment of 30/05/2013, T-396/11, 'Ultrafilter international', para. 20).

The General Court has ruled that in invalidity proceedings, the Office is not allowed to examine afresh, of its own motion, all the absolute grounds for refusal but only those put forward by the applicant. The CTM enjoys a **presumption of validity and it is for the invalidity applicant to invoke before the Office the specific facts that call the validity of a trade mark into question** (see judgment of 13/09/2013, T-320/10, 'Castel', paras 27-29).

Consequently, the Office shall examine the facts in accordance with Article 76(1) CTMR within the **scope of factual submissions** made by the applicant for the declaration of invalidity (judgment of 13/09/2013, T-320/10, 'Castel', para. 28). In doing so, it may take into consideration obvious and well-known facts. However, it shall **not go beyond the legal arguments presented by the applicant** for the declaration of invalidity.

One of the arguments that the CTM proprietor may put forward against the invalidity applicant's claim is evidence that the CTM has acquired distinctive character following use. See paragraph 3.2. below.

3.1.2 Points in time to be considered

The General Court has held that whether a trade mark should be registered or should be declared invalid must be assessed on the basis of the situation at the date of its application, not of its registration (judgment of 03/06/2009, T-189/07, 'Flugbörse'; confirmed by Order of 23/04/2010, C-332/09 P, 'Flugbörse').

Generally speaking, any developments or events after the date of application or priority date will not be taken into consideration. For example, the fact that a sign has, after the date of application, become the common term used in the trade for the goods or services for which registration was sought is in principle irrelevant for the purposes of examining an invalidity action (it would only be relevant in the context of a revocation action). However, such facts can nevertheless be taken into account where and to the extent that they allow conclusions to be drawn regarding the situation at the date of application of the CTM.

3.1.3 Standards to be applied

The Guidelines concerning Examination contain details of the criteria to be applied when assessing whether a CTM application complies with Article 7 CTMR. The criteria are identical to those applied in invalidity proceedings under Article 52(1)(a) CTMR.

3.2 Defence against a claim of lack of distinctiveness

A trade mark that falls foul of Article 52(1)(a) in conjunction with Article 7(1)(b), (c) or (d) CTMR will not be declared invalid where it has acquired distinctiveness through use (Articles 7(3) and 52(2) CTMR).

The distinctive character acquired following use is, in the context of invalidity proceedings, an exception to the grounds for invalidity of Article 52(1)(a) in conjunction with Article 7(1)(b), (c) and (d) CTMR. Since it is an exception, the **onus of proof** is on the party seeking to rely on it, namely the proprietor of the contested mark. The proprietor of the contested mark is best placed to adduce evidence in support of the assertion that its mark has acquired a distinctive character following the use which has been made of it (e.g. concerning the intensity, geographical extent, duration of use, promotional investment). Consequently, where the proprietor of the contested mark is requested to adduce evidence of distinctive character acquired through use, but fails to do so, the mark must be declared invalid (judgment of 19/06/2014, joined cases C-217/13 and C-218/13, 'Oberbank e.a.', paras 68-71).

The situation will be assessed in accordance with the relevant part of the Guidelines concerning Examination.

The proprietor must demonstrate that either:

- the trade mark acquired distinctive character on or before the date of **application, or the priority date** (Article 7(3) CTMR); or
- distinctive character was acquired after registration (Article 52(2) CTMR).

Evidence of use during the period between the date of application and the date of registration can serve to support a finding of acquired distinctiveness after registration.

3.3 Bad faith – Article 52(1)(b) CTMR

The CTMR considers bad faith only as an absolute ground for the invalidity of a CTM, to be relied on either before OHIM or by means of a counterclaim in infringement proceedings. Therefore, bad faith is not relevant in examination or opposition

proceedings (for opposition proceedings, see judgment of 17/12/2010, T-192/09, 'Seve Trophy', para. 50).

3.3.1 Relevant point in time

The relevant point in time for determining whether there was bad faith on the part of the CTM owner is the time of filing of the application for registration. However, it must be noted that:

- facts and evidence dated prior to filing can be taken into account for interpreting the owner's intention at the time of filing the CTM. Such facts include, in particular, whether there is already a registration of the mark in a Member State, the circumstances under which that mark was created and the use made of it since its creation (see paragraph 3.3.2.1, point 3 below).
- facts and evidence dated subsequent to filing can sometimes be used for interpreting the owner's intention at the time of filing the CTM, in particular whether the owner has used the mark since registration (see paragraph 3.3.2.1, point 3 below).

3.3.2 Concept of bad faith

As observed by Advocate General Sharpston (opinion of 12/03/2009, C-529/07, 'Lindt Goldhase', para. 36), the concept of bad faith referred to in Article 52(1)(b) CTMR is not defined, delimited or even described in any way in the legislation. However, the Court of Justice provided some guidance on how to interpret this concept in its judgment in the same case, as did the General Court in several cases (judgments of 01/02/2012, T-291/09, 'Pollo Tropical chicken on the grill'; of 14/02/2012, T-33/11, 'BIGAB'; and judgment of 13/12/2012, T-136/11, 'Pelikan'). In its preliminary ruling of 27/06/2013, C-320/12, 'Malaysia Dairy', the Court of Justice declared that the concept of bad faith is an autonomous concept of European Union law, which must be given a uniform interpretation in the European Union.

One way to describe bad faith is 'conduct which departs from accepted principles of ethical behaviour or honest commercial and business practices' (opinion of Advocate General Sharpston of 12/03/2009, C-529/07, 'Lindt Goldhase', para. 60; similar decision of 01/04/2009, R 0529/2008-4 – 'FS', para. 14).

In order to find out whether the owner had been acting in bad faith at the time of filing the application, an overall assessment must be made in which all the relevant factors of the individual case must be taken into account. A non-exhaustive list of such factors is given below.

3.3.2.1 Factors likely to indicate the existence of bad faith

Case-law shows three cumulative factors to be particularly relevant:

1. Identity/confusing similarity of the signs: The CTM allegedly registered in bad faith must be identical or confusingly similar to the sign to which the invalidity applicant refers. Although the fact that marks are identical or confusingly similar is not in itself sufficient to show bad faith (regarding identity, see judgment of

01/02/2012, T-291/09, 'Pollo Tropical chicken on the grill', para. 90), a dissimilar or not confusingly similar mark will not support a finding of bad faith.

2. Knowledge of the use of an identical or confusingly similar sign: The CTM owner knew or must have known about the use of an identical or confusingly similar sign by a third party for identical or similar products or services.

There is knowledge, for example, where the parties have been in a business relationship with each other ('could not ignore, and was probably aware that the invalidity applicant had been using the sign for a long time', judgment of 11/07/2013, T-321/10, 'Gruppo Salini', para. 25), or when the reputation of the sign, even as an 'historical' trade mark, is a well-known fact (judgment of 08/05/2014, T-327/12, 'Simca', para. 50).

Knowledge may be presumed to exist ('must have known') on the basis, *inter alia*, of general knowledge in the economic sector concerned or duration of use. The longer the use of a sign, the more likely it is that the CTM owner had knowledge of it (judgment of 11/06/2009, C-529/07, 'Lindt Goldhase', para. 39). However, a presumption of knowledge is less likely if the sign was registered in a non-EU country and there was only a short time between the application for registration in that non-EU country and an application for registration in an EU country (judgment of 01/02/2012, T-291/09, 'Pollo Tropical chicken on the grill', para. 61).

Knowledge of an identical or similar earlier sign for identical or similar goods or services is not sufficient in itself to support a finding of bad faith (judgment of 11/06/2009, C-529/07, 'Lindt Goldhase', paras 40, 48 and 49). For example, it cannot be excluded that, where a number of producers use, on the market, for identical or similar goods, identical or similar signs that could give rise to confusion with the sign for which registration is sought, the CTM owner's registration of the sign may be in pursuit of a legitimate objective. This could be the case where the CTM owner knows, at the time of filing the CTM application, that a third undertaking is making use of the mark covered by that application by giving its clients the impression that it officially distributes the goods sold under that mark, even though it has not received authorisation to do so (judgment of 14/02/2012, T-33/11, 'BIGAB', para. 27).

Similarly, the fact that the applicant knows or should know that, at the time of filing of its application, a third party is using a mark abroad that is liable to be confused with the mark whose registration has been applied for is not sufficient, in itself, to permit the conclusion that the applicant is acting in bad faith within the meaning of that provision (preliminary ruling of 27/06/2013, C-320/12, 'Malaysia Dairy', para. 37).

Knowledge or presumption of knowledge of an existing sign is not required where the CTM owner misuses the system with the intention of preventing any similar sign from entering the market (see, for example, artificial extension of the grace period for non-use in paragraph 3.3.2.1, point 3(c) below).

3. Dishonest intention on the part of the CTM owner: This is a subjective factor that has to be determined by reference to objective circumstances (judgment of 11/06/2009, C-529/07, 'Lindt Goldhase', para. 42). Again, several factors can be relevant. See, for example, the following case scenarios:

- (a) Bad faith is found when it can be inferred that the purpose of the CTM applicant is to ‘free-ride’ on the reputation of the invalidity applicant’s registered marks and to take advantage of that reputation (judgment of 08/05/2014, T-327/12, ‘Simca’, para. 56).
- (b) While it is not a requirement of the CTM system that a CTM owner must at the time of applying for a CTM also have the intention of using it, it could be seen as an indication of dishonest intention if it subsequently becomes apparent that the owner’s sole objective was to prevent a third party from entering the market (judgment of 11/06/2009, C-529/07, ‘Lindt Goldhase’, para. 44).

On the other hand, if there is commercial logic to the filing of the CTM and it can be assumed that the CTM owner intended to use the sign as a trade mark, this would tend to indicate that there was no dishonest intention. For example, this could be the case if there is a ‘commercial trajectory’, such as the registration of a CTM after registration of the mark in a Member State (judgment of 01/02/2012, T-291/09, ‘Pollo Tropical chicken on the grill’, para. 58), if there is evidence of the CTM owner’s intention to develop its commercial activities, for example by means of a licensing agreement (judgment of 01/02/2012, T-291/09, ‘Pollo Tropical chicken on the grill’, para. 67), or if the CTM owner had a commercial incentive to protect the mark more widely, for example an increase in the number of Member States in which the owner generates turnover from goods marketed under the mark (judgment of 14/02/2012, T-33/11, ‘BIGAB’, paras 20 and 23).

The existence of a direct or indirect relationship between the parties prior to the filing of the CTM, for example a pre-contractual, contractual or post-contractual (residual) relationship, can also be an indicator of bad faith on the part of the CTM owner (judgment of 01/02/2012, T-291/09, ‘Pollo Tropical chicken on the grill’, paras 85 to 87; judgment of 11/07/2013, T-321/10, ‘Gruppo Salini’, paras 25 to 32). The CTM owner’s registration of the sign in its own name in such cases can, depending on the circumstances, be considered a breach of honest commercial and business practices.

- (c) One example of a situation that may be taken into account in order to assess whether the proprietor acted in bad faith is where a CTM owner tries to artificially extend the grace period for non-use, for example by filing a repeat application of an earlier CTM in order to avoid the loss of a right as a result of non-use (judgment of 13/12/2012, T-136/11, ‘Pelikan’, para. 27).

This case needs to be distinguished from the situation in which the CTM owner, in accordance with normal business practice, seeks to protect variations of its sign, for example, where a logo has evolved (judgment of 13/12/2012, T-136/11, ‘Pelikan’, paras 36 et seq.).

In addition to the three factors mentioned above, other potentially relevant factors identified in case-law and/or Office practice to assess the existence of bad faith include:

- (i) the circumstances under which the contested sign was created, the use made of it since its creation and the commercial logic underlying the filing of the application for registration of that sign as a CTM (judgment of 14/02/2012,

T-33/11, 'BIGAB', paras 21 et seq.; judgment of 08/05/2014, T-327/12, 'Simca', para. 39).

- (ii) the nature of the mark applied for. Where the sign for which registration is sought consists of the entire shape and presentation of a product, the fact that the CTM owner was acting in bad faith at the time of filing might more readily be established where the competitor's freedom to choose the shape of a product and its presentation is restricted by technical or commercial factors, with the result that the CTM owner is able to prevent its competitors not merely from using an identical or similar sign, but also from marketing comparable products (judgment of 11/06/2009, C-529/07, 'Lindt Goldhase', para. 50).
- (iii) the degree of inherent or acquired distinctiveness enjoyed by the invalidity applicant's sign and the CTM owner's sign, as well as its degree of reputation, even if this is only residual (judgment of 08/05/2014, T-327/12, 'Simca', paras 40, 46 and 49).
- (iv) the fact that the national mark on which the CTM owner has based a priority claim has been declared invalid due to bad faith (decision of 30/07/2009, R 1203/2005-1 – 'BRUTT').
- (v) a request for financial compensation made by the CTM owner to the invalidity applicant if there is evidence that the CTM owner knew of the existence of the earlier identical or confusingly similar sign and expected to receive a proposal for financial compensation from the invalidity applicant (judgment of 08/05/2014, T-327/12, 'Simca', para. 72). **However, in a previous case, the Court considered that** even a seemingly disproportionate request for compensation does not in itself establish bad faith if the invalidity applicant does not provide evidence that the CTM owner could not have been unaware of the existence of the earlier mark. **In this particular case, the Court took into account the fact that in 1994, the CTM owner had registered a trade mark identical to the contested CTM in the Spanish Trade Mark Office (judgment of 01/02/2012, T-291/09, 'Pollo Tropical chicken on the grill', paras 1-22 and 88).**

Finally, the case-law and/or the Office have identified a number of factors that, considered in isolation, are not enough to find bad faith but that, in combination with other relevant factors (to be identified on a case-by-case basis), might indicate the existence of bad faith:

- The fact that an earlier, very similar, CTM was revoked for goods or services in a number of classes is not, in itself, sufficient to allow any conclusions to be drawn as to the CTM owner's intentions at the time of filing the CTM application for the same goods or services (judgment of 13/12/2012, T-136/11, 'Pelikan', para. 45).
- The fact that the application for registration of the contested CTM is filed three months before expiry of the period of grace for the earlier CTMs is not sufficient to counteract factors that show that the CTM owner's intention was to file a modernised trade mark covering an updated list of services (judgment of 13/12/2012, T-136/11, 'Pelikan', paras 50 and 51).
- The filing of applications for declarations that the invalidity applicant's marks are invalid constitutes the legitimate exercise of a CTM owner's exclusive right and cannot in itself prove any dishonest intent on its part (judgment of 13/12/2012, T-136/11, 'Pelikan', para. 66).

- The fact that, after successfully registering the CTM at issue, the CTM owner serves formal notice on other parties to cease using a similar sign in their commercial relations is not in itself an indication of bad faith. Such a request falls within the scope of the rights attaching to the registration of a CTM; see Article 9 CTMR (judgment of 14/02/2012, T-33/11, 'BIGAB', para. 33). However, in circumstances where this request is connected with other factors (e.g. the mark is not being used), it might be an indication of the intention to prevent another party from entering the market.
- The fact that the signs at issue are identical does not establish bad faith where there are no other relevant factors (judgment of 01/02/2012, T-291/09, 'Pollo Tropical chicken on the grill', para. 90). Furthermore, the mere fact that the differences between the CTM at issue and the previous CTM registered by the same proprietor are so insignificant as not to be noticeable to the average consumer cannot establish that the contested CTM is a mere repeat application made in bad faith (judgment of 13/12/2012, T-136/11, 'Pelikan', paras 33-34). The evolution over time of a logo intended as the graphic representation of a mark constitutes normal business practice (judgment of 13/12/2012, T-136/11, 'Pelikan', para. 36).

3.3.2.2 Factors unlikely to indicate the existence of bad faith

Case-law has identified several factors that, in general, are unlikely to prove bad faith.

- Extending the protection of a national mark by registering it as a CTM falls within a company's normal commercial strategy (judgment of 14/02/2012, T-33/11, 'BIGAB', para. 23; judgment of 01/02/2012, T-291/09, 'Pollo Tropical chicken on the grill', para. 58).
- Bad faith cannot be found on the basis of the length of the list of goods and services set out in the application for registration (judgment of 07/06/2011, T-507/08, '16PF', para. 88). As a rule, it is legitimate for an undertaking to seek registration of a mark not only for the categories of goods and services that it markets at the time of filing the application but also for other categories of goods and services that it intends to market in the future (judgment of 14/02/2012, T-33/11, 'BIGAB', para. 25; judgment of 07/06/2011, T-507/08, '16PF', para. 88).
- The fact that the owner of several national marks decides to apply for a CTM for only one and not all of them cannot be an indication of bad faith. The decision to protect a mark at both national and Community level is a choice dictated by the proprietor's marketing strategy. It is not for OHIM or the Court to interfere with this choice (judgment of 14/02/2012, T-33/11, 'BIGAB', para. 29).
- If a sign enjoys a reputation at national level and the owner applies for a CTM, the extent of the sign's reputation might justify the owner's interest in ensuring broader legal protection (judgment of 11/06/2009, C-529/07, 'Lindt Goldhase', paras 51 and 52).

3.3.3 Proof of bad faith

Good faith is presumed until proof to the contrary is adduced (judgment of 13/12/2012, T-136/11, 'Pelikan', para. 57). The invalidity applicant needs to prove that there was bad faith on the part of the CTM owner at the time of filing the CTM, for example that the CTM owner had no intention of using the CTM or that its intention was to prevent a third party from entering the market. The decisions of the Board of Appeal of 12/07/2013 in the URB cases (R 1306/2012-4, R 1309/2012-4 and R 1310/2012-4) make it clear that bad faith has to be clearly proven by the applicant.

3.3.4 Relation to other CTMR provisions

Whilst Article 8(3) CTMR is a manifestation of the principle that commercial transactions must be conducted in good faith, Article 52(1)(b) CTMR is the general expression of that principle (see page 4 et seq. of the Guidelines on Article 8(3) CTMR).

3.3.5 Extent of invalidity

When bad faith of the CTM owner is established, the whole CTM is declared invalid, even for goods and services that are unrelated to those protected by the invalidity applicant's mark. The only exception is where the applicant has directed its invalidity application against only some of the goods and services covered by the contested CTM, in which case a finding of bad faith will invalidate the CTM only for the goods and services that have been contested.

For example, in its decision R 0219/2009-1 ('GRUPPO SALINI/SALINI'), the Board of Appeal concluded that bad faith had been proven and declared the contested CTM invalid in its entirety, i.e. also for services (insurance, financial and monetary services in Class 36 and software and hardware-related services in Class 42) that were dissimilar to the invalidity applicant's building, maintenance and installation services in Class 37.

The General Court confirmed the Board of Appeal's decision and stated that a positive finding of bad faith at the time of filing the contested CTM could only lead to the invalidity of the CTM in its entirety (judgment of 11/07/2013, T-321/10, 'Gruppo Salini', para. 48).

Whereas the Court did not expand on the reasons for this conclusion, it can be safely inferred that it took the view that the protection of the general interest in business and commercial matters being conducted honestly justifies invalidating a CTM also for goods/services that are dissimilar to the invalidity applicant's ones and do not even belong to an adjacent or neighbouring market.

Therefore, it seems only logical that the invalidity, once declared, should extend to all the goods and/or services covered by the contested CTM, even those that, in a pure Article 8(1)(b) scenario, would be found to be dissimilar.

4 Relative Grounds for Invalidity

4.1 Introduction

Article 53 CTMR enables proprietors of earlier rights to apply for a declaration of invalidity of a CTM in a range of situations (grounds), which are detailed below.

- The same grounds as in opposition proceedings:
 - An earlier trade mark, within the meaning of Article 8(2) CTMR, is identical or similar to the contested CTM and covers identical or similar goods and services or is reputed (Article 53(1)(a) CTMR in conjunction with Article 8(1)(a) or (b) and Article 8(5) CTMR)
 - A trade mark has been filed without authorisation by an agent or representative of its proprietor (Article 53(1)(b) CTMR in conjunction with Article 8(3) CTMR).
 - A non-registered trade mark or other sign used in the course of trade can invalidate a CTM registration if national laws allow the proprietor of the earlier sign to prohibit the use of the CTM registration (Article 53(1)(c) CTMR in conjunction with Article 8(4) CTMR).
- An additional ground based on **another earlier right**, to the extent that EU law or national law (including rights deriving from international agreements having effect in a Member State) entitle the proprietor to prohibit the use of the contested CTM (Article 53(2) CTMR), in particular:
 - a right to a name
 - a right of personal portrayal
 - a copyright
 - an industrial property right.

These **grounds** are further developed below (Sections 4.2 and 4.3).

As in opposition proceedings, the proprietor of the contested CTM may require the invalidity applicant to submit **proof of genuine use** of its earlier trade mark. The particularities regarding the relevant period for assessing genuine use in invalidity proceedings are explained in Section 4.4.

Finally, the CTMR includes a number of provisions that can be invoked by the CTM proprietor against the invalidity application, depending on the type of earlier right invoked (e.g. whether or not it is an earlier CTM or national trade mark). These provisions are dealt with under Section 4.5.

4.2 Grounds under Article 53(1) CTMR

4.2.1 Standards to be applied

The substantive conditions for considering an earlier right referred to in Article 53(1) CTMR in conjunction with Article 8 CTMR as a relative ground for a declaration of invalidity are the same as in opposition proceedings. The practice rules in the Guidelines, Part C, Opposition, in particular Section 2, Identity and Likelihood of Confusion; Section 3, Unauthorised Filing by Agents of the TM Proprietor, Chapter 4,

Conditions of Application; Section 4, Rights under Article 8(4) CTMR; and Section 5, Trade Marks with Reputation, should be applied accordingly.

4.2.2 Points in time to be considered

4.2.2.1. For the assessment of enhanced distinctiveness or reputation

In line with opposition proceedings, in invalidity proceedings an invalidity applicant **relying on enhanced distinctiveness or reputation** must prove that its earlier right has acquired **enhanced distinctiveness or reputation** by the **filing** date of the contested CTM, taking account, where appropriate, of any priority claimed. In addition, the reputation or the enhanced distinctive character of the earlier mark must still exist when the **decision on invalidity is taken**.

In opposition proceedings, due to the short time span between the filing of the CTM application and the opposition decision, it is normally presumed that the enhanced distinctiveness or reputation of the earlier trade mark still exists at the time of the decision¹. In invalidity proceedings, however, the time span can be considerable. In this case, the invalidity applicant must show that its earlier right continues to enjoy enhanced distinctive character or reputation at the time the decision on invalidity is taken.

4.2.2.2. Application based on Article 53(1)(c) in conjunction with Article 8(4) CTMR

In the event of an application for invalidity based on Article 53(1)(c) in conjunction with Article 8(4) CTMR, the invalidity applicant must show the earlier sign's **use in the course of trade of more than local significance** by the **filing date** of the contested CTM (or the priority date if relevant). In **invalidity proceedings**, the applicant also has to prove that the sign was used in the course of trade of more than local significance at another point in time, namely **at the time of filing of the invalidity request**. This condition stems from the wording of Article 53(1)(c) CTMR, which states that a Community trade mark shall be declared invalid 'where there **is** an earlier right as referred to in Article 8(4) and the conditions set out in that paragraph are fulfilled' (decision of the Cancellation Division of 05/10/2004, No 606 C, 'ANKER', and decision R 1822/2010-2 – 'Baby Bambolina', para. 15). Once proved, this requirement is considered still to be fulfilled at the **time the decision on invalidity is taken** unless there is evidence to the contrary (e.g. a company name is invoked but the company has ceased to exist).

There are further particularities regarding **substantiation and admissibility**, which are dealt with in the Guidelines, Part D, Section 1, Cancellation Proceedings.

4.3 Grounds under Article 53(2) CTMR – Other earlier rights

A CTM is liable to be declared invalid on the basis of the rights below where use of the trade mark could be prohibited under the Community or national law governing their protection. This is **not an exhaustive list** of such earlier rights.

¹See Guidelines, Part C, Opposition, Section 5, Trade Marks with Reputation.

Article 53(2) CTMR applies only where the rights invoked are of such a nature that they are not considered typical rights to be invoked in cancellation proceedings under Article 53(1) CTMR (Cancellation Division decision of 13/12/2011, 4033 C, para. 12).

4.3.1 A right to a name/right of personal portrayal

Not all Member States protect the right to a person's name or portrayal. The exact scope of protection of the right will follow from the national law (e.g. whether the right is protected irrespective of the goods and services the contested mark covers).

The invalidity applicant will have to provide the necessary **national legislation in force** and put forward a **coherent line of argument** as to why it would succeed under the specific national law in preventing the use of the contested mark. A mere reference to the national law will not be considered sufficient: it is not for the Office to make that argument on the applicant's behalf (see, by analogy, judgment of 05/07/2011, C-263/09, 'Elio Fiorucci').

Earlier right	Contested sign	Case No
TELESIS	TELESIS	R 0134/2009-2
<p><i>Right to a name under Austrian law</i></p> <p>Under Austrian law (Section 43 AGBG), 'the person whose right to use his name has been contested or whose name is used without due [cause] to his detriment, infringing his protectable interests, can request the infringer to cease and desist and to compensate any damages. Such protection extends as well to distinctive designations of traders, even if they deviate from the civil name of that trader ... Even if Section 43 AGBG may also apply to a trader's name, the scope of protection does not go beyond the field of activity of the sign used. The remaining contested services are dissimilar to the services of the earlier right as ... they concern different branches of activity (paras 61-63)'. Thus, the requirements under Austrian law were not fulfilled and the request for invalidity based on Article 53(2)(a) CTMR in conjunction with Austrian law was rejected.</p>		

Earlier right	Contested sign	Case No
'MARQUÉS DE BALLESTAR' Nobility title (título nobiliario)		R 1288/2008-1
<p><i>Right to a name under Spanish law</i></p> <p>In Spain, noble titles are protected under Law 1/1982 as if they were persons' names. The applicant for cancellation proved that this noble title exists and that it is held by her. The Community trade mark comprises a small coat of arms and the words MARQUÉS DE BALLESTAR in large letters. The wine could not be correctly identified in any business transaction without mentioning the words MARQUÉS DE BALLESTAR. The right conferred by the CTM consists of using this in the following ways: placing it on the product container, putting the product bearing the trade mark onto the market, and using it in publicity (Article 9 CTMR). Consequently, trade mark use is use 'for publicity, commercial or similar purposes', within the meaning of Article 7(6) of Law 1/1982. Since these uses are considered by this Law as 'unlawful intromissions', the protection provided by Article 9(2) of that same Law would be admissible. This Article allows the adoption of measures to 'put an end to the unlawful intromission'. The CTM must be declared invalid because its use can be prohibited as a result of a right to a name in accordance with the Spanish legislation on protection of the right to honour, personal and family privacy and own image (paras 14 et seq.).</p>		

Earlier right	Contested sign	Case No
DEF-TEC	DEF-TEC	R 0871/2007-4
<p><i>Right to a name under German law</i></p> <p>The Board considers that 'what could eventually be protected under § 12 BGB is the name of the cancellation applicant, which is 'DEF-TEC Defense Technology GmbH', but not the sign 'DEF-TEC' which is not the cancellation applicant's name ... the registration, and eventual use as a trade mark, of the designation 'DEF-TEC' on pepper sprays cannot infringe the right to the cancellation applicant's name. ... § 12 BGB protects the names of physical persons and as there is no absolute prohibition to bear a name which is similar to another person's name, its protection is limited to cases where the right to the other person's name is denied or misappropriated ... and nothing else applies to the extended application of § 12 BGB to the names of legal persons ... The request for declaration of invalidity fails on account of all the earlier rights invoked' (para. 38 et seq.).</p>		

4.3.2 Copyright



According to Article 53(2)(c) CTMR, a Community trade mark shall be declared invalid on application to the Office where the use of such trade mark may be prohibited pursuant to another earlier right under the Community legislation or national law governing its protection, and in particular copyright.



Pursuant to Rule 37 CTMIR, the application for a declaration of invalidity must contain particulars of the right on which the application is based and particulars showing that the applicant is the proprietor of an earlier right as referred to in Article 53(2) CTMR or that it is entitled under the applicable national law to claim that right.



Although the Community legislator has harmonised certain aspects of copyright protection (see Directive 2001/29/EC of the European Parliament and of the Council of 22/05/2001 on the harmonisation of certain aspects of copyright and related rights in the information society, OJ L 167, 22/06/2001, pages 10–19), so far there is no full-scale harmonisation of the copyright laws of the Member States, nor is there a uniform Community copyright. However, all the Member States are bound by the *Berne Convention for the Protection of Literary and Artistic Works* and the *Agreement on Trade-Related Aspects of Intellectual Property Rights* ('TRIPS').

The invalidity applicant will have to provide the necessary **national legislation in force** and put forward a **cogent line of argument** as to why it would succeed under the specific national law in preventing the use of the contested mark. A mere reference to the national law will not be considered sufficient: it is not for the Office to make that argument on the applicant's behalf (see, by analogy, judgment of 05/07/2011, C-263/09 'Elio Fiorucci').

The notion of copyright protection is applicable irrespective of the goods and services the contested mark covers and merely requires a 'copying' of the protected work without a requirement that the contested mark **as a whole** has to be 'similar' to the protected work.

Earlier right	Contested sign	Case No
		R 1235/2009-1
<p><i>Copyright under Italian law</i></p> <p>The Board indicates that this ground of invalidity is relative and, therefore, only holders of earlier rights — or other parties, if allowed by the law governing those rights — are entitled to invoke it (Article 56(1)(c) CTMR). The right relied upon here is copyright. Therefore, the party entitled to act is the holder of the copyright in the flower design or another party authorised by the law governing copyright. The invalidity applicant acknowledges that ownership of the copyright in the design ‘belongs to third parties’ (in fact to one third party: Corel Corporation, the graphic design company). The invalidity applicant does not own the right it seeks to rely upon. It solely has the right to use clip art with the flower shape and use it for purely private purposes. The ground was rejected (para. 32 et seq.).</p>		

Earlier right	Contested sign	Case No
		R 1757/2007-2
<p><i>Copyright under French law</i></p> <p>‘... the mere fact that the stylization of the letter ‘G’ is ‘simple’, does not exclude its protection under French copyright law ... Indeed, for a work of the mind to be protected, it is sufficient for it to be “original” ... While it is true that the contested CTM is not an exact copy of the earlier work, it must be borne in mind that the partial reproduction and adaptation without the consent of the owner of the copyright is also prohibited. The Board considers this to be the case here. The contested CTM has taken all the essential characteristic features of the prior work: a stand-alone capital ‘G’ in straight, thick, black lines, in a perfectly square flattened shape ... the ‘G’ of the contested CTM is drawn in a thick, black line of equal width and its inner part reaches further inside, than is the case in the prior work. However, the difference in these minor details constitute minimal modifications which do not affect the overlap in the essential characteristic features of the earlier work, namely, a stand-alone capital ‘G’ with a perfectly rectangular form, a flattened shape and thick, black lines ... As the partial reproduction or adaptation of the prior work has been done without the owner’s consent, it is unlawful. Therefore, the contested decision must be annulled and the request for a declaration of invalidity ... must be upheld’ (para. 33 et seq.).</p>		



Earlier right	Contested sign	Case No
		R 1925/2011-4
<p><i>Copyright under German law</i></p> <p>‘Pursuant to § 1 of the German Copyright Act, copyright protection is granted to the ‘authors’ of ‘works of literature, science, or art’. § 2 of the Act lists various types of work considered works of art. Pursuant to §§ 16 et seq., the copyright law protects the author. Under the assumption that the claimed subject-matter constituted a ‘work’ in the sense of those provisions, the cancellation applicant failed to demonstrate and to prove who was its author, and, how the cancellation applicant (a legal person with its seat in Japan) acquired the exclusive rights from the author’ (paras. 12-13). The Board examined each of these aspects. Moreover, it describes the differences between trade mark similarity and copying for the purposes of copyright infringement. The cancellation applicant had mixed up both concepts (paras 22-24).</p>		

4.3.3 Other industrial property rights

Other industrial property rights and prior works at national or Community level, such as a Registered Community design (RCD), may be invoked.

The invalidity applicant will have to provide the necessary **national legislation in force** and put forward a **cogent line of argument** as to why it would succeed under the specific national law in preventing the use of the contested mark. A mere reference to the national law will not be considered sufficient: it is not for the Office to make that argument on the applicant's behalf (see, by analogy, judgment of 05/07/2011, C-263/09, 'Elio Fiorucci').

In the case of an RCD there is no need to prove what protection is given under the law. The Cancellation Division will apply the standards of the RCD.

Earlier right	Contested sign	Case No
 <p>(earlier RCD)</p>	 <p>(shape of a teabag)</p>	<p>R 2492/2010-2</p>
<p>'Article 19(1) Council Regulation CDR states that a registered Community design shall confer on its holder the exclusive right to use it and to prevent any third party not having his consent from using it. The aforementioned use shall cover, in particular, the making, offering, putting on the market, importing, exporting or using of a product in which the design is incorporated or to which it is applied, or stocking such a product for those purposes. According to Article 10(1) CDR the scope of the protection conferred by a Community design shall include any design which does not produce on the informed user a different overall impression. The earlier RCD and the contested CTM provoke a different overall impression. ... Furthermore, it is observed that the earlier RCD introduces additional differences, such as the presence of a remarked base that does not form part of the contested CTM. Consequently, the Board confirms the Cancellation Division finding that the rights conferred by RCD No 241 427 pursuant to Article 19(1) CDR cannot be invoked against the contested CTM' (paras. 59-64).</p>		

4.4 Non-use of the earlier mark

According to Article 57(2) and (3) CTMR, where the **earlier mark has been registered for five years or more** when the application for a declaration of invalidity is filed, the proprietor of the CTM may request that the proprietor of the earlier mark submit proof that the earlier mark has been put to genuine use in the EU in connection with the goods or services for which it is registered or that proper reasons for non-use exist.

According to Rule 40(6) in conjunction with Rule 22(3) CTMIR, the indications and evidence for submitting proof of use shall consist of indications concerning the place, time, extent and nature of use of the earlier trade mark for the goods and services for which it is registered and on which the application for a declaration of invalidity is based.

The practice rules applicable to the **substantive assessment** of proof of use of earlier rights in opposition proceedings are applicable to the assessment of proof of use in invalidity proceedings (see the Guidelines, Part C, Opposition, Section 6, Proof of Use, Chapter 2, Substantive Law). In particular, when the CTM proprietor requests proof of use of the earlier rights, the Office will examine whether, and to what extent, use has

been proved for the earlier marks, provided this is relevant for the outcome of the decision.

Finally, there is a particularity to be taken into account in the assessment of proof of use in the context of invalidity proceedings. It regards the **relevant time of use**. Pursuant to Article 57(2) CTMR in conjunction with Article 42(2) CTMR, in contrast to opposition proceedings, there are two relevant periods during which use has to be established.

- In all cases when the earlier trade mark was registered for more than five years prior to the application for invalidity: the period of five years preceding the date of **filing** of the application for a declaration of invalidity (first relevant period).
- Additionally, in cases when the earlier mark was registered for at least five years on the date on which the contested CTM application was published: the period of five years preceding the date of **publication** of the application for the contested CTM (second relevant period).

These two relevant periods do not necessarily overlap: they may totally or partially overlap or follow on from each other (with or without a gap).

4.5 Defences against an invalidity application based on relative grounds

4.5.1 Consent to registration

According to Article 53(3) CTMR, the CTM may not be declared invalid if the owner of the earlier right consents expressly to the registration of the CTM before filing the application for a declaration of invalidity.

Consent does not have to be given before the date of registration of the CTM. It is sufficient if it is given before the application for invalidity is filed. For these purposes, the Office will take into account, for instance, a contract to this effect between the parties.

Earlier right	Contested sign	Case No
SKYROCK		R 1736/2010-2
<p>The CTM proprietor argued that by virtue of the coexistence agreement, the cancellation applicant had effectively consented to the registration of the contested CTM pursuant to Article 53(3) CTMR. BoA examined the coexistence agreement and the interpretation thereof by the French courts. It concluded that the French courts construed the coexistence agreement as conferring a right on the part of the CTM proprietor to register marks, other than 'SKYROCK' and 'SKYZIN', that contain the prefix 'SKY'. 'That agreement has a worldwide scope of application and therefore applies to Community trade mark applications or registrations, such as the one in dispute in the present case' (para. 32).</p>		

Evidence of express consent must take the form of a statement (and not of conduct). The statement must come from the applicant (and not from third parties). The consent must be 'express' (and not implicit or presumed) (decision of 23/07/2009, R 1099/2008-1, para. 46)

Merely withdrawing an opposition unilaterally does not necessarily imply that the opponent consents to the registration of the CTMA (decision of 14/10/2008,

R 0946/2007-2 and R 1151/2007-2, 'VISION', para. 26). As Article 53(3) CTMR requires express consent, the withdrawal of the opposition has not been considered as consent for registration (decision of 01/12/2012, R 1883/2011-5, para. 30, appealed).

4.5.2 Earlier applications for declaration of invalidity or counterclaims

According to Article 53(4) CTMR, where the proprietor of an earlier right has previously made an application for a declaration of invalidity of a CTM or has made a counterclaim for invalidity in infringement proceedings on the basis of rights in Article 53(1) or (2) CTMR before a Community trade mark court, it may not submit a new application for a declaration of invalidity on the basis of other rights referred to in Article 53(1) or (2) CTMR that it could have invoked in the original proceedings.

Although Article 100 CTMR imposes an obligation on Community trade mark courts to notify the Office of the initiation of counterclaims for invalidity and their outcome, in practice this is not always done. A CTM proprietor wishing to rely on the defence provided for by Article 53(4) CTMR must submit evidence from the national court to support its claim.

4.5.3 Acquiescence

According to Article 54 CTMR, where the proprietor of an earlier CTM or national trade mark has acquiesced in the use of the CTM for a period of five successive years, while being aware of the use, the CTM is not liable to be declared invalid, unless registration of the later CTM was applied for in bad faith.

The aim of Article 54 CTMR is to penalise the proprietors of earlier trade marks who have acquiesced, for a period of five successive years, in the use of a later Community trade mark while being aware of such use, by excluding them from seeking a declaration of invalidity or by opposing the use **of** that trade mark, which will then therefore be able to coexist with the earlier trade mark (judgment of 28/06/2012, T-133/09 and 134/09, 'B. Antonio Basile 1952', para. 32).

The **burden of proof** is on the proprietor of the contested CTM to show that:

- the contested CTM was used in the Community (or in the Member State where the earlier trade mark is protected) during a period of at least five successive years;
- the invalidity applicant was aware of this or could reasonably be presumed to be aware of it;
- although the invalidity applicant could have stopped the use, it nevertheless remained inactive. This is not the case where there was a licence or distribution relationship between the parties, so that use by the CTM proprietor was for goods it lawfully obtained from the invalidity applicant (judgment of 22/09/2011, C-482/09, 'Budweiser', para. 44; decision of 20/07/2012, R 2230/2010-4).

All three conditions must be fulfilled. If they are, the limitation on acquiescence will apply only to the contested goods or services for which the later CTM has been used.

The period of limitation in consequence of acquiescence starts running from the time when the proprietor of the earlier trade mark **becomes aware** of the use of the later CTM. It is at this point that it has the option of not acquiescing in its use and, therefore,

opposing it or seeking a declaration of invalidity of the later trade mark (judgment of 28/06/2012, T-133/09 and 134/09, 'B. Antonio Basile 1952', para. 33).

An example of where the proprietor could reasonably be presumed to be aware of the use of the contested CTM is where both proprietors have exhibited goods or services under the respective marks at the same event.

Article 54 CTMR is not applicable when the contested CTM was filed in bad faith. This exception will only be considered if it is argued and proven by the applicant.

4.5.3.1 Examples rejecting the acquiescence claim

Earlier right	Contested sign	Case No
BASILE		T-133/09 and T-134/09 (C-381/12 P dismissed the action)
<p>The appeal applicant did not adduce 'any evidence capable of establishing when the intervener became aware of the use of the contested trade mark after its registration. It merely stated that the contested trade mark had been used for more than five years in Italy and that the intervener must have been aware of that use. Nevertheless, ... less than five years had elapsed between the date of registration of the contested trade mark and the date when the application for a declaration of invalidity was filed, as use of that mark prior to its registration is not relevant since it had not yet been registered' (para. 34).</p>		

Earlier right	Contested sign	Case No
DIABLO	DIABLO	R 1022/2011-1
<p>'In the case at hand, the contested Community trade mark was registered on 11 April 2007 and the request for invalidity was filed on 7 July 2009. Thus, the contested mark had been registered as a Community trade mark for less than five years. Given that one of the conditions provided for in Article 54(2) CTMR is not fulfilled, the Board concludes that the Cancellation Division was right in holding that the applicant has not acquiesced in the use of the CTM' (paras 25-26).</p>		

Earlier right	Contested sign	Case No
VAGUA FLOW		R 2230/2010-4 (confirmed by T-417/12)
<p>'The late evidence [filed] by the CTM proprietor shows that in 2005 'AQUA FLOW' branded products were being distributed by various companies in Spain including Hydro Sud. It is claimed that the cancellation applicant was aware of that use. The CTM proprietor furnished three invoices to third companies located in Spain: 'Hydro Sud', 'Tonocolor SL Hydro Sud' and 'H2O Problematica del Agua'. These invoices are dated 18 June 2004, 31 May 2005 and 31 July 2006 and contain headings with a representation of the mark 'AQUA FLOW'. However, all these invoices postdate May 2004. Under the assumption that the cancellation applicant had knowledge of them, or of the underlying commercial transactions, this would not be enough for the finding that there was an uninterrupted period of five years preceding the cancellation request in the meaning of Article 54(2) CTMR' (paras 21-22). Therefore, the CTM proprietor's claim of acquiescence was dismissed.</p>		

Earlier right	Contested sign	Case No
PURELL	PURELL	R 1317/2009-1
<p>'Article 54(2) CTMR requires that the contested Community trade mark be used for five successive years in Germany and that the cancellation applicants have acquiesced in this use for this period. In the present case, the arguments and materials submitted by the parties do not allow for the conclusion that the contested mark was used in Germany and that the cancellation applicants could reasonably be presumed to be aware of that use and to have acquiesced, for five successive years, in that use ... the sole elements that would suggest some connection with Germany and on which the CTM proprietor relies primarily on appeal (i.e. the figures related to the unique local distributor and the Internet excerpts examined in light of the correspondence of 2001 between the parties) are insufficient to hold that the cancellation applicants have acquiesced in the long and well-established honest use of the contested mark in Germany' (para. 47).</p>		

4.5.3.2 Examples (partially) accepting the acquiescence claim

Earlier right	Contested sign	Case No
CITYBOND	CITIBOND	3971 C R 1918/2011-5 (appeal withdrawn; the Cancellation Division decision has become final)
<p>Taking the evidence as a whole, it showed that all the conditions for acquiescence were met for some of the contested services. In particular, the exchange of letters between the parties showed that the applicant was aware of the existence of the CTM 'CITIBOND' for some of the services. Moreover, the extracts and the statutory declaration (2003) included in proceedings in the UK, and the rest of the financial information, demonstrated that the applicant was conscious of the use of the CTM 'CITIBOND' in the UK, bearing in mind that the financial market is very specific and highly specialised.</p>		

Earlier right	Contested sign	Case No
Ghibli Et al		R 1299/2007-2
<p>The cancellation applicant acknowledged that he was aware of the use of this sign, in Italy. The legal issue was whether – for the purposes of applying Article 53(2) CTMR – the cancellation applicant also had to be aware of the legal status of the sign used, namely, that it had been used as a registered CTM in Italy. In the Board's view, Article 53(2) CTMR cannot be interpreted to require the CTM proprietor to prove – in addition to the five years' concurrent use, knowingly tolerated by the proprietor of the earlier right – that the cancellation applicant also knew, for at least five years, that the later mark was protected as a CTM. What matters in this context is the objective circumstance that the sign (the use of which has been knowingly tolerated by the cancellation applicant), must have existed, for at least five years, as a CTM. In view of the evidence in the file, it was proven that when the request for a declaration of invalidity was filed, the cancellation applicant had been aware and tolerated the use of the contested CTM in Italy for more than five years, irrespective of whether or not he was aware of the fact of registration (para. 35 et seq.).</p>		

5 Res Judicata

Pursuant to Article 56(3) CTMR, in addition to the particular defences that a CTM proprietor may raise against an application for a declaration of invalidity or against a revocation application (see sections above), an invalidity or revocation application is inadmissible if an application relating to the **same subject matter and cause of action, involving the same parties** has been adjudicated on by a court in a Member State and a final decision has been taken. This is the so-called 'triple-identity' requirement.

Although Article 56(3) CTMR refers only to final decisions of national courts, the same applies, by analogy and taking into account **Articles 83 and 100(2)** CTMR, to cases where there is a final decision of the Office or the Court of Justice of the European Union on another cancellation application on the same subject and cause of action involving the same parties (decision of the Cancellation Division of 30/09/2009 in Case 3458 C, para. 10).

The defence of res judicata only applies where there is a previous **final decision on the substance** in a counterclaim or cancellation application. The bar to admissibility does not apply, for instance, when a cancellation application was withdrawn before the corresponding decision became final (decision of 12/05/2014, R 1616/2013-4, para. 13) or when the previous final decision declared the application inadmissible (e.g. because the contested CTM was not yet registered) and did not adjudicate on the substance.

(i) Same subject matter

Res judicata does not apply to a request for revocation where the previous final decision refers to another request for revocation submitted on a different date. This is because the points in time at which the circumstances leading to the revocation have to be established (lack of use, CTM becoming generic or subject to misleading use) are different and the subject matter cannot therefore be deemed to be the same (decision of the Cancellation Division of 31/01/2014 in Case 7333 C).

(ii) Same cause of action

A prior decision by the Office in **opposition proceedings** between the same parties and relating to the same mark does not preclude a later cancellation request based on the same earlier rights (judgment of 14/10/2009, T-140/08, 'TiMiKinderjoghurt', para. 36, appeal to the Court dismissed, and judgment of 23/09/2014, T-11/13, 'MEGO', para. 12), since the cause of action is different. However, a different outcome in invalidity or revocation proceedings is unlikely to arise except where one or more of the following conditions is fulfilled.

- New facts are proven (e.g. proof of use or reputation of the earlier mark, not made available during opposition proceedings).
- The manner in which key legal assessments are made has changed (e.g. with regard to the standards for assessing likelihood of confusion), for example as a result of intervening judgments of the Court of Justice of the European Union.

(iii) Same parties

The triple identity required by res judicata also means that the parties to both proceedings (the one in question and the one that led to the previous final decision) have to be the same.

***GUIDELINES FOR EXAMINATION IN THE
OFFICE FOR HARMONIZATION IN THE
INTERNAL MARKET (TRADE MARKS AND
DESIGNS) ON COMMUNITY TRADE MARKS***

PART E

REGISTER OPERATIONS

SECTION 1

CHANGES IN A REGISTRATION

Table of Contents

1	Surrender	4
1.1	General principles	4
1.2	Legal effect	4
1.3	Formal requirements	5
1.3.1	Form	5
1.3.2	Language	5
1.3.3	Fees	5
1.3.4	Necessary particulars	5
1.3.5	Partial surrender	6
1.3.6	Signature	6
1.3.7	Representation, authorisation	6
1.3.8	Requirements where a licence or other right in the Community trade mark has been registered	6
1.4	Examination	7
1.4.1	Competence	7
1.4.2	Registration or rejection	8
2	Alteration of a Trade Mark	8
2.1	General principles	8
2.2	Formal requirements	9
2.2.1	Form and language	9
2.2.2	Fees	9
2.2.3	Mandatory indications	9
2.3	Substantive conditions for alteration	10
2.3.1	Examples of acceptable alterations	10
2.3.2	Examples of unacceptable alterations	11
2.4	Publication	12
3	Changes of Name or Address	12
4	Changes in Collective Trade Mark Regulations	13
4.1	Registration of the amended regulations	14
5	Division	14
5.1	General provisions	14
5.2	Formal requirements	15
5.2.1	Form and language	15
5.2.2	Fees	15
5.2.3	Mandatory indications	15
5.3	Registration	16
5.4	New file, publication	17
6	Post-Registration Seniority Claims	18

6.1	General principles	18
6.2	Legal effect	18
6.3	Formal requirements	19
6.3.1	Form	19
6.3.2	Language	19
6.3.3	Fees	19
6.3.4	Mandatory indications	19
6.4	Examination	20
6.4.1	Substantive examination	20
6.4.2	Triple identity	21
6.4.3	Harmonised seniority information	22
6.5	Registration and publication	22
6.6	Cancellation of seniority claims	23
7	Replacement of a CTM Registration by an IR	23

1 Surrender

Article 50 CTMR
Rule 36 CTMIR

1.1 General principles

At any time after registration a Community trade mark (CTM) may be surrendered by its proprietor in respect of some or all of the goods and services. The surrender must be declared to the Office in writing. (For information on the withdrawal of Community trade mark applications, i.e. prior to registration, please see the Guidelines, Part B, Examination, Section 1, Proceedings, paragraph 5.1.)

1.2 Legal effect

Article 50(2) CTMR
Rule 36 CTMIR

Surrenders only become legally effective on the date of entry in the Register of Community Trade Marks ('the Register'). The registration procedure for the surrender may be suspended during on-going proceedings (see paragraph 1.4.1 below).

The proprietor's rights in the registered CTM, as well as those of its licensees and any other holders of rights in the mark, lapse with an *ex nunc* effect on the date of the registration of the surrender in the Register. Therefore, the surrender has no retroactive effect.

The surrender has procedural and substantive effects.

In procedural terms, when the surrender is entered in the Register, the Community trade mark ceases to exist and any proceedings involving the mark before the Office terminate.

The substantive effects of surrender vis-à-vis third parties comprise the CTM proprietor renouncing any rights arising from its mark in the future.

The declarant is bound by the declaration of surrender during its registration procedure, provided that the following circumstances are present.

- a) No revocation of the declaration reaches the Office on the same day as the receipt of the declaration of surrender. That means that if a declaration of surrender and a letter revoking that declaration reach the Office on the same day (regardless of the hour and minute of their receipt), they cancel each other out. Once it becomes effective, the declaration may not be revoked.
- b) The declaration meets all the formal requirements, in particular those identified in paragraph 1.3.8 below.

1.3 Formal requirements

1.3.1 Form

Rules 79, 79a, 80, 82 CTMIR
Decision No°EX-11-03 of the President of the Office

The proprietor must declare the surrender to the Office in writing. The general rules for communication with the Office apply (see the Guidelines, Part A, General Rules, Section 1, Means of Communication, Time Limits).

The declaration of surrender is void where it contains conditions or time limitations. For example, it may not be made under the condition that the Office takes a particular decision or, in *inter partes* proceedings, that the other party makes a procedural declaration. For instance, during cancellation proceedings the mark may not be (partially) surrendered on the condition that the cancellation applicant withdraws its cancellation action. However, this does not exclude the possibility of an agreement between the parties, or that both parties request successive actions (for example, surrender of the trade mark and withdrawal of the cancellation action) in the same letter to the Office.

1.3.2 Language

Rule 95(b) CTMIR
Article 119(2) CTMR

The declaration of surrender must be filed in one of the five languages of the Office.

1.3.3 Fees

There is no fee for a declaration of surrender.

1.3.4 Necessary particulars

Rule 36(1) CTMIR

The declaration of surrender must contain the particulars referred to in Rule 36(1) CTMIR. These are:

- the CTM registration number
- the CTM's proprietor's name and address or simply the proprietor's OHIM ID number
- where the surrender is only for some of the goods or services for which the mark is registered, either the goods and services for which the surrender is declared or an indication of the goods and services for which the mark is to remain registered or both (see below under paragraph 1.3.5 Partial surrender.).

1.3.5 Partial surrender

A CTM may be surrendered in part, that is, for some of the goods and services for which it is registered. A partial surrender only becomes effective on the date it is entered in the Register.

For a partial surrender to be accepted, the following two conditions relating to the goods and services must be met:

- a) the new wording must not constitute an extension of the list of goods and services;
- b) the partial surrender must constitute a valid description of goods and services.

For further details on acceptable restrictions, please see the Guidelines, Part B, Examination, Section 3, Classification.

1.3.6 Signature

Except where Rule 79 CTMIR allows otherwise, the declaration of surrender must be signed by the CTM proprietor or its duly appointed representative (see paragraph 1.3.7 below). If the declaration is submitted by electronic means, the indication of the sender's name is deemed to be equivalent to a signature.

If an unsigned declaration is sent to the Office, the Office will invite the party concerned to correct the irregularity within a two-month time limit. If the deficiency is not remedied within the time limit, the surrender will be rejected.

1.3.7 Representation, authorisation

As far as representation of the CTM proprietor who is declaring the surrender is concerned, the normal rules apply (see the Guidelines, Part A, General Rules, Section 5, Professional Representation).

The procedural rules applicable in certain Member States that an authorisation does not cover the right to declare the surrender of a trade mark unless expressly specified are not applicable under the CTMR.

1.3.8 Requirements where a licence or other right in the Community trade mark has been registered

Surrender cannot be registered if third parties have registered rights in the CTM (such as licensees, pledgees, etc.) without first fulfilling certain additional requirements.

Where a licence, or another right in the CTM, is entered in the Register, the following additional requirements apply.

- a) The CTM proprietor must submit sufficient proof that it has informed the licensee, pledgee, etc. of its intention to surrender.

If the proprietor proves to the Office that the licensee, pledgee, etc. has given its consent to the surrender, the surrender will be registered upon receipt of that notice.

If the CTM proprietor merely submits proof that it has informed the licensee/pledgee of its intention to surrender, the Office will inform the proprietor that the surrender will be registered three months after the date on which the Office received the evidence (Rule 36(2) CTMIR).

The Office will consider a copy of the letter from the proprietor to the licensee/pledgee as sufficient evidence, provided that there is a reasonable likelihood that the letter was actually sent and received by the licensee/pledgee. The same applies to a written statement signed by the licensee/pledgee that it has been informed. An affidavit by the proprietor is not necessary. The term 'prove' in Article 50(3) CTMR does not refer to absolute certainty but to a reasonable probability, as follows from the other language versions of the regulations (French version of Article 50(3): *justifie*, Italian *dimostre*, German *glaubhaft macht*). The documents may be in any of the 23 official languages of the European Union. However, the Office may require a translation into the language chosen for the declaration of surrender or, at the choice of the declarant, into any of the five languages of the Office.

If the proof is missing or insufficient, the Office will ask for it within a time limit of two months.

- b) Where a levy of execution is entered in the Register, the declaration of surrender must be accompanied by a declaration of consent to the surrender signed by the authority competent for the levy of execution (see the Guidelines, Part E, Register Operations, Section 3, CTMs as Objects of Property, Chapter 4, Levy of Execution).
- c) Where insolvency or similar proceedings are entered in the Register, the declaration of surrender must be requested by the liquidator (see the Guidelines, Part E, Register Operations, Section 3, CTMs as Objects of Property, Chapter 5, Insolvency).

1.4 Examination

1.4.1 Competence

The Office is competent for examining the declaration of surrender.

Where surrender (or a partial surrender covering all the goods and/or services against which the application for cancellation is directed) is declared during ongoing revocation or invalidity proceedings against the validity of the CTM that is being surrendered, the relevant department (for example, the Cancellation Division) will be informed and the Office will suspend the registration of the surrender. The Cancellation Division will invite the cancellation applicant to indicate whether it wishes to continue with the proceedings and if so, the cancellation proceedings will continue until there is a final decision on substance. After the decision on the cancellation has become final, the surrender will be registered only for the goods and/or services for which the contested CTM has not been revoked or declared invalid, if any (see judgment of 24/03/2011, C-552/09 P, 'TiMiKinderjoghurt', para. 39, decision of 22/10/2010, R 0463/2009-4 –

'MAGENTA', paras 25-27 and decision of 07/08/2013, R 2264/2012-2 – 'SHAKEY'S'). (See the Guidelines, Part D, Cancellation, Section 1, Cancellation Proceedings, paragraph 7.3).

Where the CTM is subject to a case pending before the Boards of Appeal (BoA), the competent chamber will decide on the surrender.

Where the CTM is subject to a case pending before the General Court (GC) or the Court of Justice (CJEU), the surrender must be filed at the Office (not before the GC or the CJEU). The Office will then inform the GC or the CJEU whether or not it finds the surrender acceptable and valid. However, the surrender proceedings will be suspended until the GC or the CJEU has rendered a final decision on the issue (by analogy, see judgment of 16/05/2013, T-104/12, 'VORTEX')

1.4.2 Registration or rejection

In the event of a deficiency, the Office will give the declarant two months to remedy the deficiency.

Where the deficiency which is brought to the attention of the declarant is not remedied within the time limit specified, the Office will entirely reject the request to record the surrender in the Register.

Where the Office enters the surrender in the Register, it will inform the CTM proprietor and all right holders registered for that trade mark accordingly.

When notifying the registration of a partial surrender, a copy of the new list of goods and services will be given in the confirmation letter in the language of the proceedings.

2 Alteration of a Trade Mark

2.1 General principles

Article 48 CTMR Rule 25 CTMIR

This Section of the Guidelines, and the provisions cited above, deal solely with alterations of the CTM that are requested by the proprietor of its own accord.

There is a difference between an amendment of a CTM application and an alteration of a registered CTM. The amendment of a CTM application is governed by Article 43 CTMR and Rules 13 and 26 CTMIR. The alteration of a registered CTM is governed by Article 48 CTMR, and Rules 25 and 26 CTMIR (for more information on amendments of a CTM application, see the Guidelines, Part B, Examination, Section 2, Examination of Formalities).

This Section does not apply to corrections of obvious errors by the Office in its publications or in the CTM Register; such corrections are made *ex officio*, or at the proprietor's request, pursuant to Rules 14 and 27 CTMIR (for more information, see the Guidelines, Part A, General Rules, Section 6, Revocation of Decisions and Cancellation of Entries in the Register and Correction of Errors).

The Regulations provide for the possibility of applying for an amendment of the representation of the mark (alteration of the mark) providing such alteration relates to the proprietor's name and address **and** does not substantially affect the identity of the trade mark as originally registered.

The Regulations do not provide for the possibility of altering other elements of the CTM registration.

2.2 Formal requirements

2.2.1 Form and language

Article 48(2) CTMR

The application to alter the mark, that is, the representation of the mark, must be made in writing in one of the five languages of the Office.

2.2.2 Fees

Article 2(25) CTMFR

The application is subject to a fee of EUR 200; the request is deemed not to have been filed until the fee is paid (see the Guidelines, Part A, General Rules, Section 3, Payment of Fees, Costs and Charges).

2.2.3 Mandatory indications

Rule 25(1) CTMIR

The application for alteration must contain:

- the CTM registration number
- the CTM proprietor's name and address in accordance with Rule 1(1)(b) CTMIR; if the proprietor has previously been allocated an ID number by OHIM, it is sufficient to indicate that ID number together with the proprietor's name
- an indication of the element in the representation of the mark to be altered and the altered version of the element
- a representation of the mark as altered that complies with the formal requirements laid down in Rule 3 CTMIR.

One single application for alteration may be filed for several CTM registrations, provided that both the CTM proprietor and the element to be altered are the same in each case. However, the fee has to be paid for each registration to be altered.

2.3 Substantive conditions for alteration

Article 48(2) CTMR allows the alteration of the representation of the mark only under extremely limited conditions, namely only when:



- the CTM includes the CTM proprietor's name and address, **and**
- these are the elements for which alteration is sought, **and**
- the alteration would not substantially affect the identity of the trade mark as originally registered.



Strict rules apply: where the proprietor's name or address is part of the distinctive elements of the mark, for example, part of a word mark, an alteration is excluded since the identity of the mark would be substantially affected. An exception can only be accepted for usual abbreviations relating to the legal structure of the company. An alteration of the mark is only possible if the CTM proprietor's name or address appears on a figurative mark, for example, the label of a bottle, as a subordinate element in small letters. Such elements would normally not be taken into account in determining the scope of protection or the fulfilment of the use requirement. The rationale of Article 48 CTMR is precisely to exclude any alteration of the registered CTM that could affect its scope of protection or the assessment of the use requirement, so that rights of third parties cannot be affected.

No other element of the mark may be altered, even if it is only a subordinate element in small letters of a descriptive nature, such as the indication of the percentage of alcohol on a label of a bottle of wine.

Furthermore, Article 48(2) CTMR does not allow for the alteration of the list of goods and services (see decision of 09/07/2008, R 0585/2008-2 – 'SAGA', para. 16). After registration, the only way to change the list of goods and services is through partial surrender under Article 50 CTMR (see paragraph 1.3.5 above).

2.3.1 Examples of acceptable alterations

MARK AS REGISTERED	PROPOSED ALTERATION
<p style="text-align: center;">CTM 7 389 687</p> 	

MARK AS REGISTERED	PROPOSED ALTERATION
<p>CTM 4 988 556</p> 	

2.3.2 Examples of unacceptable alterations

MARK AS REGISTERED	PROPOSED ALTERATION
<p>CTM 11 058 823</p> <p>ROTAM – INNOVATION IN POST PATENT TECHNOLOGY’</p>	<p>ROTAM – INNOVATION IN POST PATENT TECHNOLOGY</p>
<p>CTM 9 755 307</p> <p>MINADI MINADI Occhiali</p>	<p>MINADI</p>
<p>CTM 10 009 595</p> <p>CHATEAU DE LA TOUR SAINT-ANNE</p>	<p>CHATEAU DE LA TOUR SAINTE-ANNE</p>
<p>CTM 9 436 072</p> <p>SLITONE ULTRA</p>	<p>SLITONEULTRA</p>
<p>CTM 2 701 845</p> 	
<p>CTM 3 115 532</p> 	

MARK AS REGISTERED	PROPOSED ALTERATION
CTM 7 087 943 	
CTM 8 588 329 	

2.4 Publication

Where the alteration of the registration is allowable, it will be registered and published in Part C.3.4 of the Bulletin; the publication will contain a representation of the CTM as altered.

Within three months of the publication of the alteration, third parties whose rights may be affected by the alteration may challenge the registration thereof. For this procedure, the provisions on the opposition procedure apply *mutatis mutandis*.

3 Changes of Name or Address

Rules 26, 84 CTMIR

It is possible to alter the name, address or nationality of the proprietor of a registered CTM or its representative. The application to record the change must be made in one of the five languages of the Office. The alteration will be entered in the Register and published.

Pursuant to Rule 26 CTMIR, the name, including the indication of the legal form, and address of the proprietor or representative may be amended freely, provided that:

- as regards the proprietor's name, the change is not the consequence of a transfer
- as regards the representative's name, there is no substitution of one representative by another.

Pursuant to Rule 84(3) CTMIR, the indication of the nationality or the State of incorporation of a legal person may also be altered or added, provided that it is not the consequence of a transfer.

A change of the proprietor's name within the sense of Rule 26(1) CTMIR is a change that does not affect the identity of the proprietor, whereas a transfer is a change from one proprietor to another. For details and the applicable procedure in case of doubt as to whether the change falls under Article 17 CTMR, see the Guidelines, Part E, Register Operations, Section 3, CTMs as Objects of Property, Chapter 1, Transfer.

Likewise, a change of a representative's name within the sense of Rule 26(6) CTMIR is limited to a change which does not affect the identity of the appointed representative, for example, where the name changes as a result of marriage. Rule 26(6) CTMIR also applies where the name of an association of representatives changes. Such a change of name has to be distinguished from the substitution of one representative by another, which is subject to the rules governing appointment of representatives; for details, see the Guidelines, Part A, General Rules, Section 5, Professional Representation.

A change of name or address under Rule 26 CTMIR, or of nationality, may be the result of changed circumstances or of an error made when filing.

To record a change of name and address, the proprietor or its representative must submit an application to the Office. The application must contain the CTM number as well as the name and address of the proprietor (in accordance with Rule 1(1)(b) CTMIR) or of the representative (in accordance with Rule 1(1)(e) CTMIR), both as recorded in the file and as amended.

Normally no proof or evidence of the change is necessary. However, in the event of doubt, the examiner may ask for proof such as a certificate from a trade register. The application to record the change of name or address is not subject to a fee.

Legal persons can only have one official address. In the event of doubt, the examiner may ask for evidence of the legal form or the address in particular. The official name and address are also used as the address for service by default. Ideally, a proprietor should have only one address for service. A change in the proprietor's official designation or official address will be registered for all CTMs and RCDs in the name of that proprietor. A change in the official designation or address cannot be recorded just for specific portfolios of rights, contrary to the address for service. These rules apply to representatives by analogy.

4 Changes in Collective Trade Mark Regulations

Article 71 CTMR

According to Article 71 CTMR, the proprietors of Community collective marks must submit to the Office any amended regulations governing use.

The application to enter in the Register an amendment of the regulations governing the use of a collective trade mark must be made in writing in one of the five languages of the Office.

4.1 Registration of the amended regulations

Article 67(2), Articles 68 and 69 CTMR, Article 71(3), (4) CTMR, Rule 84(3)(e) CTMIR

The amendment will not be entered in the Register if the amended regulations do not satisfy the requirements of Article 67(2) CTMR or involve one of the grounds for refusal referred to in Article 68 CTMR.

Where the registration of the amendment of the regulations is accepted, it will be registered and published.

The recordal applicant will specify the part of the amended regulations to be entered in the Register, which can be:

- the applicant's name and office address
- the purpose of the association or the purpose for which the legal person governed by public law is constituted
- the bodies authorised to represent the association or the legal person
- the conditions for membership
- the persons authorised to use the mark
- where appropriate, the conditions governing use of the mark, including sanctions
- if the mark designates the geographical origin of goods or services, authorisation for any person whose goods or services originate in the geographical area concerned to become a member of the association.

Within three months of the publication of the amended regulations, third parties whose rights may be affected by the amendment may challenge the registration thereof. For this procedure, the provisions on third party observations apply *mutatis mutandis*.

5 Division

5.1 General provisions

Article 49 CTMR
Rule 25a CTMIR

A registration can be split into different parts not only as the result of a partial transfer (see the Guidelines, Part E, Register Operations, Section 3, CTMs as Objects of Property, Chapter 1, Transfer), but also on the CTM proprietor's own motion. A division of a trade mark is particularly useful in order to isolate a disputed trade mark for certain goods or services and maintain the registration for the remainder. For information on the division of CTM applications, see the Guidelines, Part B, Examination, Section 1, Proceedings.

Whereas a partial transfer is free of charge but involves a change of proprietorship, the request for division of a trade mark is subject to a fee of EUR 250 and the trade mark remains in the hands of the same proprietor. If the fee is not paid, the request is deemed not to have been filed. The request must be made in one of the five languages of the Office.

Division is not available for international registrations under the Madrid Protocol designating the EU. The Register of International Registrations is kept exclusively at WIPO. OHIM does not have the authority to divide an international registration.

5.2 Formal requirements

5.2.1 Form and language

The application to divide the CTM must be made in writing in one of the five languages of the Office.

5.2.2 Fees

Article 2(22) CTMFR

The application is subject to a fee of EUR 250; the request is deemed not to have been filed until the fee is paid (see the Guidelines, Part A, General Rules, Section 3, Payment of Fees, Costs and Charges).

5.2.3 Mandatory indications

Rule 25a CTMIR

The request must contain:

- the registration number of the CTM to be divided
- the proprietor's name and address; if the proprietor has previously been allocated an ID number by OHIM, it is sufficient to indicate that ID number together with the proprietor's name
- the list of goods and services for the divisional registration, or, if more than one new registration is to be created, for each divisional registration
- the list of those goods and services that will remain in the original CTM.

The goods and services must be distributed between the original CTM and the new CTM so that the goods and services in the original and the new CTM do not overlap. The two specifications taken together must not be broader than the original specification.

Therefore, the indications must be clear, precise and unequivocal. For example, when a CTM for goods or services in several classes is involved, and the 'split' between the old and new registration concerns whole classes, it is sufficient to indicate the respective classes for the new registration or for the remaining one.

When the application for a division indicates goods and services which are explicitly mentioned in the original list of goods and services, the Office will automatically retain the goods and services which are not mentioned in the division application for the

original CTM. For example, the original list contains goods A, B, and C and the division application relates to C; the Office will keep goods A and B in the original registration and create a new registration for C.

For the assessment of whether there is limitation or a broadening of scope of the list, the rules generally applicable in such situations apply (see the Guidelines, Part B, Examination, Section 3, Classification).

In all cases it is highly recommended to file a clear and precise list of goods and services to be divided as well as a clear and precise list of goods and services to remain in the original registration. Furthermore, the original list must be clarified. For example, if the original list related to *alcoholic beverages* and the division relates to *whisky* and *gin*, the original list must be amended by restricting it to *alcoholic beverages, except whisky and gin*.

The Office will notify the proprietor of any deficiency in this regard and will give the proprietor two months to remedy the deficiency. If the deficiency is not remedied, the declaration of division will be refused (Rule 25a(2) CTMIR).

There are also certain periods during which, for procedural economy or to safeguard third party rights, a declaration of division is not admissible. These periods are prescribed by Article 49(2) CTMR and Rule 25a(3) CTMIR and are the following.

- As long as cancellation proceedings are pending before the Office (application for revocation or declaration of invalidity), only those goods and services against which the cancellation request is not directed may be divided from the original CTM. The Office interprets Article 49(2)(a) CTMR as not only excluding a division where some of the contested goods are divided from the original CTM, with the effect that the cancellation proceedings would have to be split, but also as excluding that all the contested goods are divided from the original CTM. However, in this case, the CTM proprietor will be given the opportunity to amend the declaration of division by dividing the other goods and services from the original CTM, that is, those which are not contested in the cancellation proceedings.
- As long as proceedings are pending before the Boards of Appeal, the General Court or the European Court of Justice only those goods and services not affected by the proceedings may be divided from the original CTM due to the suspensive effect of the proceedings.
- Likewise, as long as a counterclaim for revocation or declaration of invalidity is pending before a CTM court, the same conditions apply. This covers the period starting on the day the counterclaim was lodged before the CTM court and ending on the date on which the Office mentions the CTM court's judgment in the CTM Register pursuant to Article 100(6) CTMR.

5.3 Registration

If the Office accepts the declaration of division, a new registration is created as of that date and not retroactively as from the date of the declaration.

The new registration keeps the filing date as well as any priority or seniority dates, depending on the goods and services; the seniority effect may become partial.

All requests and applications submitted and all fees paid prior to the date on which the Office receives the declaration of division are also deemed to have been made or paid for the resulting divisional registration. However, fees duly paid for the original registration will not be refunded (Article 49(6) CTMR). The practical effects of this provision can be exemplified as follows.

- Where an application for the registration of a licence was submitted and the payment of the fee for its registration was received by the Office prior to the declaration of division, the licence will be recorded in the Register of both the original and the divisional CTM if the licence covers goods and/or services in the original and divisional CTM. No further fees need to be paid.
- Where a CTM registration containing six classes is to be divided into two registrations, each containing three classes, no additional class fees for the renewal are payable as from the date on which the division is entered in the Register but instead two basic renewal fees will be payable, one for each registration.

Where the division is not accepted, the original registration remains unchanged. It does not matter whether:

- the declaration of division was deemed not to have been filed in the absence of the fee
- the declaration was refused because it failed to comply with the formal requirements (see 5.2 above).

In neither of the latter two cases will the fee be reimbursed.

Where the final decision of the Office is that the declaration of division is not acceptable for any of the above reasons, the applicant may re-apply for the declaration of division, **which will be subject to a new fee.**

5.4 New file, publication

Rule 84(2) and Rule 84(3)(w) CTMIR

A new file has to be created for the divisional registration. It must contain all the documents which were on file for the original registration, plus all the correspondence related to the declaration of division, as well as all future correspondence for the new registration.

The division will be published in the CTM Bulletin. Rule 84(3)(w) CTMIR provides that the division of the registration will be published together with the items referred to in Rule 84(2) CTMIR in respect of the divisional registration and the list of goods and services of the original registration as amended.

6 Post-Registration Seniority Claims

Article 35 CTMR Rule 28 CTMIR Communication No 2/00 of 25/02/2000 Decision No EX-03-5 of 20/01/2003 Decision No EX-05-5 of 01/06/2005

6.1 General principles

The proprietor of an earlier trade mark registered in a Member State, including a trade mark registered under international arrangements having effect in a Member State, who holds an identical CTM for goods or services which are identical with or contained within those for which the earlier trade mark has been registered, may claim for the CTM the seniority of the earlier trade mark in respect of the Member State in or for which it is registered.

Seniority may be claimed at any time after the registration of the CTM.

6.2 Legal effect

Seniority has the sole effect that where the holder of a CTM surrenders their earlier national trade mark registration or allows it to lapse, they will be deemed to continue to have the same rights as they would have had if the earlier trade mark had continued to be registered.

This means that the CTM represents a prolongation of earlier national registrations. If a proprietor claims seniority from one or more earlier registered national marks, the owner may decide not to renew the earlier national registrations but still be in the same position as if the earlier trade mark had continued to be registered in those Member States where the earlier marks were registered. The Office recommends the proprietor to wait until it receives confirmation of the acceptance of the seniority claim before allowing the national mark to lapse (see also below under paragraph 6.4.2 Triple identity).

Seniority may be claimed not only for earlier national registrations, but also for an international registration designating an EU country. However, no seniority claim is possible for an earlier CTM registration or local registrations, even if the territory is part of the European Union (e.g. Gibraltar).

6.3 Formal requirements

6.3.1 Form

Rules 79, 79a, 80, 82 CTMIR
Decision No°EX-11-03 of the President of the Office

The seniority claim must be declared to the Office in writing. The general rules for communication with the Office apply (see the Guidelines, Part A, General Rules, Section 1, Means of Communication, Time Limits).

The Office has made available to the public, free of charge, a form for the purpose of requesting the recordal of post-registration seniority claims. This form is the Recordal Application and may be downloaded from the Office's website (<http://oami.europa.eu>).

6.3.2 Language

Rule 95(b) CTMIR

The seniority claim must be filed in one of the five languages of the Office.

6.3.3 Fees

There is no fee for an application for a seniority claim.

6.3.4 Mandatory indications

Rule 28 CTMIR
Decision No EX-05-5 of 01/06/2005

The application must indicate:

- the CTM registration number
- the CTM proprietor's name and address in accordance with Rule 1(1)(b) CTMIR; if the proprietor has previously been allocated an ID number by OHIM, it is sufficient to indicate that ID number and the proprietor's name
- the Member State or Member States of the European Union in or for which the earlier mark, for which seniority is claimed, is registered
- the registration number and filing date of the relevant earlier registration(s).

Pursuant to Decision No EX-05-5 of 01/06/2005, the proprietor is not required to file a copy of the registration if the required information is available to the Office on the website of the respective national office. If the copy of the registration is not submitted, the Office will first search for the necessary information on the respective website and only if the information is not available there will it ask the proprietor for a copy. Pursuant to Article 3 of Decision No EX-03-5, the copy of the relevant registration must

consist of a copy (simple photocopies suffice) of the registration and/or renewal certificate or extract from the Register, or an extract from the relevant national Gazette, or an extract or printout from a database. Examples of extracts that are not accepted are DEMAS, MARQUESA, COMPUSERVE, THOMSON, OLIVIA, PATLINK or COMPUMARK, SAEGIS.

6.4 Examination

6.4.1 Substantive examination

Seniority may only be claimed from an earlier **registration**, not an earlier application. The date of the earlier trade mark must be before the respective dates of the CTM (filing date or, if available, the priority date).

The examiner must check both that the earlier mark was registered and that it had not lapsed at the moment the claim was made (on the duration of protection of national marks see the Guidelines, Part C, Opposition, Section 1, Procedural Matters, paragraph 4.2.3.4).

If the earlier registration had lapsed at the moment the claim was made, seniority cannot be claimed, even if the relevant national trade mark law provides for a six-month grace period for renewal. While some national legislations allow for a 'grace' period, if the renewal is not paid the mark is considered to have lapsed from the day it was due for renewal. Therefore, the seniority claim is acceptable only if the applicant shows that it has renewed the earlier registration(s).

In the context of an **enlargement** of the EU, the following details have to be borne in mind. Where a national trade mark of, or an international registration with effect in, a new Member State was registered before the seniority claim is made, **seniority may be claimed even though the priority, filing or registration date of the CTM to which the seniority claim relates predates the priority, filing or registration date of the national mark/IR with effect in the new Member State**. This is because the CTM at issue only has effect in the new Member State from the date of accession. The national trade mark/IR with effect in the new Member State for which seniority is claimed is therefore 'earlier' than the CTM within the sense of Article 35 CTMR, **provided** the national trade mark/IR with effect in the new Member State enjoys a priority, filing or registration date **prior to the accession date** (see the Guidelines, Part A, General Rules, Section 9, Enlargement, Annex 1).

Examples of acceptable seniority claims for new Member States				
CTM	Filing date	Seniority claim country	Accession date	Filing date of earlier right
2 094 860 TESTOCAPS	20/02/2001	Cyprus	01/05/2004	28/02/2001
2 417 723 PEGINTRON	19/10/2001	Hungary	01/05/2004	08/11/2001
352 039 REDIPEN	02/04/1996	Bulgaria	01/01/2007	30/04/1996
7 073 307 HydroTac	17/07/2008	Croatia	01/07/2013	13/10/2009

Explanation: In all cases, although the filing date of the CTM application is earlier than the filing date of the mark for which seniority is claimed, all the countries concerned acceded to the European Union after the filing date of the CTM application. It is from the accession date that the CTM application has protection in those Member States. Therefore, seniority can be claimed for any national marks filed prior to the date of accession.

If the claim to seniority is in order, the Office will accept it and – once the CTM application has been registered – inform the relevant central industrial property office(s) of the Member State(s) concerned (Rule 8(3) CTMIR).

6.4.2 Triple identity

A valid seniority claim requires triple identity:

- the registered mark must be identical to the Community trade mark
- the goods and services of the CTM must be identical or contained within those for which the mark is registered
- the proprietor must be the same.

(See judgment of 19/01/2012, T-103/11, ‘Justing’.)

Examination of seniority claims is limited to the formal requirements and to the identity of the marks (see Communication of the President No 2/00 of 25/02/2000).

It is up to the owner to make certain that the triple identity requirements are met. The Office will normally only examine whether the marks are identical. The identity of owner, goods and services will not be examined.

As regards the identity of the marks, word marks will generally be considered without reference to the typeface in which they are registered. In considering whether word marks are identical the Office will not object if, for example, one mark is in uppercase and the other in lowercase. The addition or subtraction of a single letter in a word mark is sufficient for marks not to be considered identical. As far as figurative marks are concerned, the General Court has held that

Even although the objectives of Article 8(1)(a) and of Article 34 of that regulation [CTMR] are not the same, it is a condition for the application of both of them that the marks at issue must be identical ...

...

It must be stated at the outset that the fact that a mark is registered in colour or, on the contrary, does not designate any specific colour cannot be regarded as a negligible element in the eyes of a consumer. The impression left by a mark is different according to whether that mark is in colour or does not designate any specific colour.

(See judgment of 20/02/2013, T-378/11 ‘Medinet’, paras 40 and 52).

For full details of Office practice in relation to identity between trade marks filed in black and white and/or greyscale as compared to those filed in colour for the purposes of seniority claims, please see the Guidelines, Part B, Examination, Section 2 Formalities, paragraph 14.2.1, in relation to priority claims, which applies by analogy.

If the claim to seniority does not satisfy the formal requirements or if the marks are not identical, the Office will notify the proprietor and give it two months to remedy the deficiency or submit observations.

If the deficiency is not remedied, the Office will inform the proprietor that the right to claim seniority has been rejected.

For examples of acceptable and unacceptable seniority claims see the Guidelines, Part B, Examination, Section 2, Formalities, paragraph 16.6.

6.4.3 Harmonised seniority information

In order to properly manage seniorities, all seniority entries in the system need to have the same format as that used in the databases of the national offices.

To enhance harmonisation between OHIM and participating IP offices, a list with the required format for seniorities has been established. This list provides a description of the format/formats used in each of the national offices, insofar as this has been determined.

Therefore, when examining seniority claims, examiners must verify that the format of the seniority in the Office's system corresponds to the format used at national level.

6.5 Registration and publication

Rule 84(3)(f) CTMR

If the claim to seniority is in order, the Office will register it and inform the relevant central industrial property office(s) of the Member State(s) concerned (Rule 8(3) CTMIR).

The seniority claim will be published in the CTM Bulletin.

The publication will contain the following data:

- the CTM registration number
- the seniority claim details: country, registration number, registration date, filing date, date of priority
- the date and number of the entry of the seniority claim
- the date the entry is published in the CTM Bulletin.

Rule 84(3)(f) CTMIR provides that the seniority claim will be registered together with the items referred to in Rule 84(2).

6.6 Cancellation of seniority claims

The CTM proprietor may at any time request the cancellation of the seniority claim from the Register of its own motion.

Seniority claims may also be cancelled by a decision of a national court (see Article 14 Directive 2008/95/EC).

The cancellation of the seniority claim will be published in the CTM Bulletin. Rule 84(3)(r) CTMIR provides that the cancellation of the seniority will be registered together with the items referred to in Rule 84(2).

7 Replacement of a CTM Registration by an IR

Article 157 CTMR
Rule 84(2) CTMIR
Article 4 bis MP
Rule 21 Common Regulations under the Madrid Agreement and Protocol (CR)

In accordance with Article 4 bis of the Madrid Agreement and the Protocol, the holder of an international registration designating the European Union (IR) may request the Office to take note in its Register that a CTM registration is replaced by a corresponding IR. The holder's rights in the EU will be deemed to start from the date of the earlier CTM registration. Therefore, the Office will enter in the Register that a CTM has been replaced by a designation of the EU through an IR and that entry will be published in the CTM Bulletin.

For more information on replacement, see the Guidelines, Part M, International Marks.

***GUIDELINES FOR EXAMINATION IN THE
OFFICE FOR HARMONIZATION IN THE
INTERNAL MARKET (TRADE MARKS AND
DESIGNS) ON COMMUNITY TRADE MARKS***

PART E

REGISTER OPERATIONS

SECTION 3

CTMs AS OBJECTS OF PROPERTY

CHAPTER 1

TRANSFER

Table of Contents

1	Introduction.....	4
1.1	Transfers.....	5
1.1.1	Assignment.....	5
1.1.2	Inheritance.....	5
1.1.3	Merger.....	5
1.1.4	Applicable Law.....	5
1.2	Application to record a transfer.....	6
2	Transfers vs Changes of Name.....	6
2.1	Erroneous application to record a change of name.....	7
2.2	Erroneous application to record a transfer.....	8
3	Formal and Substantive Requirements of an Application to Record a Transfer.....	8
3.1	Languages.....	8
3.2	Application filed for more than one mark.....	9
3.3	Parties to the proceedings.....	10
3.4	Formal requirements.....	10
3.4.1	Indication of the registration number.....	10
3.4.2	Particulars of the new proprietor.....	10
3.4.3	Name and address of the representative.....	11
3.4.4	Signatures.....	12
3.5	Proof of transfer.....	12
3.6	Substantive requirements.....	14
3.7	Procedure to remedy deficiencies.....	14
4	Partial Transfers.....	14
4.1	Rules on the distribution of the lists of goods and services.....	15
4.2	Objections.....	16
4.3	Creation of a new CTM application or registration.....	16
5	Transfer During the Course of Other Proceedings and Fees Issues ..	17
5.1	Specific issues of partial transfers.....	17
5.2	Transfer and <i>inter partes</i> proceedings.....	19
6	Entry in the Register, Notification and Publication.....	19
6.1	Entry in the Register.....	19
6.2	Notification.....	19
6.3	Publication.....	20

7	Transfers for Registered Community Designs	21
7.1	Rights of prior use for an RCD	21
7.2	Fees	22
8	Transfers for International Trade Marks	22

1 Introduction

Articles 1(2), Article 17(1) and Article 24 CTMR
Article 28 CDR
Article 23 CDIR

A transfer is the change in ownership of the property rights in a Community trade mark (CTM) or CTM application from one entity to another. CTM and CTM applications may be transferred from the current proprietor to a new proprietor, primarily by way of assignment or legal succession. The transfer may be limited to some of the goods or services for which the mark is registered or applied for (partial transfer). In contrast to a licence or conversion, a transfer of a CTM cannot affect the unitary character of the CTM. Therefore, a CTM cannot be 'partially' transferred for *some* territories or Member States.

The provisions in the CDR and CDIR dealing with the transfer of designs are almost identical to the equivalent provisions of the CTMR and CTMIR, respectively. Therefore, the following applies *mutatis mutandis* to Community designs, with the few exceptions and particularities laid down in paragraph 7 below.

Article 16, Article 17(5), (6), (8), Article 24 and Article 87 CTMR
Rule 31(8), Rule 84(3)(g) CTMIR

Upon request, transfers of registered CTMs are entered in the Register and transfers of CTM applications are noted in the files.

The rules on registering transfers and on legal effects of transfers apply both to CTMs and to CTM applications. The major difference is that the Regulations stipulate that when a CTM application is transferred, the transfer will be recorded in the file of the application rather than in the Register. However, in practice, changes in the ownership of a CTM application or a CTM are recorded in the same database. While these Guidelines generally make no distinction between the transfer of CTMs and CTM applications, special references will be included where the treatment of CTM applications differs from that of CTMs.

According to Article 17 CTMR, registering a transfer is not a condition for its validity. However, if a transfer is not registered by the Office, the entitlement to act remains with the registered proprietor, meaning, *inter alia*, that the new proprietor will not receive communications from the Office, in particular during *inter partes* proceedings or the notification of the renewal term of the mark. Furthermore, according to Article 16 CTMR, in all aspects of the CTM as an object of property that are not further defined by provisions of the CTMR, the proprietor's address defines the applicable subsidiary national law. For all these reasons, it is important to register a transfer at the Office to ensure that entitlement to CTMs and applications is clear.

1.1 Transfers

Article 17(1), (2) CTMR

A transfer of a CTM involves two aspects, namely the validity of the transfer between the parties and the impact of a transfer on proceedings before the Office, such impact being triggered only after the entry of the transfer in the Register (or the files) (see paragraph 1.2 below).

As concerns the validity of the transfer between the parties, the CTMR allows a CTM to be transferred independently of any transfer of the undertaking to which it belongs (see also judgment of 30/03/2006, C-259/04, 'Elizabeth Emanuel', paras 45 and 48).

1.1.1 Assignment

Article 17(3) CTMR

When a transfer is made by an assignment, except where the assignment is the result of a court decision, the former is only valid where the assignment is made in writing and is signed by both parties. This formal requirement for the validity of the transfer of a CTM is applicable irrespective of whether, under the national law governing transfers of (national) trade marks, an assignment is valid even without observing a particular form, such as the need for the transfer to be in writing and have the signatures of both parties.

1.1.2 Inheritance

When the proprietor of a CTM or CTM application dies, the heirs will become proprietors of the registration or application by way of individual or universal succession. This is also covered by the rules on transfers.

1.1.3 Merger

Similarly, a universal succession exists when there is a merger between two companies that leads to the formation of a new company or an acquisition by one company taking over another. Where the whole of the undertaking to which the mark belongs is transferred, there is a presumption that the transfer includes the CTM unless, in accordance with the law governing the transfer, an agreement to the contrary was made or unless circumstances clearly dictate otherwise.

1.1.4 Applicable Law

Article 16 CTMR

Unless provided otherwise by the CTMR, transfers are subject to the national law of a Member State determined by Article 16 CTMR. The national law declared applicable in

that provision is the national law in general and, therefore, also includes private international law, which in turn may refer to the law of another State.

1.2 Application to record a transfer

Article 17(5)-(8), CTMR
Rule 31 CTMIR

A transfer becomes relevant in proceedings before the Office if an application to record a transfer has been made and the transfer has been entered in the Register or, for CTM applications, recorded in the CTM application file.

Article 17(7) CTMR

However, in the period between the date when the Office receives the application to record a transfer and the date of registering the transfer, the new proprietor may already make submissions to the Office with a view to observing time limits. If, for example, a party has applied to register the transfer of a CTM application for which the Office has raised objections on absolute grounds, the new proprietor may reply to the objections (see paragraph 5 below).

This part of the Guidelines covers proceedings relating to the recordal of transfers. In the course of the examination of an application for recordal of a transfer, the Office will only examine whether sufficient evidence of the transfer has been submitted. The Office will not examine whether the transfer itself is valid.

2 Transfers vs Changes of Name

Rule 26 CTMIR

A transfer must be distinguished from a change of name of the proprietor.

An application for the change of name of a proprietor of a CTM registration or application is dealt with in separate proceedings. More information on changes of name can be found in the Guidelines, Part B, Examination, Section 2, Formalities, paragraph 7.3, Change of name/address.

Rule 26(1) CTMIR

In particular, no transfer is involved when a natural person changes their name due to marriage, or following an official procedure for changing a name, or when a pseudonym is used instead of the civil name, etc. In all these cases, the identity of the proprietor is not affected.

Where the name or the corporate status of a legal person changes, the criterion for distinguishing a transfer from a mere change of name is whether or not the identity of the legal person remains the same (in which case it will be registered as a change of name) (see decision of 06/09/2010, R 1232/2010-4 – ‘Cartier’, paras 12-14). In other

words, where there is no termination of the legal entity (e.g. in the event of a merger by acquisition, where one company is completely absorbed by the other and ceases to exist) and no start-up of a new legal entity (e.g. following the merger of two companies leading to the creation of a new legal entity), there is only a change in the formal corporate organisation that already existed, and not in the actual identity itself. Therefore, the change will be registered as a change of name, where necessary.

For example, if a CTM is in the name of Company A and as the result of a *merger* this company is absorbed by Company B, there is a transfer of assets from Company A to Company B.

Likewise, during a *division* of Company A into two separate entities, one being the original Company A and the other being a new Company B, if the CTM in the name of Company A becomes the property of Company B, there is a transfer of assets.

Normally, there is no transfer if the company registration number in the national register of companies remains the same.

Likewise, there is in principle the prima facie presumption that there is a transfer of assets if there is a change of country (see, however, decision of 24/10/2013, R 546/2012-1 - 'LOVE et al').

If the Office has any doubt about the applicable national law governing the legal person concerned, it may require appropriate information from the person applying to register the change of name.

Therefore, unless it is ruled to the contrary under the national law concerned, the change of company type, provided that it is not accompanied by a transfer of assets carried out by means of a merger or an acquisition, will be treated as a change of name and not as a transfer.

On the other hand, if the change of company type is the result of a merger, a division or a transfer of assets, depending on which company absorbs or is separated from the other or on which company transfers which assets to the other, this may be a case of transfer.

2.1 Erroneous application to record a change of name

Article 133(1) CTMR Rule 26(1), (5) and (7) CTMIR
--

When an application is made to record a change of name, but the evidence shows that what is involved is actually a transfer for a CTM or CTM application, the Office informs the recordal applicant accordingly and invites it to file an application to record a transfer, which is free of charge. Such a transfer is, however, subject to the payment of a fee when related to the transfer of a Design (see paragraph 7 below). The communication sets a time limit, in general, of two months starting from the date of its notification. If the recordal applicant agrees or does not submit evidence to the contrary and files the corresponding application to record a transfer, the transfer will be recorded. If the recordal applicant does not modify its request, that is to say if it insists on recording the change as a change of name, or if it does not respond, the application

to record a change of name will be rejected. The party concerned may file an appeal against this decision. (See Decision 2009-1 of 16 June 2009 of the Presidium of the Boards of Appeal regarding Instructions to Parties in Proceedings before the Boards of Appeal).

A new application to record the transfer may be filed at any time.

2.2 Erroneous application to record a transfer

Rule 31(1), (6) CTMIR

When an application is made to record a transfer, but what is involved is actually a change of name for a CTM or CTM application, the Office informs the recordal applicant accordingly and invites it to give its consent to record the indications concerning the proprietor in the files kept by the Office or in the Register as a change of name. That communication sets a time limit, in general, of two months starting from the date of its notification. If the recordal applicant agrees, the change of name will be recorded. If the recordal applicant does not agree, that is to say if it insists on recording the change as a transfer, or if it does not respond, the application to record a transfer will be rejected.

3 Formal and Substantive Requirements of an Application to Record a Transfer

The Office strongly recommends that the online Recordal Application Form be used when applying to record a transfer. The form is free of charge and can be downloaded from the Office's web site (<http://www.oami.europa.eu>).

Since the entry into force of Regulation No 1042/05, which amended the CTMFR, there is no need to pay a fee to register a transfer.

3.1 Languages

The application for registration of a transfer must be filed:

Rule 95(a), (b) and Rule 96(1) CTMIR

- when it relates to a CTM application, in the first or the second language indicated in the CTM application;
- when it relates to a registered CTM, in one of the languages of the Office.

When the application relates to more than one CTM application, the recordal applicant must select a language for the application that is common to all the CTMs concerned. If there is no common language, separate applications for transfer must be filed.

When the application relates to at least one CTM registration, the recordal applicant must select one of the five languages of the Office.

Rule 76(3) CTMIR

When expressly required by the Office, authorisations may be filed in any official language of the European Union.

Rule 96(2) CTMIR

Any supporting documents may be filed in any official language of the European Union. This applies to any document submitted as proof of the transfer such as a countersigned Transfer Document or a Transfer Certificate, a deed of assignment or an extract from a trade register or a declaration agreeing to record the successor in title as the new proprietor.

Rule 98 CTMIR

When the supporting documents are not submitted in either an official language of the European Union or in the language of the proceedings, the Office may require a translation into the language of the proceedings or, at the choice of the recordal applicant, into any language of the Office. The Office will set a time limit of two months from the date of notification of the respective communication. If the translation is not submitted within the time limit, the document will not be taken into account and will be deemed not to have been submitted.

3.2 Application filed for more than one mark

Rule 31(7) CTMIR

Provided that both the original proprietor and the new one are the same in each case, then the recordal applicant can file a single application to record a transfer for several CTMs or CTM applications. This has the advantages that the various references only have to be given once and that only one decision needs to be taken.

Separate applications are necessary when the original proprietor and the new one are not strictly identical for each mark. This is the case, for example, where there is one successor in title for the first mark and there are multiple successors in title for another mark, even if the successor in title for the first mark is among the successors in title for the other mark. It is immaterial whether the representative is the same in each case.

When a single application is filed in such cases, the Office will issue a deficiency letter. The recordal applicant may overcome the objection either by limiting the application to those CTMs or CTM applications for which there is but one and the same original proprietor and one and the same new proprietor, or by declaring its agreement that its application should be dealt with in two or more different proceedings. Otherwise, the application will be rejected in its entirety. The party concerned may file an appeal against this decision.

3.3 Parties to the proceedings

Article 17(5) CTMR
Rule 31(5) CTMIR

The application to record a transfer may be filed by the original proprietor(s) (the CTM owner(s) as appearing in the Register or the CTM applicant(s) as appearing in the CTM application file) or by the new proprietor(s) (the 'successor in title', i.e. the person(s) who will appear as the proprietor(s) when the transfer is recorded).

The Office will usually communicate with the recordal applicant(s). In cases of doubt, the Office may require clarification from all the parties.

3.4 Formal requirements

Rule 1(1)(b), Rule 31(1), (2), Rule 79 CTMIR

An application to record a transfer must contain:

- the registration or application number of the CTM registration or application;
- the new proprietor's particulars;
- where the new proprietor appoints a representative, the representative's name and business address;
- the signature(s) of the person(s) requesting the recordal;
- proof of the transfer as set out in paragraph 3.5 below.

For additional requirements in cases of a partial transfer, see paragraph 4.

3.4.1 Indication of the registration number

Rule 31(1)(a) CTMIR

The registration number of the trade mark must be indicated.

3.4.2 Particulars of the new proprietor

Rules 1(1)(b), 31(1)(b) CTMIR

The particulars of the new proprietor that have to be indicated are the name, address and nationality in the case of a physical person. In the case of a legal entity, the recordal applicant shall indicate the official designation and must include the legal form of the entity, which may be abbreviated in a customary manner (for example, S.L., S.A, Ltd., PLC, etc.). Both natural persons and legal entities must indicate the State in which they are domiciled or have their seat or an establishment. **The Office strongly recommends indicating the State of Incorporation for US companies, where applicable, in order to differentiate clearly between different owners in its database.** These particulars correspond to the indications required in respect of an

applicant for a new CTM application. However, where the Office has already attributed an ID number to the new proprietor, indicating that number together with the name of the new proprietor is sufficient.

The form made available by the Office also requests an indication of the original proprietor's name. This indication will facilitate both the Office's and the parties' handling of the file.

3.4.3 Name and address of the representative

Rule 77 CTMIR
Article 93(1) CTMR
Rule 76(1), (2), (4) CTMIR

Applications to record a transfer may be filed and signed by representatives on behalf of the CTM proprietor or the new proprietor.

When the new proprietor appoints a representative, who signs the application, either the Office or, in the context of *inter partes* proceedings, the other party to the proceedings may request an authorisation. In this event, if the representative does not submit an authorisation, the proceedings will continue as if no representative had been appointed.

When the original proprietor's representative is also appointed as the new proprietor's representative, the representative may sign the application on behalf of both the original proprietor and the new one. The representative may also be called upon to file an authorisation signed by the new proprietor.

Articles 92(3), 93(1) CTMR

The foregoing applies not only to representatives within the meaning of Article 93 CTMR (legal practitioners and professional representatives whose names are entered on the list maintained by the Office), but also to any employee acting on behalf of the employer or, under the conditions of Article 92(3) CTMR, on behalf of a legal person (company) that has economic connections with the employer.

Rule 77, Rule 83(1)(h) CTMIR

A general authorisation in the form made available by the Office will be considered sufficient for granting authorisation to file and sign applications for registration of transfers.

An individual authorisation will be checked to see that it does not exclude the authority to apply for a registration of a transfer.

Article 92(2) CTMR

When the recordal applicant is the new proprietor and that new proprietor does not have either its domicile or its principal place of business or a real and effective

industrial or commercial establishment in the Community, for the purposes of the procedure to register the transfer it must be represented by a person entitled to represent third parties before the Office (legal practitioner or professional representative whose name is entered on the list maintained by the Office). For details of who may represent, see the Guidelines, Part A, General Rules, Section 5, Professional Representation.

3.4.4 Signatures

Rule 31(1)(d), Rule 31(5), Rule 79 CTMIR

The requirements concerning the person entitled to file the application and the signature must be seen in conjunction with the requirement to submit proof of the transfer. The principle is that the signatures of the original proprietor or proprietors and the new proprietor or proprietors must appear together or separately on the application or in an accompanying document. In the case of co-ownership, all co-owners must sign or appoint a common representative.

Rule 31(5)(a) CTMIR

When the original proprietor and the new proprietor both sign the application, this is sufficient and no additional proof of the transfer is necessary.

Rule 31(5)(b) CTMIR

When the new proprietor is the recordal applicant and where the application is accompanied by a declaration signed by the original proprietor that it agrees to the recording of the successor in title as the new proprietor, this is also sufficient and no additional proof is necessary.

When the original proprietor's representative is also appointed as the new proprietor's representative, the representative may sign the application on behalf of both the original proprietor and the new one, and no additional proof is necessary. However, when the representative signing on behalf of both the original and the new proprietor is not the representative on file (i.e. in an application simultaneously appointing the representative and transferring the CTM), the Office will contact the recordal applicant to request evidence of the transfer (authorisation signed by the original proprietor, proof of transfer, confirmation of the transfer by the original owner or its representative on file).

3.5 Proof of transfer

Article 17(2), (3) CTMR
Rules 31(1)(d), (5)(a)-(c), 83(1)(d) CTMIR

A transfer may be registered only when it is proved by documents duly establishing the transfer, such as a copy of the deed of transfer. However, as already highlighted above, filing a copy of the deed of transfer is not necessary:

- when the new proprietor or its representative submits the application to record the transfer on its own and when the application is accompanied by a written declaration signed by the original proprietor (or its representative) that it agrees to the recordal of the transfer; or
- when the application to record the transfer is signed by both the original proprietor (or its representative) and by the new proprietor (or its representative); or
- when the application to record the transfer is accompanied by a completed transfer (recordal) form or document signed by both the original proprietor (or its representative) and by the new proprietor (or its representative).

Parties to the proceedings may also use the forms established under the Trademark Law Treaty available on WIPO's web site (<http://www.wipo.int/treaties/en/ip/tlt/forms.html>). These forms are the Transfer Document – a document conceived as constituting the transfer (assignment) itself – and the Transfer Certificate – a document in which the parties to a transfer declare that a transfer has taken place. Either of these documents, duly completed, constitutes sufficient proof of transfer.

However, other means of proof are not excluded. Therefore, the agreement (deed) itself or any other document proving the transfer may be submitted.

When the mark has been subject to multiple successive transfers and/or changes of the owner's name and these have not been previously recorded in the register, it is sufficient to submit the chain of evidence showing the events leading to the relationship between the old proprietor and the new proprietor without the need to file separate individual recordal applications for each change.

When the transfer of the mark is the consequence of the transfer of the whole of the undertaking of the original proprietor, and unless proof is provided as indicated above, the document showing the transfer or assignment of the whole undertaking must be submitted.

When the transfer is due to a merger or another universal succession, the original proprietor will not be available to sign the application. In these cases, the application must be accompanied by supporting documents that prove the merger or universal succession, such as extracts from the trade register, etc. The Office may abstain from requiring additional proof where the facts are already known to the Office, for example in parallel proceedings.

When the transfer of the mark is a consequence of a right in rem, levy of execution or insolvency proceedings, the original proprietor will not be able to sign the application. In these cases, the application must be accompanied by a final court judgment transferring the ownership of the mark to the beneficiary.

Supporting documents need not be legalised, nor is it necessary to submit the original of a document. Original documents become part of the file and, therefore, cannot be returned to the person who submitted them. Simple photocopies are sufficient.

If the Office has reason to doubt the accuracy or veracity of the document, it may require additional proof.

The Office will examine the documents only to the extent that they actually prove what is indicated in the application, namely the identity of the marks concerned and the identity of the parties, and whether a transfer is involved. The Office does not consider or rule on contractual or legal questions arising under national law (see judgment of 09/09/2011, T-83/09 - 'Craic', para. 27). If doubts arise, it is the national courts that deal with the legality of the transfer itself.

3.6 Substantive requirements

Article 17(4) CTMR

The Office will not register the transfer where it is clear from the transfer documents that because of the transfer the Community trade mark is likely to mislead the public concerning the nature, quality or geographical origin of the goods or services for which it is registered unless the new proprietor agrees to limit registration of the Community trade mark to goods or services for which it is not likely to be misleading.

For more information on Office practice in relation to Article 7(1)(g) CTMR, see Part B, Section 4, Absolute Grounds for Refusal.

3.7 Procedure to remedy deficiencies

Article 17(7) CTMR
Rules 31(6), 67(1) CTMIR

Where any of the deficiencies outlined above are noted, the Office will invite the recordal applicant to remedy the deficiency within a time limit of two months, starting from the date of the notification. The notification will be addressed to the person who filed the application to record the transfer or, where that person has appointed a representative, to the representative. The Office will not automatically inform the other party to the transfer, unless this is appropriate under the circumstances.

When the recordal applicant fails to remedy the deficiency or to submit the necessary additional proof, or where it is unable to convince the Office that the objections are not well-founded, the Office will reject the application. The party concerned may file an appeal against this decision.

4 Partial Transfers

Article 17(1) CTMR
Rule 32 CTMIR

A partial transfer concerns only some of the goods and services in the CTM or CTM application. It involves the distribution of the original list of goods and services between the remaining CTM registration or application and a new one. When partial transfers are involved, the Office uses particular terminology to identify the marks. At the beginning of the proceedings there is the 'original' mark. This is the mark for which a

partial transfer has been applied for. After the registration of the transfer, there are two marks: one is a mark that now has fewer goods and services, and is called the 'remaining' mark, and one is a 'new' mark that has some of the goods and services from the original mark. The 'remaining' mark retains the CTM number of the 'original' mark while the 'new' mark has a new CTM number.

Transfer cannot affect the unitary character of the CTM. Therefore, a CTM cannot be 'partially' transferred for *some* territories.

When there are doubts as to whether the transfer is partial or not, the Office will inform the transfer recordal applicant and invite it to make the necessary clarifications.

Partial transfers may also be involved when the transfer application concerns more than one CTM or CTM application. The following rules apply for each CTM or CTM application included in the transfer application.

4.1 Rules on the distribution of the lists of goods and services

Article 43 CTMR Rule 2, Rule 32(1) CTMIR

In the application to record a partial transfer, the goods and services to which the partial transfer relates must be indicated (the list of goods and services for the 'new' registration). The goods and services must be distributed between the original CTM or CTM application and a new CTM or CTM application so that the goods and services in the original CTM or CTM application and the new one do not overlap. The two specifications taken together must not be broader than the original specification.

Therefore, the indications must be clear, precise and unequivocal. For example, when a CTM for goods or services in several classes is involved, and the 'split' between the old and new registration concerns whole classes, it is sufficient to indicate the respective classes for the new registration or for the remaining one.

When the application for a partial transfer indicates goods and services that are explicitly mentioned in the original list of goods and services, the Office will automatically retain the goods and services that are not mentioned in the transfer application for the original CTM or CTM application. For example, the original list contains goods A, B and C, and the transfer application relates to C; the Office will keep goods A and B in the original registration and create a new registration for C.

In accordance with Communication No 2/12 of the President of the Office of 20/06/2012, CTMs filed prior to the 21/06/2012 claiming a particular class heading are considered to cover all the goods and services of the alphabetical list of that class in the edition of the Nice Classification in force at the time when the filing was made (see Communication No 2/12, paras V and VI).

When the application for a partial transfer indicates goods or services that are not expressly mentioned in the original list but fall under the literal meaning of a general indication contained therein, this will be acceptable provided that the list is not broadened. For the assessment of whether there is limitation or a broadening of scope

of the list, the rules generally applicable in such situations apply (see the Guidelines, Part B, Examination, Section 3, Classification).

However, marks filed on or after 21/06/2012 claiming only the general indications of a particular class heading will be considered to cover the literal meaning of that class heading and may only be partially transferred accordingly (see Communication No 2/12 paras VII and VIII).

Marks filed after 21/06/2012 claiming the general indications of a particular class heading plus the alphabetical list will be considered to cover the literal meaning of that class heading plus the alphabetical list of goods and services concerned of that class in the edition of the Nice Classification in force at the time when the filing was made and may only be partially transferred accordingly (see Communication No 2/12 paras VII and VIII).

In all cases it is highly recommended to file a clear and precise list of goods and services to be transferred as well as a clear and precise list of goods and services to remain in the original registration. Furthermore, the original list must be clarified. For example, if the original list related to 'alcoholic beverages' and the transfer relates to 'whisky' and 'gin', the original list must be amended by restricting it to 'alcoholic beverages, except whisky and gin'.

4.2 Objections

Rules 31(6), 32(3) CTMIR

When the application does not comply with the rules explained above, the Office will invite the recordal applicant to remedy the deficiency. If the deficiencies are not remedied, the Office will reject the application. The party concerned may file an appeal against this decision.

When the exchange of communications leads to a list of goods and services for the remaining registration that is different from the list filed in the CTM application, the Office will communicate not only with the new proprietor, if it is the party requesting the registration of the partial transfer, but also with the original proprietor, who remains the person who may dispose of the list of goods and services of the original registration. The Office will make any change to the original list of goods and services subject to the agreement of the original proprietor. If the agreement is not submitted within the time limit fixed by the Office, the application to record a transfer will be rejected. The party concerned may file an appeal against this decision.

4.3 Creation of a new CTM application or registration

Article 88 CTMR
Rule 32(4), Rules 88, 89 CTMIR

A partial transfer leads to the creation of a new CTM application or registration. For this ensuing CTM application or registration, the Office will establish a separate file, which will consist of a complete copy of the electronic file of the original CTM application or

registration, the application for registration of a transfer, and all the correspondence related to the transfer application. The ensuing CTM application or registration will be given a new file number. It will have the same filing date and, where applicable, priority date as the original CTM application or registration. If the partial transfer relates to a CTM application, the ensuing CTM application is subject to the provisions for inspection of files in Article 88 CTMR.

As far as the original CTM application or registration is concerned, the Office will include in its files a copy of the application to record a transfer, but will generally not include copies of the further correspondence relating to that application.

5 Transfer During the Course of Other Proceedings and Fees Issues

Article 17(6), (7) CTMR

Without prejudice to the right to act from the time when the application for registration of a transfer is received by the Office where time limits are involved, the new proprietor will automatically become party to any proceedings involving the mark in question from the time the transfer is registered.

The filing of an application to record a transfer has no effect on time limits already running or set by the Office, including time limits for the payment of fees. New time limits for payment will not be set. From the date of registration of the transfer, the new proprietor becomes liable to pay any fees due.

Therefore, during the period between filing the application to record a transfer and the Office's confirmation of its actual entry in the Register or in the file, it is important that the original proprietor and the new proprietor actively collaborate in communicating time limits and correspondence received during *inter partes* proceedings.

5.1 Specific issues of partial transfers

Rule 32(5) CTMIR

In cases of partial transfers, the ensuing CTM or CTM application will be at the same procedural stage as the original (remaining) CTM or CTM application. Any time limit still pending for the original CTM or CTM application will be deemed to be pending for both the remaining CTM or application and the new one. After the registration of the transfer the Office will treat each CTM or CTM application separately and will decide on them separately.

When a CTM or CTM application is subject to the payment of fees and these fees have been paid by the original proprietor, the new proprietor will not be liable to pay any additional fees with regard to the new CTM or CTM application. The relevant date is the entry date of the transfer in the register or in the files; therefore, when the fee for the original pending CTM or CTM application is paid after filing an application to record a transfer but before the recordal of the transfer itself, no additional fees are due.

Article 26(2) CTMR
Rule 4, Rule 9(3), (5) CTMIR
Article 2 (2), (4) CTMFR

When the partial transfer involves a CTM application and class fees have not yet been paid or not been paid in full, the Office will proceed to record the transfer in the files of the remaining CTM application and to create a new CTM application as described above.

Where the CTM application originally related to more than three classes and, thus, would require the payment of additional class fees, the examiner will deal with such cases after recording the transfer in the files and creating a new CTM application, as described below.

When additional class fees were paid prior to recording the transfer but no additional class fees would be due because the remaining CTM application now relates to three or fewer classes, no reimbursement will be made because the fees were paid correctly at the time of payment.

In all other cases, the examiner will treat the remaining CTM application and the new one separately, but without requesting a further basic fee to be paid for the new application. Class fees for the remaining CTM application and for the new one will be determined pursuant to the situation existing after the registration of the transfer. For example, when the original application had seven classes and after the transfer the remaining application has three while the new application has four, no additional class fees are due for the remaining application, while one additional class fee must be paid for the new application. When some of the goods and services of a particular class are transferred and others are not, that class becomes payable for both the remaining application and the new one. When a time limit to pay additional class fees has already been set but not yet expired, it will be set aside by the Office to allow the determination to be made on the basis of the situation after the registration of the transfer.

Article 47(1), (3), (4) CTMR
Rule 30(2), (4) CTMIR

When the application to record a partial transfer relates to a CTM registration that is due for renewal, that is, within six months prior to the expiry of the original registration and up to six months after that expiry, the Office will proceed to record the transfer and deal with the renewal and renewal fees as described below.

When no renewal request has been filed and no fees have been paid prior to the recording of the transfer, the general rules including the rules relating to payment of fees are applicable both to the remaining CTM registration and to the new one (separate requests, separate payment of fees, as necessary).

When a renewal request has been filed prior to the registration of the transfer, that request is also valid for the new CTM. However, while the original proprietor remains a party to the renewal proceedings for the remaining CTM, the new proprietor automatically becomes party to the renewal proceedings for the new registration.

In these situations, when a renewal request has been filed but the relevant fees have not been paid prior to the registration of the transfer, the fees to be paid are determined

pursuant to the situation after the registration of the transfer. This means that both the proprietor of the remaining CTM and the proprietor of the new CTM must pay the basic renewal fee and any class fees.

When not only a renewal request has been filed prior to the registration of the transfer but also all the applicable renewal fees have been paid prior to this date, no additional renewal fees are due after the registration of the transfer. Furthermore, no reimbursement is made of any class fees already paid.

5.2 Transfer and *inter partes* proceedings

When an application to record a transfer is filed during *inter partes* proceedings, several different situations can arise. For earlier CTM registrations or applications on which the opposition/cancellation is based, the new proprietor can only become party to the proceedings (or file observations) once the application to record the transfer has reached the Office. The basic principle is that the new proprietor substitutes the original proprietor in the proceedings. The practice of the Office when dealing with transfers in opposition is described in the Guidelines, Part C, Opposition, Section 1, Procedural Matters, paragraph 6.5, Change of parties.

6 Entry in the Register, Notification and Publication

6.1 Entry in the Register

Article 17(5) CTMR Rule 31(8), Rule 84(3)(g) CTMIR

When the application to record a transfer fulfils all requirements, if it concerns a registered CTM, the transfer will be entered in the Register, while if it concerns a CTM application, the Office will record the transfer in the corresponding file.

The entry in the Register will contain the following data:

- the registration date of the transfer,
- the new proprietor's name and address,
- the name and address of the new proprietor's representative, if any.

For partial transfers, the entry will also contain the following data:

- a reference to the number of the original registration and the number of the new registration,
- the list of goods and services remaining in the original registration, and
- the list of goods and services of the new registration.

6.2 Notification

The Office will notify the recordal applicant of the recordal of the transfer.

If the application for recordal of a transfer is related to at least one CTM application, the notification will contain the appropriate reference to the relevant recording of the transfer in the files kept by the Office.

As regards notifying the other party, there is a distinction between total transfers and partial transfers.

Article 17(5) CTMR
Rule 84(5) CTMIR

In cases of a total transfer, the notification will be sent to the party who submitted the application to register the transfer, that is to say, to the recordal applicant.

There will be no information to the other party:

- when the original proprietor's representative is also the new proprietor's appointed representative (in such a case the representative will receive one communication on behalf of both parties); or
- when the original proprietor has ceased to exist (death, merger).

In all other cases, the other party will be informed of the outcome of the procedure, that is, the registration of the transfer. The other party will not receive information during the course of the proceedings unless serious doubts arise concerning the legality of the application to record the transfer or the transfer itself.

Rule 32(3), (4) CTMIR

In cases of a partial transfer, both the proprietor of the remaining CTM and the proprietor of the new CTM must receive notification, because necessarily two CTM applications or registrations are concerned. Therefore, a separate notification will be sent to the new applicant for each CTM application that has been transferred partially. In the case of a partial transfer of a CTM registration, the Office will notify the new proprietor for each registration, containing, as appropriate, indications concerning the payment of renewal fees. A separate notification will be issued to the proprietor of the remaining CTM registration.

Furthermore, where in the case of a partial transfer the list of goods and services that are to remain in the original CTM application or registration needs to be clarified or amended, such clarification or amendment requires the agreement of the proprietor of the remaining CTM application or registration (see paragraph 4.2 above).

6.3 Publication

Article 17(5) CTMR
Rule 84(3)(g), Rule 85(2) CTMIR

For CTM registrations, the Office publishes the entry in the Register of transfers in Part C of the Community Trade Marks Bulletin.

Article 39 CTMR
Rule 12, Rule 31(8) CTMIR

When the application to record a transfer relates to a CTM application that has been published pursuant to Article 39 CTMR and Rule 12 CTMIR, the publication of the registration of the mark and the entry in the Register will mention the new proprietor from the outset. The publication of the registration will contain a reference to the earlier publication.

Article 39 CTMR
Rule 12 CTMIR

When the transfer relates to a CTM application that has not been published, the publication pursuant to Article 39 CTMR and Rule 12 CTMIR will contain the name of the new proprietor without any indication that the application has been transferred. This also applies when the transfer of an unpublished CTM application is a partial transfer.

7 Transfers for Registered Community Designs

Article 1(3), Articles 27, 28, 33, 34, Article 107(2)(f) CDR
Article 23, Article 61(2), Articles 68(1)(c), 69(2)(i) CDIR
Annex Nos 16, 17 CDFR

The legal provisions contained in the CDR, CDIR and CDFR for transfers correspond to the respective provisions in the CTMR, CTMIR and CTMFR.

Therefore, both the legal principles and the procedure for recording trade mark transfers apply *mutatis mutandis* to Community designs.

There are only a few exceptions and specificities, which are detailed below.

7.1 Rights of prior use for an RCD

Article 22(4) CDR

The right of prior use for an RCD cannot be transferred except where the third person, who owned the right before the filing or priority date of the application for an RCD, is a business, along with that part of the business in the course of which the act was done or the preparations were made.

7.2 Fees

Annex Nos 16, 17 CDFR

The fee of EUR 200 for recording a transfer applies per design and not per multiple application. The same is true for the ceiling of EUR 1 000 if multiple requests are submitted.

Example 1: Out of a multiple application for 10 designs, 6 designs are transferred to the same successor in title. The fee is EUR 1 000 provided either that only one application to record these 6 transfers is filed or that several applications to record transfers are filed on the same day.

Example 2: Out of a multiple application for 10 designs, 5 designs are transferred to the same successor in title. The transfer refers also to another design not contained in that multiple application. The fee is EUR 1 000 provided that:

- only one application to record these 6 transfers is filed or several requests are filed on the same day, and
- the holder of the Community design and the successor in title is the same in all 6 cases.

8 Transfers for International Trade Marks

The Madrid System allows for the 'change of ownership' of an international registration. All applications to record a change in ownership should be submitted on form MM5 either directly to the International Bureau by the holder on record or to the national Office of the holder on record or to the national Office of the new proprietor (transferee). The application to record a transfer cannot be filed directly with the International Bureau by the new proprietor. OHIM's own Recordal Application form should not be used.

Detailed information on changes in ownership can be found in paras B.II.60.01-67.02 of the Guide to the International Registration of Marks under the Madrid Agreement and the Madrid Protocol (www.wipo.int/madrid/en/guide/).

**GUIDELINES FOR EXAMINATION IN THE
OFFICE FOR HARMONIZATION IN THE
INTERNAL MARKET (TRADE MARKS AND
DESIGNS) ON COMMUNITY TRADE MARKS**

PART E

REGISTER OPERATIONS

SECTION 3

CTMs AS OBJECTS OF PROPERTY

CHAPTER 2

LICENCES

Table of Contents

1	Introduction.....	4
1.1	Licence contracts.....	4
1.2	Applicable Law	4
1.3	Advantages of the registration of a licence.....	5
2	Registration of a Licence for a CTM or CTMA.....	6
2.1	Form, requests for more than one licence.....	6
2.2	Languages	6
2.3	Fees	7
2.4	Applicants and mandatory content of the application.....	7
2.4.1	Applicants	7
2.4.2	Mandatory indications concerning the licenced CTM and the licensee	7
2.4.3	Requirements concerning the person who makes the request – Signature, proof of the licence, representation.....	8
2.4.4	Representation	10
2.5	Optional contents of the request.....	11
2.6	Examination of the request for registration.....	12
2.6.1	Fees.....	12
2.6.2	Examination of the mandatory formalities	12
2.6.3	Examination of optional elements	13
2.7	Registration procedure and publications	14
3	Cancellation or Modification of a Licence for a CTM or a CTMA.....	15
3.1	Competence, languages, presentation of the request.....	16
3.2	Person making the request.....	16
3.2.1	Cancellation of a licence.....	16
3.2.2	Modification of a licence	17
3.3	Contents of the request	17
3.4	Fees	18
3.4.1	Cancellation of a licence.....	18
3.4.2	Modification of a licence	18
3.5	Examination of the request.....	18
3.5.1	Fees.....	18
3.5.2	Examination by the Office.....	18
3.6	Registration and publication	19
4	Transfer of a Licence for a CTM or CTMA	19
4.1	Definition of the transfer of a licence.....	19
4.2	Applicable rules.....	20
5	Registration of Licences for Registered Community Designs	20

5.1	Registered Community designs	20
5.2	Multiple applications for registered Community designs.....	21
6	Registration of Licences for International Trade Marks.....	21

1 Introduction

Articles 22, 23, 24 CTMR Articles 27, 32, 33 CDR

Registered Community trade marks (CTMs), as well as Community trade mark applications (CTMAs), may be the subject of licensing contracts (licences).

Registered Community designs (RCDs), as well as applications for a registered Community design, may be the subject of licences.

Paragraphs 1 to 4 below deal with trade mark licences concerning CTMs and CTMAs. The provisions in the CDR and CDIR dealing with design licences are almost identical to the equivalent provisions of the CTMR and CTMIR respectively. Therefore, the following applies *mutatis mutandis* to Community designs. Exceptions and specificities to Community designs are detailed in paragraph 5 below. Exceptions and specificities to international trade marks are laid down under paragraph 6 below.

1.1 Licence contracts

A trade mark licence is a contract by virtue of which the proprietor or applicant, (hereinafter referred to as the “proprietor”) of a trade mark (the licensor), whilst retaining his proprietorship, authorises a third person (the licensee) to use the trade mark in the course of trade, under the terms and conditions set out in the contract.

A licence refers to a situation where the rights of the licensee in the CTM arise from a contractual relationship with the proprietor. The proprietor’s consent to, or tolerance of, a third party using the trade mark does not amount to a licence.

1.2 Applicable Law

Article 16 CTMR

The CTMR does not have the competence to establish unified and complete provisions applicable to licences for CTMs or CTMAs. Rather, Article 16 CTMR refers to the law of a Member State, as far as the acquisition, validity and effects of the CTM as an object of property are concerned. To this end, a licence for a CTM is, in its entirety and for the whole territory of the European Union, assimilated to a licence for a trade mark registered in the Member State in which the CTM proprietor or applicant has its seat or its domicile. If the proprietor does not have a seat or domicile in a Member State, it will be dealt with as a licence for a trade mark registered in the Member State in which the proprietor has an establishment. If the proprietor does not have an establishment in a Member State, it will be dealt with as a licence for a trade mark registered in Spain.

This, however, applies only to the extent that Articles 17 to 24 CTMR do not provide otherwise.

Article 16 CTMR is limited to the effects of a licence as an object of property and does not extend to contract law. Article 16 CTMR does not govern the applicable law or the

validity of a licensing contract, which means that the freedom of the contracting parties to submit the licensing contract to a given national law is not affected by the CTMR.

1.3 Advantages of the registration of a licence

Articles 22(5), 23(1), (2), 50(3) CTMR

It is not compulsory to request an entry in the Register when there is a licence agreement. Moreover, when a party to proceedings before the Office has to prove use of a Community trade mark, if such use has been made by a licensee, it is not necessary for the licence to have been entered in the Register for that use to be deemed to be use with the proprietor's consent pursuant to Article 15(2) CTMR.. However, such a registration has particular advantages.

- a) In view of the provision of Article 23(1) CTMR, vis-à-vis third parties who might have acquired, or have entered in the Register, rights in the trade mark which are incompatible with the registered licence, the licensee may avail itself of the rights conferred by this licence only:
- if the licence was entered in the CTM Register, or
 - in the absence of registration of the licence, if the third party had acquired such rights after the date of any legal acts such as referred to in Articles 17, 19 and 22 CTMR (such as a transfer, a right in rem or a previous licence) knowing of the existence of the licence.
- b) In the case where a licence for a CTM is entered in the Register, the surrender or partial surrender of that mark by its proprietor will only be entered in the Register if the proprietor establishes that it has informed the licensee of its intention to surrender.

The holder of a licence which is registered has, therefore, the right to be informed in advance by the proprietor of the trade mark of its intention to surrender the trade mark.

- c) In the case where a licence for a Community trade mark is entered in the Register, the Office will notify the licensee at least six months before the expiry of the registration that the registration is approaching expiry. The Office will also notify the licensee of any loss of rights and of the expiry of the registration, where applicable.
- d) Registering licences and their modification and/or cancellation is important for maintaining the veracity of the Register, particularly in the event of *inter partes* proceedings.

2 Registration of a Licence for a CTM or CTMA

Article 22(5) CTMR
Rules 33, 34, Rule 84(3)(j) CTMIR

Both CTMAs and CTMs may be the subject of the registration of a licence.

The application for registration of a licence must comply with the following conditions.

2.1 Form, requests for more than one licence

Rules 83(1)(e), 95(a) and (b) CTMIR

It is strongly recommended that the request for registration of a licence for a CTM be submitted on the Office's Recordal Application form. This form is available free of charge in the official languages of the European Union. It can be downloaded from OHIM's website.

Any language version of this form may be used, provided that it is completed in one of the languages referred to in paragraph 2.2 below. This concerns, in particular, the list of goods and services and/or the territory.

Rules 31(7), 33(1) CTMIR

A single request for the registration of a licence in respect of two or more registered CTMs or CTMAs may be made only if the respective registered proprietor and the licensee are the same and the contracts have the same conditions, limitations and terms in each case (see paragraph 2.5 below).

2.2 Languages

Rule 95(a) CTMIR

The application for the registration of a licence for a CTM application may be made in the first or second language of the CTMA.

Rule 95(b) CTMIR

The application for the registration of a licence for a registered CTM must be made in one of the five languages of the Office, namely, English, French, German, Italian or Spanish.

2.3 Fees

Article 162(2)(c), (d) CTMR
Rule 33(1), (4) CTMIR
Article 2(23) CTMFR

The application for the registration of a licence is considered not to have been made until the fee is paid. The amount of this fee is EUR 200 for each CTM for which the registration of a licence is requested.

However, where several registrations of licences have been requested in one single request and the respective registered proprietor and the licensee are the same and the contractual terms are the same in all cases, the fee is limited to a maximum of EUR 1 000.

The same maximum amount applies where several registrations of licences are applied for at the same time, provided that they could have been filed in one single request and where the respective registered proprietor and the licensee are the same in all cases. Furthermore, the contractual terms must be the same. For example, an exclusive licence and a non-exclusive licence cannot be filed in the same request, even if they are between the same parties.

Once the corresponding fee is paid, the fee will not be reimbursed if the application for registration of the licence is refused or withdrawn.

2.4 Applicants and mandatory content of the application

2.4.1 Applicants

Article 22(5) CTMR

The registration of a licence may be requested at the Office by:

- a) the proprietor(s) of the CTM, or
- b) the proprietor(s) of the CTM jointly with the licensee(s), or
- c) the licensee(s).

The formal conditions with which the request must comply depend on who is making the request. It is recommended that the first or the second of these options be used, since these allow for a speedier and smoother treatment of the request for registration of the licence.

2.4.2 Mandatory indications concerning the licenced CTM and the licensee

Rule 31, Rule 33(1) CTMIR

The request for registration of a licence must contain the following information:

Rule 31(1)(a), Rule 33(1) CTMIR

- a) the registration number of the CTM concerned. If the request relates to several CTMs, each of the numbers must be indicated.

Rules 1(1)(b), 31(1)(b), Rule 33(1) CTMIR

- b) the licensee's name, address and nationality and the State in which it is domiciled or has its seat or an establishment.

Rule 1(1)(e), Rules 31(2), 33(1) CTMIR

- c) if the licensee designates a representative, the representative's name and ID number allocated by the Office should be indicated. If the representative has not yet been assigned an ID number, the business address must be indicated.

2.4.3 Requirements concerning the person who makes the request – Signature, proof of the licence, representation

Rule 79, Rule 82(3) CTMIR

The requirements concerning signature, proof of the licence and representation vary depending on the person who makes the request. Where the requirement of a signature is referred to, in electronic communications, the indication of the sender's name shall be deemed to be equivalent to the signature.

2.4.3.1 Request made by the CTM proprietor alone

Rule 1(1)(b), Rule 33(1) CTMIR

When a request is made by the CTM proprietor alone, it must be signed by the CTM proprietor. In the case of co-ownership, all co-owners must sign or appoint a common representative.

No proof of the licence is necessary.

The Office will not inform the licensee that the registration of the licence has been requested. It will, however, inform the licensee when the licence is recorded in the Register.

Where the licensee files a statement with the Office in which it opposes the registration of the licence, the Office will transmit the statement to the CTM proprietor for information purposes only. The Office will not take any further action on the statement but will register the licence. Following the registration of the licence, any licensee who disagrees with the registration of the licence may use the procedure for requesting the cancellation or amendment of the licence (see paragraph 3 below).

The Office will not take into account whether or not the parties, although having agreed on a licence contract, have agreed to register it at the Office. Any dispute on whether or not and in what manner the licence shall be registered is a matter that must be resolved among the parties concerned under the rules of the relevant national law (Article 16 CTMR).

2.4.3.2 Request made jointly by the CTM proprietor and the licensee

When the request is made jointly by the CTM proprietor and its licensee, it must be signed both by the CTM proprietor and the licensee. In the case of co-ownership, all co-owners must sign or appoint a common representative.

In this case, the signature of both parties constitutes proof of the licence.

Where there is a formal deficiency regarding the signature of the licensee or regarding the representative, the request will still be accepted as long as it would have also been acceptable if it had been presented by the CTM proprietor alone.

The same applies where there is a deficiency regarding the signature of the CTM proprietor or regarding its representative but where the request would have been acceptable if it had been presented by the licensee alone.

2.4.3.3 Request made by the licensee alone

The request may also be made by the licensee alone. In this case, it must be signed by the licensee.

In addition, proof of the licence must be submitted.

2.4.3.4 Proof of the licence

There is sufficient proof of the licence if the request for registration of the licence is accompanied by any of the following evidence.

- A declaration that the CTM proprietor agrees to the registration of the licence, signed by the CTM proprietor or its representative.

In accordance with Rule 31(5)(a) CTMIR, it is also considered sufficient proof if the request for registration of the licence is signed by both parties. This case has already been dealt with in paragraph 2.4.3.2 above.

- The licence agreement, or an extract therefrom, indicating the parties and the CTM being licensed and bearing their signatures.

It suffices if the licence agreement is filed. In many instances, the parties to the licence agreement will not wish to disclose all the details, which may contain confidential information on the licence royalties or other terms and conditions of the licence. In these cases, it suffices if only a part or an extract of the licence agreement is submitted, as long as it contains the identification of the persons who are parties to the licence agreement, the fact that the CTM in question is the

subject of a licence and the signatures of both parties. All other elements may be omitted or blacked out.

- An uncertified statement of licence using the complete WIPO Model International Form for the Request for Recordal of a License (found in the annex to the Joint Recommendation concerning trade mark licenses adopted by The Assembly of the Paris Union and the General Assembly of WIPO on 25/09-03/10/2000). The form must be signed by both the CTM proprietor, or its representative, and the licensee, or its representative. It can be found at:

http://www.wipo.int/export/sites/www/about-ip/en/development_iplaw/pdf/pub835a.pdf.

It suffices if an uncertified statement of licence on the WIPO model form is filed.

Original documents become part of the file and, therefore, cannot be returned to the person who submitted them. Simple photocopies are sufficient. The original or photocopy does not need to be authenticated or legalised.

Rule 95(a), (b), Rule 96(2) CTMIR

The evidence of the licence must be:

- a) in the language of the Office which has become the language of the proceedings for the registration of the licence, see paragraph 2.1 above;
- b) in any official language of the European Union other than the language of the proceedings; in this case the Office may require a translation of the document into a language of the Office to be filed within a period specified by the Office.

Where the supporting documents are not submitted in either an official language of the European Union or in the language of the proceedings, the Office may require a translation into the language of the proceedings or, at the choice of the party requesting the registration of the licence, into any language of the Office. The Office will fix a time limit of two months from the date of notification of that communication. If the translation is not submitted within that time limit, the document will not be taken into account and will be deemed not to have been submitted.

2.4.4 Representation

Articles 92(2), 93(1) CTMR

The general rules on representation apply (see the Guidelines, Part A, General Rules, Section 5, Professional Representation).

Where the recordal applicant has no domicile or principal place of business or a real and effective industrial or commercial establishment inside the European Union and has made the request alone, failure to fulfil the requirement of representation will lead to the request not being processed. The recordal applicant will be notified in the form of an information letter and any fees paid will be refunded. The recordal applicant is then free to submit a new request.

2.5 Optional contents of the request

Rule 34 CTMIR

Depending on the nature of the licence, the request for registration may contain the request to register the licence together with other indications, namely those referred to under paragraphs a) to e) below. These indications may be individual or in any combination, for one licence (e.g. an exclusive licence limited in time) or for several licences (e.g. one exclusive licence for A as regards Member State X and another for B as regards Member State Y). They are entered in the Register by the Office only if the request for registration of the licence itself clearly requests that they be registered. Without such an explicit request, the Office will not enter in the Register any indications contained in the licence agreement that are submitted, for example, as evidence of the licence.

However, if one or more of these indications are requested to be entered in the Register, the following details must be indicated.

Rule 34(1)(c), (2) CTMIR

- a) Where registration of a licence limited to only some of the goods or services is requested, the goods or services for which the licence has been granted must be indicated.

Rule 34(1)(d), (2) CTMIR

- b) Where the request is to register the licence as a territorially limited licence, the request must indicate the part of the European Union for which the licence has been granted. A part of the European Union may consist of one or several Member States or one or several administrative districts in a Member State.

Article 22(1) CTMR Rule 34(1)(a) CTMIR

- c) Where registration of an exclusive licence is sought, a statement to this effect must be made in the request for registration.

Rule 34(1)(e) CTMIR

- d) Where the registration of a licence granted for a limited period of time is requested, the expiry date of the licence must be specified. In addition, the date of the commencement of the licence may be indicated.

Rule 34(1)(b) CTMIR

- e) Where the licence is granted by a licensee whose licence is already entered in the Register of CTMs, the request for registration may indicate that it is for a sub-licence. Sub-licences cannot be recorded without first recording the parent licence.

2.6 Examination of the request for registration

2.6.1 Fees

Rule 33(2) CTMIR

Where the required fee has not been received, the Office will notify the recordal applicant that the request is deemed not to have been filed because the relevant fee has not been paid. However, a new request may be submitted at any time providing the correct fee is paid from the outset.

2.6.2 Examination of the mandatory formalities

Rule 33(3) CTMIR

The Office will check whether the request for registration of the licence complies with the formal conditions mentioned in paragraph 2.4 above (indication of the CTM number(s), the required information concerning the licensee, the representative of the licensee where applicable).

The validity of the licence agreement will not be examined.

Article 93(1) CTMR Rules 33, 76, 77 CTMIR

The Office will check whether the request for registration of the licence has been duly signed. Where the request is signed by the licensee's representative, an authorisation may be required by the Office or, in the context of *inter partes* proceedings, by the other party to those proceedings. In this event, if no authorisation is submitted, the proceedings will continue as if no representative had been appointed. Where the request for registration of the licence is signed by the proprietor's representative who has already been designated as the representative for the CTM in question, the requirements relating to signature and authorisations are fulfilled.

Articles 92(2), 93(1) CTMR

The examination will include whether the recordal applicant (i.e. the CTM proprietor or the licensee) is obliged to be represented before the Office (see paragraph 2.4.4 above).

Rule 33(3) CTMIR

The Office will inform the recordal applicant in writing of any deficiencies in the application. If the deficiencies are not remedied within the time limit fixed in that communication, which will normally be two months following the date of the notification, the Office will reject the request for registration of the licence. The party concerned may file an appeal against this decision. (See Decision 2009-1 of 16 June 2009 of the

Presidium of the Boards of Appeal regarding Instructions to Parties in Proceedings before the Boards of Appeal).

Where the request has been made jointly by the CTM proprietor and the licensee, the Office will communicate with the CTM proprietor and send a copy to the licensee.

Where the licensee has also made and signed the request, it will not be allowed to contest the existence or scope of the licence.

Where the request for registration of the licence is filed by the CTM proprietor alone, the Office will not inform the licensee of the recordal request. The examination of proof of the licence will be done *ex officio*. The Office will disregard any statements or allegations of the licensee regarding the existence or scope of the licence or its registration; the licensee cannot oppose the registration of a licence.

Rule 33(3) CTMIR

If the request is filed by the licensee on the basis of a copy of the licence contract, and where the Office has reasonable doubts as to the veracity of the documents, it will write to the licensee inviting it to remove those doubts. The licensee will then have the burden of proving that the licence exists, that is, it has to convince the Office of the veracity of the documents and their contents. In such a case, the Office may, within the scope of its *ex officio* power of examination (Article 76(1) CTMR), invite the CTM proprietor to submit observations. If the proprietor claims that the documents are falsified, this will be enough for the Office to reject the registration of a licence unless the licensee produces a final Court order from an E U Member State in its favour. Where the doubts cannot be removed, the registration of the licence will be refused. In such a case, the procedure always remains *ex parte* even though the CTM proprietor is heard; it is not a party to the proceedings.

2.6.3 Examination of optional elements

Rule 34 CTMIR

Where it is requested that the licence be registered as one of the following:

- an exclusive licence,
- a temporary licence,
- a territorially limited licence,
- a licence limited to certain goods or services, or
- a sub-licence,

the Office will examine whether the particulars mentioned in paragraph 2.4 above are indicated.

Rule 34(1), (2) CTMIR

As concerns the indication 'exclusive licence', the Office will only accept this term and will not accept any other wordings. If 'exclusive licence' is not expressly indicated, the Office will consider the licence to be non-exclusive.

Where the request for the registration indicates that it is for a licence limited to certain goods or services covered by the CTM, the Office will check whether the goods and services are properly grouped and are actually covered by the CTM.

Rule 34(1)(b) CTMIR

As concerns a sub-licence, the Office will check whether it has been granted by a licensee whose licence is already entered in the Register. The Office will refuse the registration of a sub-licence when the main licence has not been entered in the Register. However, the Office will not check the validity of the request for the registration of a sub-licence as an exclusive licence when the main licence is not an exclusive licence nor will it examine whether the main licence contract excludes granting sub-licences.

It is up to the licensor to pay attention not to conclude and to register incompatible contracts and to cancel or modify records that are no longer valid. For example, if an exclusive licence has been registered without limitation as to the goods and the territory, and the registration of another exclusive licence is requested, the Office will register that second licence, even though both licences seem incompatible at first sight. It is to be assumed that the second licence contract is compatible with the first licence contract either from the very beginning (and the recordal is simply not precise as to the territory or the goods) or following a change in the contractual situation which was not communicated to the Register for Community trade marks.

Parties are, however, encouraged to update all register information regularly and swiftly by means of the cancellation or modification of existing licences (see paragraph 3 below).

Article 22(1) CTMR
Rules 33(3), 34(CTMIR

If the particulars mentioned in paragraph 2.5 are missing, the Office will invite the recordal applicant for registration of the licence to submit the supplementary information. If the recordal applicant does not reply to that communication, the Office will not take into account the abovementioned indications and will register the licence without mentioning them. The recordal applicant will be notified of this by an appealable decision.

2.7 Registration procedure and publications

Rule 33(4) CTMIR

As concerns CTMAs, the licence will be mentioned in the files kept by the Office for the Community trade mark application concerned.

Rule 84(3)(j), Rule 85(2) CTMIR

When the mark is registered, the licence will be published in the Community Trade Marks Bulletin and mentioned in the Community Trade Marks Register.

Rule 84(5) CTMIR

The Office will notify both parties of the entry of the licence in the files kept by the Office. Where both parties have named a common representative, this representative will be notified.

Article 22(5) CTMR
Rule 84(3)(j), Rule 85(2) CTMIR

As concerns CTMs, the Office will enter the licence in the Community Trade Marks Register and publish it in the Community Trade Marks Bulletin.

Where applicable, the entry in the Register will mention that the licence is:

- an exclusive licence,
- a temporary licence,
- a territorially limited licence,
- a sub-licence, or
- a licence limited to certain goods or services covered by the CTM.

Only these bare facts will be mentioned. The following details will not be published:

- the period of validity of a temporary licence,
- the territory covered by a territorially limited contract,
- the goods and services covered by a partial licence.

Access to this information may be obtained through inspection of files (see the Guidelines, Part E, Register Operations, Section 5, Inspection of Files).

Licences are published in part C.4. of the Bulletin.

Rule 84(5) CTMIR

The Office will inform the recordal applicant of the registration of the licence. When the request for registration of the licence was filed by the licensee, the Office will also inform the CTM proprietor of the registration.

3 Cancellation or Modification of a Licence for a CTM or a CTMA

Rule 35(1) CTMIR

The registration of a licence will be cancelled or modified on the request of an interested party, that is, the applicant or proprietor of the CTM or the registered licensee.

The Office will refuse the cancellation, transfer and/or modification of a licence or a sub-licence when the main licence has not been entered in the Register.

3.1 Competence, languages, presentation of the request

Article 133 CTMR
Rule 35(3), (6), (7) CTMIR

Paragraphs 2.1 and 2.2 above are applicable.

It is strongly recommended that the request for cancellation of a licence be presented on the Recordal Application form. This form is available free of charge in the official languages of the European Union. It can be downloaded from OHIM's website. Parties to the proceedings may also use the WIPO Model International Form No 1, Request for Amendment/Cancellation of a Licence, which can be downloaded at http://www.wipo.int/export/sites/www/about-ip/en/development_iplaw/pdf/pub835a.pdf, or a form with a similar content and format.

3.2 Person making the request

Rule 35(1) CTMIR

The request for the cancellation or modification of the registration of a licence may be filed by:

- a) the applicant or proprietor of the CTM and the licensee jointly,
- b) the applicant or proprietor of the CTM, or
- c) the registered licensee.

3.2.1 Cancellation of a licence

Rule 35(4) CTMIR

In the case of a joint request filed by the CTM applicant or proprietor and the licensee, or of a request filed by the licensee, no proof for the cancellation of the licence is required since this implies a statement from the licensee that it consents to the cancellation of the registration of the licence. When the request for cancellation is filed by the CTM applicant or proprietor, alone, the request must be accompanied by evidence establishing that the registered licence no longer exists or by a declaration from the licensee to the effect that it consents to the cancellation.

Where the registered licensee makes the request for cancellation alone, the CTM applicant or proprietor will not be informed of this request. Any observations filed by the proprietor will be forwarded to the licensee but will not preclude the cancellation of the licence. Paragraph 2.4.3.1 applies *mutatis mutandis*.

If the CTM proprietor alleges fraud on the part of the licensee, it must provide a final Court order to this effect. In fact it is not up to the Office to carry out any investigation in that respect.

Where several licences have been requested simultaneously, it is possible to cancel one of these licences individually. In such a case a new entry number will be created in respect of the cancelled licence.

The entry in the Register of licences which are limited in time, that is, temporary licences, does not automatically expire and must instead be cancelled from the Register.

3.2.2 Modification of a licence

Rule 35(6) CTMIR

In the case of a joint request from the CTM applicant or proprietor and the licensee, no further proof for the amendment of the licence is required.

If the request is made by the CTM applicant or proprietor, proof of the amendment of the licence is required only where the amendment for which entry in the Register is sought is of such a nature that it would diminish the rights of the registered licensee under the licence. This would be the case, for example, where the licensee's name were to change, where an exclusive licence were to become a non-exclusive licence, or where the licence were to become restricted regarding its territorial scope, the period of time for which it is granted, or the goods or services to which it applies.

If the request is made by the registered licensee, proof of the amendment of the licence is required only where the amendment for which entry in the Register is sought is of such a nature that it would extend the rights of the registered licensee under the licence. This would be the case, for example, where a non-exclusive licence were to become an exclusive licence, or where any registered restrictions of the licence as to its territorial scope, to the period of time for which it is granted, or to the goods or services to which it applies, were to be cancelled fully or in part.

If proof of the amendment of the licence is necessary, it is sufficient if any of the documents referred to above in paragraph 2.4.3.4 are submitted, subject to the following requirements.

- The written agreement must be signed by the other party to the licence contract and must relate to the registration of the amendment of the licence as requested.
- The Request for Amendment/Cancellation of a License must indicate how the licence has been amended.
- The copy or extract of the licence agreement must be of the licence as amended.

3.3 Contents of the request

Rules 26, 35 CTMIR

Paragraph 2.4 applies, save that the data concerning the licensee need not be indicated except in the case of a modification of the registered licensee's name.

Paragraph 2.5 applies if a modification of the scope of the licence is requested, for example, if a licence becomes a temporary licence or if the geographical scope of a licence is changed.

3.4 Fees

3.4.1 Cancellation of a licence

Article 162(2) CTMR
Rule 35(3) CTMIR
Article 2(24) CTMFR

The request for the cancellation of the registration of a licence is not deemed to have been filed until the required fee is paid, which amounts to EUR 200 for each CTM for which the cancellation is requested. Where several cancellations are requested simultaneously or within the same request, and where the respective CTM applicant or proprietor and the licensee are the same in each case, the fee is limited to a maximum of EUR 1 000.

Once the corresponding fee has been paid, the fee will not be reimbursed if the request is refused or withdrawn.

3.4.2 Modification of a licence

Rule 35(6) CTMIR

The modification of the registration of a licence is not subject to a fee.

3.5 Examination of the request

3.5.1 Fees

Rule 35(3) CTMIR

Where the required fee for the request for the cancellation of a licence has not been received, the Office will notify the recordal applicant that the request is deemed not to have been filed.

3.5.2 Examination by the Office

Rule 35(2), (4) CTMIR

As for the mandatory elements of the request, paragraph 2.6.2 applies *mutatis mutandis*, including in respect of proof of the licence, to the extent that such proof is required.

The Office will notify the recordal applicant of any deficiency, setting a time limit of two months. If the deficiencies are not remedied, the Office will refuse the request for cancellation or modification.

Rules 35(6), 84(5) CTMIR

Paragraph 2.6.3 applies to the extent that the modification of the licence would affect its nature or its limitation to a part of the goods and services covered by the CTM/CTMA.

The registration of the cancellation or modification of the licence will be communicated to the person who made the request; if the request was filed by the licensee, the CTMA applicant or CTM proprietor will receive a copy of that communication.

3.6 Registration and publication

Rule 84(3)(s), Rule 85(2) CTMIR

In the case of a registered CTM, the creation, cancellation or modification will be entered in the Register of Community Trade Marks and published in the Community Trade Marks Bulletin under C.4.

In the case of a CTM application, the cancellation or modification of the licence will be mentioned in the files of the CTM application concerned. When the registration of the CTM is published, no publications will be made in respect of licences that have been cancelled, and in the case of the modification of the licence, the data as modified will be published under C.4.

4 Transfer of a Licence for a CTM or CTMA

4.1 Definition of the transfer of a licence

Article 22(5) CTMR

A licence concerning a CTMA or a CTM may be transferred. The transfer of a licence is different from a sub-licence insofar as the former licensee loses all its rights under the licence, and will be replaced by a new licensee, whereas in the case of a transfer of sub-licence, the main licence remains in force. Likewise, the transfer of a licence is different to a change of name of the owner where no change of ownership is implied (see the Guidelines, Part E, Section 3, CTMs as Objects of Property, Chapter 1, Transfer).

4.2 Applicable rules

Rule 33(1) CTMIR

The procedure for the registration of a transfer of a licence follows the same rules as the registration of a licence set out in paragraphs 2 and 3 above.

Rule 33(1), (4) CTMIR
Article 2(23)(b) CTMFR

The transfer of a licence is subject to the payment of a fee. Paragraph 2.3 above applies *mutatis mutandis*.

To the extent that a declaration or a signature of the CTMA applicant or CTM proprietor is required in accordance with the rules, its place shall be taken by a declaration or signature of the registered licensee (the former licensee).

5 Registration of Licences for Registered Community Designs

Articles 27, 32, 33, Article 51(4) CDR
Articles 24, 25, 26, Article 27(2) CDIR
Annex Nos 18, 19 CDFR

The legal provisions contained in the CDR, CDIR and CDFR for licences correspond to the respective provisions in the CTMR, CTMIR and CTMFR.

Therefore, both the legal principles and the procedure for the registration, cancellation or amendment of trade mark licences apply *mutatis mutandis* to Community designs, save for the following exceptions and specificities.

5.1 Registered Community designs

There is no use requirement in the Community design law, so that the issue of whether use by a licensee is use with the consent of the right holder does not arise.

The CDR and CDIR require the indication of the products in which the design is intended to be incorporated or applied.

It is not possible to register a licence for a registered Community design for only part of the products it covers.

Any such limitations of the scope of the licence will be disregarded by the Office, and the licence will be registered as if the restriction were not present.

5.2 Multiple applications for registered Community designs

Article 37 CDR
Article 24(1) CDIR

An application for a registered Community design may be in the form of a multiple application containing several designs.

For the purposes of the legal effect of licences, as well as of the procedure for registering licences, the individual designs contained in a multiple application shall be dealt with as if they were separate applications, and the same continues to apply after registration of the designs contained in the multiple application.

In other words, each design contained in a multiple application may be licensed independently of the others.

The optional indications as to the kind of licence and the procedure for their examination referred to above in paragraphs 2.5 and 2.6.1 (with the exception of a licence limited to some products, which is not possible) apply to each of the individual designs contained in a multiple application separately and independently.

Annex Nos 18, 19 CDFR

The fee of EUR 200 for the registration of a licence, the transfer of a licence or the cancellation of a licence applies per design and not per multiple application. The same is true for the ceiling of EUR 1 000 if multiple requests are submitted.

Example 1: Out of a multiple application for 10 designs, 6 designs are licensed, in favour of the same licensee. The fee is EUR 1 000 provided that one single request for registration of these 6 licences is submitted or several requests are submitted on the same day. The request may indicate that for three out of these six designs the licence is an exclusive licence, without affecting the fees to be paid.

Example 2: Out of a multiple application for 10 designs, 5 designs are licensed in favour of the same licensee. A licence is also granted for another design not contained in that multiple application. The fee is EUR 1 000 provided that

- one single request for registration of these 6 licences is submitted or several requests are submitted on the same day, and
- the holder of the Community design and the licensee are the same in all 6 cases.

6 Registration of Licences for International Trade Marks

The Madrid System allows for the recording of licences against an international registration. All requests for recording a licence should be submitted on form MM13 either directly to the International Bureau by the recorded holder or through the Office of the recorded holder or through the Office of a contracting party in respect of which the licence is granted or through the Office of the licensee. The request cannot be submitted directly to the International Bureau by the licensee. The Office's own Recordal Application form should not be used.

Detailed information on the recording of licences can be found in Sections B.II.93.01 to 99.04 of the Guide to the International Registration of Marks under the Madrid Agreement and the Madrid Protocol (www.wipo.int/madrid/en/guide/). For further information on international trade marks, see the Guidelines, Part M.

***GUIDELINES FOR EXAMINATION IN THE
OFFICE FOR HARMONIZATION IN THE
INTERNAL MARKET (TRADE MARKS AND
DESIGNS) ON COMMUNITY TRADE MARKS***

PART E

REGISTER OPERATIONS

SECTION 3

CTMs AS OBJECTS OF PROPERTY

CHAPTER 3

RIGHTS IN REM

Table of Contents

1	Introduction.....	4
1.1	Applicable Law	4
1.2	Advantages of the registration of a right in rem	5
2	Requirements for a Request for the Registration of a Right in Rem.....	6
2.1	Application form and requests for more than one right in rem.....	6
2.2	Languages	6
2.3	Fees	7
2.4	Applicants and mandatory content of the application.....	7
2.4.1	Applicants	7
2.4.2	Mandatory indications concerning the CTM and the pledgee	7
2.4.3	Requirements concerning the person who submits the request – signature, proof of the right in rem, representation	8
2.4.3.1	Request submitted by the CTM proprietor alone	8
2.4.3.2	Request submitted jointly by the CTM proprietor and the pledgee.....	9
2.4.3.3	Request submitted by the pledgee alone	9
2.4.3.4	Proof of the right in rem	9
2.4.4	Representation	10
2.5	Examination of the request for registration.....	10
2.5.1	Fees.....	10
2.5.2	Examination of the mandatory formalities	10
2.6	Registration procedure and publications	12
3	Procedure for the Cancellation or Modification of the Registration of a Right in Rem	13
3.1	Competence, languages, submission of the request.....	13
3.2	Person submitting the request.....	13
3.2.1	Cancellation of the registration of a right in rem.....	13
3.2.2	Modification of the registration of a right in rem	14
3.3	Contents of the request	14
3.4	Fees	15
3.4.1	Cancellation of the registration of a right in rem.....	15
3.4.2	Modification of the registration of a right in rem	15
3.5	Examination of the request.....	15
3.5.1	Fees.....	15
3.5.2	Examination by the Office.....	15
3.6	Registration and publication	16
4	Procedure for the Transfer of a Right in Rem	16
4.1	Provision for the transfer of a right in rem	16
4.2	Applicable rules.....	16
5	Rights in Rem for Registered Community Designs.....	17

5.1	Multiple applications for registered Community designs.....	17
6	Rights in Rem for International Trade Marks	18

1 Introduction

Article 19 CTMR Rules 33, 35 CTMIR Article 24 CDR

Both registered Community trade marks (CTMs) and Community trade mark applications (CTMAs) may be the subject of rights in rem.

Both registered Community designs (RCDs) and registered Community design applications may be the subject of rights in rem.

Paragraphs 1 to 4 of this chapter deal with rights in rem concerning CTMs and CTMAs. The provisions in the CDR and CDIR dealing with rights in rem concerning designs are almost identical to the equivalent provisions of the CTMR and CTMIR respectively. Therefore, the following applies *mutatis mutandis* to Community designs. Procedures specific to Community designs are detailed in paragraph 5 below. Procedures specific to international trade marks are detailed in paragraph 6 below.

A 'right in rem' or 'real right' is a limited property right which is an absolute right. Rights in rem refer to a legal action directed toward property, rather than toward a particular person, allowing the owner of the right the opportunity to recover, possess or enjoy a specific object. These rights may apply to trade marks or designs. They may consist, inter alia, in use rights, usufruct or pledges. 'In rem' is different from 'in personam,' which is directed toward a particular person.

The most common rights in rem for trade marks or designs are pledges or securities. They secure the repayment of a debt of the proprietor of the trade mark or design (i.e. the debtor) in such a way that, where it cannot repay the debt, the creditor (i.e. the owner of the pledge or security) may receive repayment of the debt by, for example, selling the trade mark or design. Other examples are DE: Pfand, Hypothek; EN: Guarantees, Warranties, Bails and Sureties; ES: Hipoteca; FR: Nantissement, Gage, Hypothèque, Garantie, Caution; IT: Pegno, Ipoteca.

There are two types of right in rem that the applicant can ask to be noted in the file or entered in the Register:

- rights in rem that serve the purpose of guaranteeing securities (pledge, charge, etc.)
- rights in rem that do not serve as a guarantee (usufruct).

1.1 Applicable Law

Article 16 CTMR

The CTMR does not establish unified and complete provisions applicable to rights in rem for CTMs or CTMAs. Rather, Article 16 CTMR refers to the law of a Member State regarding the acquisition, validity and effects of the CTM as an object of property. To this end, a right in rem for a CTM is, in its entirety and for the whole territory of the Community, assimilated to a right in rem for a trade mark registered in the Member State in which the CTM proprietor or applicant has its seat or its domicile, or, if this is

not the case, to a right in rem for a trade mark registered in the Member State in which the proprietor has an establishment, or if this is not the case, to a right in rem for a trade mark registered in Spain (Member State in which the seat of the Office is situated).

This, however, applies only to the extent that Articles 17 to 24 CTMR do not provide otherwise.

Article 16 CTMR is limited to the effects of a right in rem as an object of property, and does not extend to contract law. Article 16 CTMR does not govern the applicable law, or the validity, of a right in rem contract, which means that the freedom of the contracting parties to submit the right in rem contract to a given national law is not affected by the CTMR.

1.2 Advantages of the registration of a right in rem

Articles 19(2), 23(1) CTMR

It is not compulsory to register rights in rem, nor is registration a condition for considering the use of a trade mark by a pledgee under the terms of the right in rem contract to have been made with the consent of the proprietor pursuant to Article 15(2) CTMR,. However, such a registration has particular advantages.

- a) In view of the provision of Article 23(1) CTMR, vis-à-vis third parties who might have acquired or have entered in the Register rights in the trade mark which are incompatible with the registered right in rem, the pledgee may avail itself of the rights conferred by this right in rem only:
 - if the right in rem was entered in the Register of Community Trade Marks, or
 - in the absence of registration of the right in rem, if the third party had acquired its rights after the date of the acquisition of the rights in rem knowing of the existence of the right in rem.
- b) In the event that a right in rem for a Community trade mark is entered in the Register, the surrender of that mark by its proprietor will only be entered in the Register if the proprietor establishes that it has informed the pledgee of its intention to surrender.

The pledgee of a right in rem which is registered has, therefore, the right to be informed in advance by the trade mark's proprietor of its intention to surrender the trade mark.

- c) In the event that a right in rem for a Community trade mark is entered in the Register, the Office will notify the pledgee at least six months before the expiry of the registration that the registration is approaching expiry. The Office will also notify the pledgee of any loss of rights and of the expiry of the registration, where applicable.
- d) Recording rights in rem is important for maintaining the veracity of the Register, particularly in the event of *inter partes* proceedings.

2 Requirements for a Request for the Registration of a Right in Rem

Article 19(2) CTMR
Rule 33, Rule 84(3)(h) CTMIR

Both CTMAs and CTMs may be the subject of the registration of a right in rem.

The application for registration of a right in rem must comply with the following conditions.

2.1 Application form and requests for more than one right in rem

Rule 95(a) and (b) CTMIR

It is strongly recommended that the request for registration of a right in rem for a CTM be submitted on the Recordal Application form. This form is available free of charge in the official languages of the European Union. It can be downloaded from OHIM's website.

Any language version of this form may be used, provided that it is completed in one of the languages referred to in paragraph 2.2 below.

Rules 31(7), 33(1) CTMIR

A single request for the registration of a right in rem for two or more registered CTMs or CTMAs may be submitted only if the respective registered proprietor and pledgee are the same in each case.

2.2 Languages

Rule 95(a) CTMIR

The application for the registration of a right in rem for a CTMA may be submitted in the first or second language of the CTM application.

Rule 95(b) CTMIR

The application for the registration of a right in rem for a CTM must be submitted in one of the five languages of the Office, namely, English, French, German, Italian or Spanish.

2.3 Fees

Article 162(2)(c) and (d) CTMR
Rule 33(1) and (4) CTMIR
Article 2(23) CTMFR

The application for the registration of a right in rem is considered not to have been submitted until the fee is paid. The fee is EUR 200 for each Community trade mark for which the registration of a right in rem is requested.

However, where several registrations of rights in rem have been requested in a single request and the registered proprietor and the pledgee are the same in all cases, the fee is limited to a maximum of EUR 1 000.

The same maximum amount applies where several registrations of rights in rem are applied for at the same time, provided that they could have been filed in a single request and where the registered proprietor and the pledgee are the same in all cases.

Once the corresponding fee is paid, the fee will not be reimbursed if the application for registration of the right in rem is refused or withdrawn (file classified).

2.4 Applicants and mandatory content of the application

2.4.1 Applicants

Article 19(2) CTMR

The registration of a right in rem may be requested by:

- a) the proprietor(s) of the CTM, or
- b) the proprietor(s) of the CTM jointly with the pledgee(s), or
- c) the pledgee(s).

The formal conditions with which the request must comply depend on who submits the request. It is recommended that the first or the second of these options be used, since these allow for a speedier and smoother treatment of the request for registration of the right in rem.

2.4.2 Mandatory indications concerning the CTM and the pledgee

Rule 31, Rule 33(1) CTMIR

The request for registration of a right in rem must contain the following information.

Rule 31(1)(a), Rule 33(1) CTMIR

- a) The registration number of the CTM concerned. If the request relates to several CTMs each of the numbers must be indicated.

Rules 1(1)(b), 31(1)(b), Rule 33(1) CTMIR

- b) The pledgee's name, address and nationality and the State in which it is domiciled or has its seat or an establishment.

Rule 1(1)(e), Rules 31(2), 33(1) CTMIR

- c) If the pledgee designates a representative, the representative's name and business address must be indicated; the indication of the address may be replaced by the indication of the ID number allocated by the Office.

2.4.3 Requirements concerning the person who submits the request – signature, proof of the right in rem, representation

Rule 79, Rule 82(3) CTMIR

The requirements concerning signature, proof of the right in rem and representation vary depending on the person who submits the request. Where the requirement of a signature is referred to, pursuant to Rule 79 and Rule 82(3) CTMIR, in electronic communications, the indication of the sender's name will be deemed equivalent to the signature.

2.4.3.1 Request submitted by the CTM proprietor alone

Rule 1(1)(b), Rule 33(1) CTMIR

When a request is submitted on behalf of the CTM proprietor alone, it must be signed by the CTM proprietor. In the case of co-ownership, all co-owners must sign or appoint a common representative.

No proof of the right in rem is necessary.

The Office will not inform the pledgee that the registration of the right in rem has been requested. It will, however, inform the pledgee when the right in rem is recorded in the Register.

Where the pledgee files a statement with the Office in which it opposes the registration of the right in rem, the Office will forward the statement to the CTM proprietor for information purposes only. The Office will not take any further action on such a statement. Following the registration of the right in rem, any pledgee who disagrees with the registration of the right in rem may request the cancellation or modification of the registration of the right in rem (see paragraph 3 below).

The Office will not take into account whether the parties have agreed to register a right in rem contract at the Office. Any dispute on whether or not and in what manner the right in rem should be registered is a matter that must be resolved between the parties concerned under the relevant national law (Article 16 CTMR).

2.4.3.2 Request submitted jointly by the CTM proprietor and the pledgee

When the request is submitted jointly by the CTM proprietor and the pledgee, it must be signed by both parties. In the case of co-ownership, all co-owners must sign or appoint a common representative.

In this case, the signature of both parties constitutes proof of the right in rem.

Where there is a formal deficiency regarding the signature or the representative of the pledgee, the request will still be accepted as long as it would have also been acceptable if it had been submitted by the CTM proprietor alone.

The same applies where there is a deficiency regarding the signature or representative of the CTM proprietor but where the request would have been acceptable if it had been submitted by the pledgee alone.

2.4.3.3 Request submitted by the pledgee alone

The request may also be submitted by the pledgee alone. In this case, it must be signed by the pledgee.

In addition, proof of the right in rem must be submitted.

2.4.3.4 Proof of the right in rem

There is sufficient proof of the right in rem if the request for registration of the right in rem is accompanied by any of the following evidence.

- A declaration, signed by the CTM proprietor, that it agrees to the registration of the right in rem.

In accordance with Rule 31(5)(a) CTMIR, it is also considered sufficient proof if the request for registration of the right in rem is signed by both parties. This case has already been dealt with under paragraph 2.4.3.2 above.

- The right in rem contract, or an extract therefrom, indicating the CTM at issue and the parties, and bearing their signatures.

It suffices if the right in rem agreement is submitted. In many instances, the parties to the right in rem contract will not wish to disclose all the details of the contract, which may contain confidential information about the terms and conditions of the pledge. In these cases it suffices if only a part or an extract of the right in rem agreement is submitted, as long as it identifies the parties to the right in rem agreement and the CTM that is subject to a right in rem, and bears the signatures of both parties. All other elements may be omitted or blacked out.

- An uncertified statement of a right in rem, signed by both the CTM proprietor and the pledgee.

Original documents become part of the file and, therefore, cannot be returned to the person who submitted them. Simple photocopies are sufficient. The original

or photocopy does not need to be authenticated or legalised unless the Office has reasonable doubts as to the veracity of the documents.

Rule 95(a) and (b), Rule 96(2) CTMIR

The evidence of the right in rem must be:

- a) in the language of the Office which has become the language of the proceedings for the registration of the right in rem, see paragraph 2.2 above;
- b) in any official language of the Community other than the language of the proceedings; in this case the Office may require a translation of the document into a language of the Office to be filed within a period specified by the Office.

Where the supporting documents are not submitted in either an official language of the European Union or in the language of the proceedings, the Office may require a translation into the language of the proceedings or, at the choice of the party requesting the registration of the right in rem, in any language of the Office. The Office will set a time limit of two months from the date of notification of that communication. If the translation is not submitted within that time limit, the document will not be taken into account and will be deemed not to have been submitted.

2.4.4 Representation

Articles 92(2), 93(1) CTMR

The general rules on representation apply (see the Guidelines, Part A, General Rules, Section 5, Professional Representation).

2.5 Examination of the request for registration

2.5.1 Fees

Rule 33(2) CTMIR

Where the required fee has not been received, the Office will notify the recordal applicant that the request is deemed not to have been filed because the relevant fee has not been paid. However, a new request may be submitted at any time providing the correct fee is paid from the outset.

2.5.2 Examination of the mandatory formalities

Rule 33(3) CTMIR

The Office will check whether the request for registration of the right in rem complies with the formal conditions mentioned in paragraph 2.4 above (indication of the CTM number(s), the required information concerning the pledgee, the representative of the pledgee where applicable).

The validity of the right in rem agreement will not be examined.

Article 93(1) CTMR
Rules 33, 76, 77 CTMIR

The Office will check whether the request for registration of the right in rem has been duly signed. Where the request is signed by the pledgee's representative, an authorisation may be required by the Office or, in the context of *inter partes* proceedings, by the other party to those proceedings. In this event, if no authorisation is submitted, the proceedings will continue as if no representative had been appointed. Where the request for registration of the right in rem is signed by the proprietor's representative who has already been designated as the representative for the CTM in question, the requirements relating to signature and authorisations are fulfilled.

Articles 92(2), 93(1) CTMR

The examination will include whether the recordal applicant (i.e. the CTM proprietor or the pledgee) is obliged to be represented before the Office (see paragraph 2.4.4 above).

Rule 33(3) CTMIR

The Office will inform the recordal applicant in writing of any deficiencies in the application. If the deficiencies are not remedied within the time limit set in that communication, which will normally be two months following the date of the notification, the Office will reject the request for registration of the right in rem. The party concerned may file an appeal against this decision. (See Decision 2009-1 of 16 June 2009 of the Presidium of the Boards of Appeal regarding Instructions to Parties in Proceedings before the Boards of Appeal).

Where the request has been submitted jointly by the CTM proprietor and the pledgee, the Office will communicate with the CTM proprietor and send a copy to the pledgee.

Where the pledgee has also submitted and signed the request, it will not be allowed to contest the existence or scope of the right in rem agreement.

Where the request for registration of the right in rem is submitted by the CTM proprietor alone, the Office will not inform the pledgee. The examination of evidence of the right in rem will be done *ex officio*. The Office will disregard any statements or allegations of the pledgee regarding the existence or scope of the right in rem or its registration; the pledgee cannot oppose the registration of a right in rem.

Rule 33(3) CTMIR

If the request is filed by the pledgee on the basis of a copy of the right in rem agreement, and where the Office has reasonable doubts as to the veracity of the documents, it will write to the pledgee inviting it to remove those doubts. The pledgee will then have the burden of proving that the right in rem exists, that is, it has to convince the Office of the veracity of the documents. In such a case, the Office may, within the scope of its *ex officio* power of examination (Article 76(1) CTMR), invite the

CTM proprietor to submit observations. If the proprietor claims that the documents are falsified, this will be enough for the Office to reject the registration of a right in rem unless the pledgee produces a Court order from an EU Member State in its favour. In any case, if the doubts cannot be removed, the registration of the right in rem will be refused. In such a case, the procedure always remains *ex parte* even though the CTM proprietor is heard; it is not a party to the proceedings. The party concerned may file an appeal against this decision.

2.6 Registration procedure and publications

Rule 33(4) CTMIR

The right in rem for CTMAs will be mentioned in the files kept by the Office for the Community trade mark application concerned.

Rule 84(3)(h), Rule 85(2) CTMIR

When the mark is registered, the right in rem will be published in the Community Trade Marks Bulletin and entered in the Community Trade Mark Register.

Rule 84(5) CTMIR

The Office will notify the recordal applicant of the entry of the right in rem in the files kept by the Office. Where applicable, the CTM applicant will also be notified.

Article 22(5) CTMR Rule 84(3)(h), Rule 85(2) CTMIR

For CTMs, the Office will enter the right in rem in the Community Trade Mark Register and publish it in the Community Trade Marks Bulletin.

Access to this information may be obtained through inspection of files (see the Guidelines, Part E, Register Operations, Section 5, Inspection of Files).

Rights in rem are published in Part C.5. of the Bulletin.

Rule 84(5) CTMIR

The Office will inform the recordal applicant of the registration of the right in rem. When the request for registration of the right in rem was filed by the pledgee, the Office will also inform the CTM proprietor of the registration.

3 Procedure for the Cancellation or Modification of the Registration of a Right in Rem

Rule 35(1) CTMIR

The registration of a right in rem will be cancelled or modified at the request of an interested party, that is, the applicant or proprietor of the CTM or the registered pledgee.

3.1 Competence, languages, submission of the request

Article 133 CTMR
Rule 35(3), (6) and (7) CTMIR

Paragraphs 2.1 and 2.2 above apply.

There is no Office form for registering the cancellation or modification of a right in rem.

3.2 Person submitting the request

Rule 35(1) CTMIR

The request for the cancellation or modification of the registration of a right in rem may be submitted by:

- a) the CTM applicant/proprietor and the pledgee jointly,
- b) the CTM applicant/proprietor, or
- c) the registered pledgee.

3.2.1 Cancellation of the registration of a right in rem

Rule 35(4) CTMIR

If the CTM applicant/proprietor and the pledgee submit a joint request or if the pledgee alone submits a request, no proof of the cancellation of the registration of the right in rem is required since the application itself implies a statement by the pledgee that it consents to the cancellation of the registration of the right in rem. When the request for cancellation is submitted by the CTM applicant/proprietor, the request must be accompanied by evidence establishing that the registered right in rem no longer exists or by a declaration by the pledgee that it consents to the cancellation.

Where the registered pledgee submits the request for cancellation by itself, the CTM applicant/proprietor will not be informed of this request. Any observations filed by the proprietor will be forwarded to the pledgee but will not preclude the cancellation of the registration of the right in rem. Paragraph 2.4.3.1 above applies *mutatis mutandis*.

If the CTM proprietor alleges fraud on the part of the pledgee, it must provide a Court order to this effect. It is not up to the Office to carry out any investigation into such a claim.

Where the registration of several rights in rem has been requested simultaneously, it is possible to cancel one of these registrations individually. In such an event, a new recordal number will be created for the cancelled right in rem.

3.2.2 Modification of the registration of a right in rem

Rule 35(6) CTMIR

If the CTM applicant/proprietor and the pledgee submit a joint request, no further proof for the modification of the registration of the right in rem is required.

If the request is submitted by the CTM applicant/proprietor, proof of the modification of the registration of the right in rem is required only where the modification is of such a nature that it would diminish the rights of the registered pledgee under the right in rem. This would be the case, for example, of a change of the pledgee's name.

If the request is submitted by the registered pledgee, proof of the modification of the registration of the right in rem is required only where the modification, is of such a nature that it would extend the rights of the registered pledgee under the right in rem.

If proof of the modification of the registration of the right in rem is necessary, it is sufficient if any of the documents referred to above under paragraph 2.4.3.4 are submitted, subject to the following requirements.

- The written agreement must be signed by the other party to the right in rem agreement and must relate to the registration of the modification of the right in rem as requested.
- The request for modification/cancellation of the registration of a right in rem must show the right in rem in its amended form.
- The copy or extract of the right in rem agreement must show the right in rem in its amended form.

3.3 Contents of the request

Rules 26, 35 CTMIR

Paragraph 2.4 above applies, except that the data concerning the pledgee need not be indicated except in the event of a modification of the registered pledgee's name.

3.4 Fees

3.4.1 Cancellation of the registration of a right in rem

Article 162(2) CTMR
Rule 35(3) CTMIR
Article 2(24) CTMFR

The request for the cancellation of the registration of a right in rem is not deemed to have been filed until the required fee of EUR 200 per cancellation is paid. Where several cancellations are requested simultaneously or within the same request, and where the CTM applicant/proprietor and the pledgee are the same in each case, the fee is limited to a maximum of EUR 1 000.

Once the corresponding fee has been paid, the fee will not be reimbursed if the request is refused or withdrawn.

3.4.2 Modification of the registration of a right in rem

Rule 35(6) CTMIR

The modification of the registration of a right in rem is not subject to a fee.

3.5 Examination of the request

3.5.1 Fees

Rule 35(3) CTMIR

Where the required fee for the request for the cancellation of the registration of a right in rem has not been received, the Office will notify the recordal applicant that the request is deemed not to have been filed.

3.5.2 Examination by the Office

Rule 35(2) and (4) CTMIR

Paragraph 2.5.2 applies *mutatis mutandis* to the mandatory elements of the request, even for proof of the right in rem, to the extent that such proof is required. The Office will notify the recordal applicant of any deficiency, setting a time limit of two months. If the deficiencies are not remedied, the Office will refuse the request for registering the cancellation or modification.

Rules 35(6), 84(5) CTMIR

The registration of the cancellation or modification of the right in rem will be communicated to the person who submitted the request; if the request was submitted by the pledgee, the CTM applicant/proprietor will receive a copy of the communication.

3.6 Registration and publication

Rule 84(3)(s), Rule 85(2) CTMIR

For a registered CTM, the creation, cancellation or modification of a registration of a right in rem will be entered in the Register of Community Trade Marks and published in the Community Trade Marks Bulletin under C.5.

For a CTM application, the cancellation or modification of the right in rem will be mentioned in the files of the CTM application concerned. When the registration of the CTM is published, no publications will be made for rights in rem that have been cancelled, and if a right in rem has been modified, the data as modified will be published under C.5.

4 Procedure for the Transfer of a Right in Rem

4.1 Provision for the transfer of a right in rem

Rule 33(1) CTMIR

A right in rem may be transferred.

4.2 Applicable rules

Rule 33(1) CTMIR

The procedure for the registration of a transfer of a right in rem follows the same rules as the registration of a right in rem set out in paragraph 2 above.

Rule 33(1) and (4) CTMIR
Article 2(23)(b) CTMFR

The transfer of a right in rem is subject to the payment of a fee. Paragraph 2.3 above applies *mutatis mutandis*.

To the extent that a declaration or a signature of the CTM applicant/proprietor is required in accordance with the rules, it must be replaced by a declaration or signature of the registered pledgee (the former pledgee).

5 Rights in Rem for Registered Community Designs

Articles 27, 29, and 33, Article 51(4) CDR
Articles 24 and 26, Article 27(2) CDIR
Annex (18) and (19) CDFR

The legal provisions contained in the CDR, CDIR and CDFR in respect of rights in rem correspond to the respective provisions in the CTMR, CTMIR and CTMFR.

Therefore, both the legal principles and the procedure in respect of the registration, cancellation or modification of trade mark rights in rem apply *mutatis mutandis* to Community designs, except for the following specific procedures.

5.1 Multiple applications for registered Community designs

Article 37 CDR
Article 24(1) CDIR

An application for a registered Community design may be in the form of a multiple application, applying for several designs.

For the purposes of the legal effect of rights in rem, as well as of the procedure for registering rights in rem, individual designs contained in a multiple application will be dealt with as if they were separate applications, and the same continues to apply after registration of the designs contained in the multiple application.

In other words, each design contained in a multiple application may be pledged independently of the others.

Annex (18) and (19) CDFR

The fee of EUR 200 for the registration of a right in rem or the cancellation of a right in rem applies per design and not per multiple application. The same is true for the ceiling of EUR 1 000 if multiple requests are submitted.

Example 1

Out of a multiple application for 10 designs, 6 designs are pledged, in favour of the same pledgee. The fee is EUR 1 000 provided that either a single request for registration of these 6 rights in rem is submitted or several requests are submitted on the same day.

Example 2

Out of a multiple application for 10 designs, 5 designs are pledged, in favour of the same pledgee. The registration for a right in rem is also requested for another design not contained in that multiple application. The fee is EUR 1 000 Euro provided that:

- either a single request for registration of these 6 rights in rem is submitted or several requests are submitted on the same day, and
- the holder of the Community design and the pledgee are the same in all 6 cases.

6 Rights in Rem for International Trade Marks

The Madrid System allows for the recording of rights in rem against an international registration (see Rule 20 [Common Regulations under the Madrid Agreement Concerning the International Registration of Marks and the Protocol Relating to that Agreement](#)). For the convenience of the users, the [MM19](#) form is available for requesting that a restriction of the holder's right of disposal be entered in the International Register. The use of this form is strongly recommended to avoid irregularities. Requests should be submitted either directly to the International Bureau by the holder or to the national IP Office of the holder or to the Office of a contracting party to whom the right in rem is granted or to the Office of the pledgee. The request cannot be submitted directly to the International Bureau by the pledgee. OHIM's own Recordal Application form should not be used.

Detailed information on the recording of rights in rem can be found in Part B, Chapter II, paragraphs 92.01 to 92.04 of the Guide to the International Registration of Marks under the Madrid Agreement and the Madrid Protocol (www.wipo.int/madrid/en/guide). For further information on international trade marks, see the Guidelines Part M, International Marks.

***GUIDELINES FOR EXAMINATION IN THE
OFFICE FOR HARMONIZATION IN THE
INTERNAL MARKET (TRADE MARKS AND
DESIGNS) ON COMMUNITY TRADE MARKS***

PART E

REGISTER OPERATIONS

SECTION 3

CTMs AS OBJECTS OF PROPERTY

CHAPTER 4

LEVY OF EXECUTION

Table of Contents

1	Introduction.....	4
1.1	Applicable Law	4
1.2	Advantages of the registration of a levy of execution	4
2	Requirements for a Request for the Registration of a Levy of Execution	5
2.1	Application form and requests for more than one levy of execution	5
2.2	Languages	6
2.3	Fees	6
2.4	Applicants and mandatory content of the application.....	7
2.4.1	Applicants	7
2.4.2	Mandatory indications concerning the CTM and the beneficiary	7
2.4.3	Requirements concerning the person who submits the request – signature, proof of the levy of execution, representation	8
2.4.3.1	Request submitted by the CTM proprietor.....	8
2.4.3.2	Request submitted by the beneficiary	8
2.4.3.3	Request submitted by a Court or Authority.....	8
2.4.3.4	Proof of the levy of execution	9
2.4.4	Representation	9
2.5	Examination of the request for registration.....	10
2.5.1	Fees.....	10
2.5.2	Examination of the mandatory formalities	10
2.6	Registration procedure and publications	11
3	Procedure for the Cancellation or Modification of the Registration of a Levy of Execution	11
3.1	Competence, languages, submission of the request.....	12
3.2	Person submitting the request.....	12
3.2.1	Cancellation of the registration of a levy of execution	12
3.2.2	Modification of the registration of a levy of execution	12
3.3	Contents of the request	13
3.4	Fees	13
3.4.1	Cancellation of the registration of a levy of execution	13
3.4.2	Modification of the registration of a levy of execution	13
3.5	Examination of the request.....	13
3.5.1	Fees.....	13
3.5.2	Examination by the Office.....	14
3.6	Registration and publication	14
4	Levy of Execution for Registered Community Designs	14
4.1	Multiple applications for registered Community designs.....	15

5 Levy of Execution for International Trade Marks..... 15

1 Introduction

Article 20 CTMR
Rules 33, 35 CTMIR
Article 29 CDR

Both registered Community trade marks (CTMs) and Community trade mark applications (CTMAs) may be levied in execution.

Both registered Community designs (RCDs) and registered Community design applications may be levied in execution.

Paragraphs 1 to 3 of this chapter deal with levies of execution concerning CTMs and CTMAs. The provisions in the CDR and CDIR dealing with levy of execution concerning designs are almost identical to the equivalent provisions of the CTMR and CTMIR respectively. Therefore, the following applies *mutatis mutandis* to Community designs. Procedures specific to Community designs are detailed in paragraph 4 below. Procedures specific to international trade marks are detailed in paragraph 5 below.

A levy of execution is the act by which a court officer appropriates a debtor's property, following a judgment of possession obtained by a plaintiff from a court. In this way a creditor can recover its claim from all the property of the debtor, including from its trade mark rights.

1.1 Applicable Law

Article 16 CTMR

The CTMR does not establish unified and complete provisions applicable to the levy of execution for CTMs or CTMAs. Rather, Article 16 CTMR refers to the law of a Member State, regarding the procedure for levy of execution. To this end, a levy of execution on a CTM is, in its entirety and for the whole territory of the Community, assimilated to a levy of execution for a trade mark registered in the Member State in which the CTM proprietor or applicant has its seat or its domicile, or, if this is not the case, to a levy of execution for a trade mark registered in the Member State in which the proprietor has an establishment, or if this is not the case, to a levy of execution for a trade mark registered in Spain (Member State in which the seat of the Office is situated).

This, however, applies only to the extent that Articles 17 to 24 CTMR do not provide otherwise.

1.2 Advantages of the registration of a levy of execution

Articles 20(2), 50(3), 23(3) CTMR
Rule 36(2) CTMIR

Registration of a levy of execution is not compulsory; however, such a registration has particular advantages:

- a) In view of the provision of Article 23(3) CTMR, vis-à-vis third parties who might have acquired or have entered in the Register rights in the trade mark which are incompatible with the registered levy of execution, the beneficiary may avail itself of the rights conferred by this levy of execution, if national law so permits, only:
- if the levy of execution was entered in the Register of Community Trade Marks, or
 - in the absence of registration of the levy of execution, if the third party had acquired its rights after the date of the adjudication of the levy of execution knowing of the existence of the levy of execution.
- b) In the event that a levy of execution against a Community trade mark is entered in the Register, the surrender of that mark by its proprietor will only be entered in the Register if the proprietor establishes that it has informed the beneficiary of its intention to surrender.

The beneficiary of a levy of execution which is registered has, therefore, the right to be informed in advance by the trade mark's proprietor of its intention to surrender the trade mark.

- c) In the event where a levy of execution against a Community trade mark is entered in the Register, the Office will notify the beneficiary at least six months before the expiry of the registration that the registration is approaching expiry. The Office will also notify the beneficiary of any loss of rights and of the expiry of the registration, where applicable.
- d) Recording a levy of execution is important for maintaining the veracity of the Register, particularly in the event of *inter partes* proceedings.

2 Requirements for a Request for the Registration of a Levy of Execution

Article 20(3) CTMR Rule 33, Rule 84(3)(i) CTMIR
--

Both CTMAs and CTMs may be the subject of the registration of a levy of execution.

The application for registration of a levy of execution must comply with the following conditions.

2.1 Application form and requests for more than one levy of execution

Rule 95(a) and (b) CTMIR

It is strongly recommended that the request for registration of a levy of execution for a CTM be submitted on the Recordal Application form. This form is available free of

charge in the official languages of the European Union. It can be downloaded from OHIM's website.

Any language version of this form may be used, provided that it is completed in one of the languages referred to in paragraph 2.2 below.

Rules 31(7), 33(1) CTMIR

A single request for the registration of a levy of execution for two or more registered CTMs or CTMAs may be submitted only if the respective registered proprietor and beneficiary are the same in each case.

2.2 Languages

Rule 95(a) CTMIR

The application for the registration of a levy of execution against a CTMA may be submitted in the first or second language of the CTM application.

Rule 95(b) CTMIR

The application for the registration of a levy of execution against a CTM must be submitted in one of the five languages of the Office, namely, English, French, German, Italian or Spanish.

2.3 Fees

Article 162(2)(c) and (d) CTMR
Rule 33(1) and (4) CTMIR
Article 2(23) CTMFR

The application for the registration of a levy of execution is considered not to have been submitted until the fee is paid. The fee is EUR 200 for each Community trade mark for which the registration of a levy of execution is requested.

However, where several registrations of levy of execution have been requested in a single request and the registered proprietor and the beneficiary are the same in all cases, the fee is limited to a maximum of EUR 1 000.

The same maximum amount applies where several registrations of levy of execution are applied for at the same time, provided that they could have been filed in a single request and where the registered proprietor and the beneficiary are the same in all cases.

Once the corresponding fee is paid, the fee will not be reimbursed if the application for registration of the levy of execution is refused or withdrawn (file classified).

Where the recordal applicant (see paragraph 2.4.1 below) is a Court or an Authority, no fee is to be paid and administrative cooperation is applied.

2.4 Applicants and mandatory content of the application

2.4.1 Applicants

Article 20(3) CTMR

The registration of a levy of execution may be requested by:

- a) the proprietor(s) of the CTM,
- b) the beneficiary of the levy of execution,
- c) a Court or Authority.

The formal conditions with which the request must comply depend on who submits the request.

2.4.2 Mandatory indications concerning the CTM and the beneficiary

Rule 31, Rule 33(1) CTMIR

The request for registration of a levy of execution must contain the following information.

Rule 31(1)(a), Rule 33(1) CTMIR

- a) The registration number of the CTM concerned. If the request relates to several CTMs each of the numbers must be indicated.

Rules 1(1)(b), 31(1)(b), Rule 33(1) CTMIR

- b) The beneficiary's name, address and nationality and the State in which it is domiciled or has its seat or an establishment.

Rule 1(1)(e), Rules 31(2), 33(1) CTMIR

- c) If the beneficiary designates a representative, the representative's name and business address must be indicated; the indication of the address may be replaced by the indication of the ID number allocated by the Office.

2.4.3 Requirements concerning the person who submits the request – signature, proof of the levy of execution, representation

Rule 79, Rule 82(3) CTMIR

The requirements concerning signature, proof of the levy of execution and representation vary depending on the person who submits the request. Where the requirement of a signature is referred to, pursuant to Rule 79 and Rule 82(3) CTMIR, in electronic communications, the indication of the sender's name will be deemed equivalent to the signature.

2.4.3.1 Request submitted by the CTM proprietor

Rule 1(1)(b), Rule 33(1) CTMIR

When a request is submitted on behalf of the CTM proprietor, it must be signed by the CTM proprietor. In the case of co-ownership, all co-owners must sign or appoint a common representative.

The Office will not inform the beneficiary that the registration of the levy of execution has been requested. It will, however, inform the beneficiary when the levy of execution is recorded in the Register.

Where the beneficiary files a statement with the Office in which it opposes the registration of the levy of execution, the Office will forward the statement to the CTM proprietor for information purposes only. The Office will not take any further action on such a statement. Following the registration of the levy of execution, any beneficiary who disagrees with the registration of the levy of execution may request the cancellation or modification of the registration of the levy of execution (see paragraph 3 below).

Any dispute on whether or not and in what manner the levy of execution should be registered is a matter that must be resolved between the parties concerned under the relevant national law (Article 16 CTMR).

2.4.3.2 Request submitted by the beneficiary

The request may also be submitted by the beneficiary. In this case, it must be signed by the beneficiary.

In addition, proof of the levy of execution must be submitted.

2.4.3.3 Request submitted by a Court or Authority

The request may also be submitted by the Court or Authority issuing the judgment. In this case, it must be signed by the Court or Authority.

In addition, proof of the levy of execution must be submitted.

2.4.3.4 Proof of the levy of execution

There is sufficient proof of the levy of execution if the request for registration of the levy of execution is accompanied by the Court judgment.

In many instances, the parties to the levy of execution proceedings will not wish to disclose all the details of the judgment, which may contain confidential information. In these cases it suffices if only a part or an extract of the levy of execution judgment is submitted, as long as it identifies the parties to the levy of execution proceedings, the CTM that is subject to the levy of execution and that the judgment is final. All other elements may be omitted or blacked out.

Original documents become part of the file and, therefore, cannot be returned to the person who submitted them. Simple photocopies are sufficient. The original or photocopy does not need to be authenticated or legalised unless the Office has reasonable doubts as to the veracity of the documents.

Rule 95(a) and (b), Rule 96(2) CTMIR

The evidence of the levy of execution must be:

- a) in the language of the Office which has become the language of the proceedings for the registration of the levy of execution, see paragraph 2.2 above.
- b) in any official language of the European Union other than the language of the proceedings; in this case the Office may require a translation of the document into a language of the Office to be filed within a period specified by the Office.

Where the supporting documents are not submitted in either an official language of the European Union or in the language of the proceedings, the Office may require a translation into the language of the proceedings or, at the choice of the party requesting the registration of the levy of execution, in any language of the Office. The Office will set a time limit of two months from the date of notification of that communication. If the translation is not submitted within that time limit, the document will not be taken into account and will be deemed not to have been submitted.

2.4.4 Representation

Articles 92(2), 93(1) CTMR

The general rules on representation apply (see the Guidelines, Part A, General Rules, Section 5, Professional Representation).

2.5 Examination of the request for registration

2.5.1 Fees

Rule 33(2) CTMIR

Where the required fee has not been received, the Office will notify the recordal applicant (unless the recordal applicant is a Court or Authority, in which case no fee is required, see paragraph 2.3 above) that the request is deemed not to have been filed because the relevant fee has not been paid. However, a new request may be submitted at any time providing the correct fee is paid from the outset.

2.5.2 Examination of the mandatory formalities

Rule 33(3) CTMIR

The Office will check whether the request for registration of the levy of execution complies with the formal conditions mentioned in paragraph 2.4 above (indication of the CTM number(s), the required information concerning the beneficiary, the representative of the beneficiary where applicable).

The validity of the levy of execution judgment will not be examined.

Article 93(1) CTMR Rules 33, 76, 77 CTMIR

The Office will check whether the request for registration of the levy of execution has been duly signed. Where the request is signed by the beneficiary's representative, an authorisation may be required by the Office or, in the context of *inter partes* proceedings, by the other party to those proceedings. In this event, if no authorisation is submitted, the proceedings will continue as if no representative had been appointed. Where the request for registration of the levy of execution is signed by the proprietor's representative who has already been designated as the representative for the CTM in question, the requirements relating to signature and authorisations are fulfilled.

Articles 92(2), 93(1) CTMR

The examination will include whether the recordal applicant (i.e. the CTM proprietor or the beneficiary) is obliged to be represented before the Office (see paragraph 2.4.4 above).

Rule 33(3) CTMIR

The Office will inform the recordal applicant in writing of any deficiencies in the application. If the deficiencies are not remedied within the time limit set in that communication, which will normally be two months following the date of the notification, the Office will reject the request for registration of the levy of execution. The party concerned may file an appeal against this decision. (See Decision 2009-1 of 16 June

2009 of the Presidium of the Boards of Appeal regarding Instructions to Parties in Proceedings before the Boards of Appeal).

Where the request for registration of the levy of execution is submitted by the CTM proprietor alone, the Office will not inform the beneficiary. The examination of evidence of the levy of execution will be done *ex officio*. The Office will disregard any statements or allegations of the beneficiary regarding the existence or scope of the levy of execution or its registration; the beneficiary cannot oppose the registration of a levy of execution.

2.6 Registration procedure and publications

Rules 33(4), 84(5) CTMIR

The levy of execution for CTMAs will be mentioned in the files kept by the Office for the Community trade mark application concerned.

The Office will notify the recordal applicant of the entry of the levy of execution in the files kept by the Office. Where applicable, the CTM applicant will also be notified.

Rule 84(3)(i), Rule 85(2) CTMIR

When the mark is registered, the levy of execution will be published in the Community Trade Marks Bulletin and entered in the Community Trade Marks Register. The Office will inform the recordal applicant of the registration of the levy of execution. Where applicable, the CTM proprietor will also be informed.

Access to this information may be obtained through inspection of files (see the Guidelines, Part E, Register Operations, Section 5, Inspection of Files).

Levies of execution are published in Part C.7. of the Bulletin.

3 Procedure for the Cancellation or Modification of the Registration of a Levy of Execution

Rule 35(1) CTMIR

The registration of a levy of execution will be cancelled or modified at the request of an interested party, that is, the applicant or proprietor of the CTM or the registered beneficiary.

3.1 Competence, languages, submission of the request

Article 133 CTMR
Rule 35(3), (6) and (7) CTMIR

Paragraphs 2.1 and 2.2 above apply.

There is no Office form for registering the cancellation or modification of a levy of execution.

3.2 Person submitting the request

Rule 35(1) CTMIR

The request for the cancellation or modification of the registration of a levy of execution may be submitted by:

- a) the CTM applicant/proprietor and the beneficiary jointly,
- b) the CTM applicant/proprietor, or
- c) the registered beneficiary.

3.2.1 Cancellation of the registration of a levy of execution

Rule 35(4) CTMIR

The request for cancellation of the registration of a levy of execution must be accompanied by evidence establishing that the registered levy of execution no longer exists. This proof comprises the final Court judgment.

Where the registered beneficiary alone submits the request for cancellation, the CTM applicant/proprietor will not be informed of this request. Any observations filed by the proprietor will be forwarded to the beneficiary but will not preclude the cancellation of the registration of the levy of execution. Paragraph 2.4.3.1 above applies *mutatis mutandis*.

Where the registration of several levies of execution has been requested simultaneously, it is possible to cancel one of these registrations individually. In such an event, a new recordal number will be created for the cancelled levy of execution.

3.2.2 Modification of the registration of a levy of execution

Rule 35(6) CTMIR

A levy of execution may be modified upon submission of the corresponding Court judgment showing such a modification.

3.3 Contents of the request

Rule 35 CTMIR

Paragraph 2.4 above applies, except that the data concerning the beneficiary need not be indicated except in the case of a modification of the registered beneficiary's name.

3.4 Fees

3.4.1 Cancellation of the registration of a levy of execution

Article 162(2) CTMR
Rule 35(3) CTMIR
Article 2(24) CTMFR

The request for the cancellation of the registration of a levy of execution is not deemed to have been filed until the required fee of EUR 200 per cancellation is paid (unless the recordal applicant is a Court or Authority, in which case no fee is required, see paragraph 2.3 above). Where several cancellations are requested simultaneously or within the same request, and where the CTM applicant/proprietor and the beneficiary are the same in each case, the fee is limited to a maximum of EUR 1 000.

Once the corresponding fee has been paid, the fee will not be reimbursed if the request is refused or withdrawn.

3.4.2 Modification of the registration of a levy of execution

Rule 35(6) CTMIR

The modification of the registration of a levy of execution is not subject to a fee.

3.5 Examination of the request

3.5.1 Fees

Rule 35(3) CTMIR

Where the required fee for the request for the cancellation of the registration of a levy of execution has not been received, the Office will notify the recordal applicant that the request is deemed not to have been filed.

3.5.2 Examination by the Office

Rule 35(2), (4) CTMIR

Paragraph 2.5.2 applies *mutatis mutandis* to the mandatory elements of the request, even for proof of the levy of execution, to the extent that such proof is required.

The Office will notify the recordal applicant of any deficiency, setting a time limit of two months. If the deficiencies are not remedied, the Office will refuse the request for registering the cancellation or modification.

Rules 35(6), 84(5) CTMIR

The registration of the cancellation or modification of the levy of execution will be communicated to the person who submitted the request; if the request was submitted by the beneficiary, the CTM applicant/CTM proprietor will receive a copy of the communication.

3.6 Registration and publication

Rule 84(3)(s), Rule 85(2) CTMIR

In the case of a registered CTM, the creation, cancellation or modification of a registration of a levy of execution will be entered in the Register of Community Trade Marks and published in the Community Trade Marks Bulletin under C.7.

In the case of a CTM application, the cancellation or modification of the levy of execution will be mentioned in the files of the CTM application concerned. When the registration of the CTM is published, no publications will be made for levies of execution that have been cancelled, and if a levy of execution has been modified, the data as modified will be published under C.7.2.

4 Levy of Execution for Registered Community Designs

Articles 27, 30, 33, Article 51(4) CDR
Articles 24, 26, Article 27(2) CDIR
Annex (18) and (19) CDFR

The legal provisions contained in the CDR, CDIR and CDFR in respect of levies of execution correspond to the respective provisions in the CTMR, CTMIR and CTMFR.

Therefore, both the legal principles and the procedure in respect of the registration, cancellation or modification of trade mark levies of execution apply *mutatis mutandis* to Community designs, except for the following specific procedures.

4.1 Multiple applications for registered Community designs

Article 37 CDR
Article 24(1) CDIR

An application for a registered Community design may be in the form of a multiple application, applying for several designs.

For the purposes of the legal effect of a levy of execution, as well as of the procedure for registering a levy of execution, individual designs contained in a multiple application will be dealt with as if they were separate applications, and the same continues to apply after registration of the designs contained in the multiple application.

In other words, each design contained in a multiple application may be levied independently of the others.

Annex (18), (19) CDFR

The fee of EUR 200 for the registration of a levy of execution or the cancellation of a levy of execution applies per design and not per multiple application. The same is true for the ceiling of EUR 1 000 if multiple requests are submitted.

Example 1

Out of a multiple application for 10 designs, 6 designs are levied, in favour of the same beneficiary. The fee is EUR 1 000 provided that either a single request for registration of these 6 levies of execution is submitted or several requests are submitted on the same day.

Example 2

Out of a multiple application for 10 designs, 5 designs are levied, in favour of the same beneficiary. The registration of a levy of execution is also requested for another design not contained in that multiple application. The fee is EUR 1 000 provided that

- either a single request for registration of these 6 levies of execution is submitted, or several requests are submitted on the same day, and
- the holder of the Community design and the beneficiary are the same in all 6 cases.

5 Levy of Execution for International Trade Marks

The Madrid System allows for the recording of a levy of execution against an international registration (see Rule 20 Common Regulations [under the Madrid Agreement Concerning the International Registration of Marks and the Protocol Relating to that Agreement](#)). For the convenience of the users, the [MM19](#) form is available for requesting that a restriction of the holder's right of disposal be entered in the International Register. The use of this form is strongly recommended to avoid

irregularities. Requests should be submitted either directly to the International Bureau by the holder or to the national IP Office of the recorded holder or to the Office of a contracting party to whom the levy of execution is granted or to the Office of the beneficiary. The request cannot be submitted directly to the International Bureau by the beneficiary. OHIM's own Recordal Application form must not be used.

Detailed information on the recording of levies of execution can be found in Part B, Chapter II, paragraphs 92.01 to 92.04 of the Guide to the International Registration of Marks under the Madrid Agreement and the Madrid Protocol (www.wipo.int/madrid/en/guide). For further information on international trade marks, see the Guidelines, Part M, International Marks.

***GUIDELINES FOR EXAMINATION IN THE
OFFICE FOR HARMONIZATION IN THE
INTERNAL MARKET (TRADE MARKS AND
DESIGNS) ON COMMUNITY TRADE MARKS***

PART E

REGISTER OPERATIONS

SECTION 3

CTMs AS OBJECTS OF PROPERTY

CHAPTER 5

***INSOLVENCY PROCEEDINGS OR SIMILAR
PROCEEDINGS***

Table of Contents

1	Introduction.....	3
1.1	Applicable law	3
1.2	Advantages of the registration of insolvency proceedings.....	4
2	Requirements for a Request for the Registration of Insolvency Proceedings or Similar Proceedings	4
2.1	Application form.....	5
2.2	Languages	5
2.3	Fees	5
2.4	Applicants and mandatory content of the application.....	6
2.4.1	Applicants	6
2.4.2	Mandatory indications concerning the CTM and the liquidator	6
2.4.3	Requirements concerning the person who submits the request – signature, proof of appointment, representation.....	7
2.4.4	Representation	7
2.5	Examination of the request for registration.....	8
2.6	Registration procedure and publications	9
3	Procedure for the Cancellation or Modification of the Registration of Insolvency Proceedings.....	9
3.1	Competence, languages, submission of the request.....	9
3.2	Person submitting the request.....	10
3.2.1	Cancellation of the registration of an insolvency	10
3.2.2	Modification of the registration of an insolvency.....	10
3.3	Contents of the request	10
3.4	Fees	11
3.4.1	Cancellation of the registration of insolvency proceedings	11
3.4.2	Modification of the registration of insolvency proceedings	11
3.5	Examination of the request.....	11
3.6	Registration and publication	11
4	Insolvency Proceedings for International Trade Marks	12

1 Introduction

Articles 16, 21 CTMR
Rules 33, 35 CTMIR
Article 31 CDR
Council Regulation (EC) No 1346/2000 of 29 May 2000 on insolvency proceedings

Both registered Community trade marks (CTMs) and Community trade mark applications (CTMAs) may be affected by insolvency proceedings or similar proceedings.

Both registered Community designs (RCDs) and registered Community design applications may be affected by insolvency proceedings or similar proceedings.

Paragraphs 1 to 3 of this chapter deal with recording insolvency proceedings or similar proceedings against CTMs and CTMAs. The provisions in the CDR and CDIR dealing with insolvency proceedings and similar proceedings concerning designs are identical to the equivalent provisions of the CTMR and CTMIR respectively. Therefore, the following applies *mutatis mutandis* to Community designs. Procedures specific to international trade marks are detailed in paragraph 4 below.

For the purposes of these guidelines ‘**insolvency proceedings**’ are understood as the collective proceedings which entail the partial or total divestment of a debtor and the appointment of a liquidator. In the United Kingdom, for example, such proceedings include the winding up by or subject to the supervision of the court, creditors’ voluntary winding up (with confirmation by the court), administration, voluntary arrangements under insolvency legislation and bankruptcy or sequestration; ‘**liquidator**’ is understood as any person or body whose function is to administer or liquidate assets of which the debtor has been divested or to supervise the administration of their affairs. In the United Kingdom, for example, such persons or bodies include liquidators, supervisors of a voluntary arrangement, administrators, official receivers, trustees and judicial factors; ‘**Court**’ is understood as the judicial body or any other competent body of a Member State empowered to open insolvency proceedings or to take decisions in the course of such proceedings; ‘**judgment**’ in relation to the opening of insolvency proceedings or the appointment of a liquidator is understood as including the decision of any Court empowered to open such proceedings or to appoint a liquidator (for terminology in other territories, please see Council Regulation (EC) No 1346/2000 of 29 May 2000 on insolvency proceedings).

1.1 Applicable law

These guidelines serve to explain the procedure before the Office for registering the opening, modification or closure of insolvency proceedings or similar proceedings. In accordance with Article 16 CTMR, all other provisions are covered by national law. In addition, Council Regulation (EC) No 1346/2000 of 29 May 2000 on insolvency proceedings regulates the provisions on jurisdiction, recognition and applicable law in the area of insolvency proceedings.

Article 21(1) CTMR

The Regulations specifically state that a Community trade mark may only be involved in insolvency proceedings opened in the Member State in the territory of which the debtor has its centre of main interests, the only exception being when the debtor is an insurance undertaking or credit institution in which case the Community trade mark may only be involved in those proceedings opened in the Member State where that undertaking or institution has been authorised. The '**centre of main interests**' should correspond to the place where the debtor conducts the administration of its interests on a regular basis and is, therefore, ascertainable by third parties.

1.2 Advantages of the registration of insolvency proceedings

Articles 21(3), 23(4) CTMR

Registration of the opening, modification and closure of insolvency proceedings is not compulsory, however, such a registration has particular advantages.

- a) In view of the provision of Article 23(4) CTMR, vis-à-vis third parties who might have acquired or have entered in the Register rights in the trade mark which are incompatible with the registered insolvency, the effects shall be governed by the law of the Member State in which such proceedings are first brought within the meaning of national law or of conventions applicable in this field.
- b) In the event that insolvency proceedings against a Community trade mark are entered in the Register, the CTM proprietor loses its right to act and, therefore, may not perform any actions before the Office (such as withdraw, surrender, transfer, file oppositions, act in *inter partes* proceedings, etc.).
- c) In the event that insolvency proceedings against a Community trade mark are entered in the Register, the Office will notify the liquidator at least six months before the expiry of the registration that the registration is approaching expiry. The Office will also notify the liquidator of any loss of rights and of the expiry of the registration, where applicable.
- d) Recording insolvency proceedings is important for maintaining the veracity of the Register, particularly in the event of *inter partes* proceedings. In this respect please see the Guidelines, Part C, Opposition, Section 1, Procedural Matters, paragraph 6.5.5.2.

The Office strongly recommends that liquidators withdraw, surrender or transfer the CTMs and CTMAs subject to insolvency proceedings prior to the final winding up.

2 Requirements for a Request for the Registration of Insolvency Proceedings or Similar Proceedings

Article 21(3), Article 24 CTMR
Rule 33, Rule 84(3)(i) CTMIR

Both CTMAs and CTMs may be the subject of the registration of insolvency proceedings.

The application for registration of insolvency proceedings must comply with the following conditions.

2.1 Application form

Rule 95(a) and (b) CTMIR

The application must be a formal request for registering insolvency proceedings or similar proceedings.

It is strongly recommended that the request for registration of insolvency proceedings against a CTM be submitted on the Recordal Application form using the 'others' option in the 'Type of recordal' section of the form. This form is available free of charge in the official languages of the European Union. It can be downloaded from OHIM's website.

Any language version of this form may be used, provided that it is completed in one of the languages referred to in paragraph 2.2 below.

2.2 Languages

Rule 95(a) CTMIR

The application for the registration of insolvency proceedings against a CTMA may be submitted in the first or second language of the CTM application.

Rule 95(b) CTMIR

The application for the registration of insolvency proceedings against a CTM must be submitted in one of the five languages of the Office, namely, English, French, German, Italian or Spanish.

2.3 Fees

Article 162(2)(c) and (d) CTMR
Rule 33(1) and (4) CTMIR
Article 2(23) CTMFR

There is no fee for registering insolvency proceedings or similar proceedings.

2.4 Applicants and mandatory content of the application

2.4.1 Applicants

Article 20(3) CTMR

The registration of insolvency proceedings or similar proceedings may be requested by:

- a) the liquidator,
- b) the Court,
- c) the applicant/owner/holder.

2.4.2 Mandatory indications concerning the CTM and the liquidator

Rule 31, Rule 33(1) CTMIR

The request for registration of insolvency proceedings or similar proceedings must contain the following information.

Article 21(2) CTMR
Rule 31(1)(a), Rule 33(1) CTMIR

- a) The registration number of the CTM concerned.

Where the recordal applicant indicates only some of the CTMs owned by the proprietor, the Office will register the insolvency proceedings against all CTMs and CTMAs linked to the owner's ID number at the Office.

Where the owner is joint proprietor of a CTM or CTMA, the insolvency proceedings will apply to the share of the joint proprietor.

Rules 1(1)(b), 31(1)(b), Rule 33(1) CTMIR

- b) The liquidator's name, address and nationality and the State in which it is domiciled or has its seat or an establishment.

Rule 1(1)(e), Rules 31(2), 33(1) CTMIR

- c) If the liquidator designates a representative, the representative's name and business address must be indicated; the indication of the address may be replaced by the indication of the ID number allocated by the Office.

2.4.3 Requirements concerning the person who submits the request – signature, proof of appointment, representation

Rule 79, Rule 82(3) CTMIR

Where the requirement of a signature is referred to, pursuant to Rule 79 and Rule 82(3) CTMIR, in electronic communications, the indication of the sender's name will be deemed equivalent to the signature.

There is sufficient proof of the appointment of a liquidator and of the insolvency proceedings if the request for registration of the insolvency proceedings is accompanied by the Court judgment.

It suffices if the insolvency judgment is submitted. In many instances, the parties to the insolvency proceedings will not wish to disclose all the details of the judgment, which may contain confidential information. In these cases it suffices if only a part or an extract of the judgment is submitted, as long as it identifies the parties to the proceedings. All other elements may be omitted or blacked out.

Original documents become part of the file and, therefore, cannot be returned to the person who submitted them. Simple photocopies are sufficient. The original or photocopy does not need to be authenticated or legalised unless the Office has reasonable doubts as to the veracity of the documents.

Rule 95(a) and (b), Rule 96(2) CTMIR

The evidence of the insolvency proceedings must be:

- a) in the language of the Office which has become the language of the proceedings for the registration of the insolvency, see paragraph 2.2 above.
- b) in any official language of the European Union other than the language of the proceedings; in this case the Office may require a translation of the document into a language of the Office to be filed within a period specified by the Office.

Where the supporting documents are not submitted in either an official language of the European Union or in the language of the proceedings, the Office may require a translation into the language of the proceedings or, at the choice of the party requesting the registration of the insolvency, in any language of the Office. The Office will set a time limit of two months from the date of notification of that communication. If the translation is not submitted within that time limit, the document will not be taken into account and will be deemed not to have been submitted.

2.4.4 Representation

Articles 92(2), 93(1) CTMR

The general rules on representation apply (see the Guidelines, Part A, General Rules, Section 5, Professional Representation).

2.5 Examination of the request for registration

Article 21(1) CTMIR

The Office will check that there are no other pending records and that no insolvency proceedings have already been registered for the proprietor concerned. Only a request relating to the Member State in which insolvency proceedings or similar proceedings were first brought may be recorded.

Rule 33(3) CTMIR

The Office will check whether the request for registration of the insolvency proceedings complies with the formal conditions mentioned in paragraph 2.4 above (indication of the CTM number(s), the required information concerning the liquidator, the liquidator's representative where applicable).

The validity of the insolvency judgment will not be examined.

Article 93(1) CTMR Rules 33, 76, 77 CTMIR

The Office will check whether the request for registration of the insolvency proceedings has been duly signed. Where the request is signed by the liquidator's representative, an authorisation may be required by the Office or, in the context of *inter partes* proceedings, by the other party to those proceedings. In this event, if no authorisation is submitted, the proceedings will continue as if no representative had been appointed.

Articles 92(2), 93(1) CTMR

The examination will include whether the recordal applicant (i.e. the liquidator, the Court or the applicant/proprietor/holder) is obliged to be represented before the Office (see paragraph 2.4.4 above).

Rule 33(3) CTMIR

The Office will inform the recordal applicant in writing of any deficiencies in the application. If the deficiencies are not remedied within the time limit set in that communication, which will normally be two months following the date of the notification, the Office will reject the request for registration of the insolvency proceedings. The party concerned may file an appeal against this decision. (See Decision 2009-1 of 16 June 2009 of the Presidium of the Boards of Appeal regarding Instructions to Parties in Proceedings before the Boards of Appeal).

2.6 Registration procedure and publications

Rule 33(4), 84(5) CTMIR

The insolvency proceedings for CTMAs will be mentioned in the files kept by the Office for the Community trade mark application(s) concerned.

The Office will notify the recordal applicant of the entry of the insolvency proceedings in the files kept by the Office. Where applicable, the CTM applicant will also be notified.

Rule 84(3)(i), Rule 85(2) CTMIR

When the mark is registered, the insolvency proceedings will be published in the Community Trade Marks Bulletin and entered in the Community Trade Mark Register. The Office will inform the recordal applicant of the registration of the insolvency proceedings.

The liquidator's contact details are recorded as the proprietor's 'correspondence address' in OHIM's owners and representatives database and third parties may consult the full details of the insolvency proceedings through an application for inspection of files (see the Guidelines, Part E, Register Operations, Section 5, Inspection of Files).

Insolvency proceedings are published in part C.6. of the Bulletin. The publication contains the CTM registration number(s), the name of the authority requesting the entry in the Register, the date and number of the entry and the publication date of the entry in the CTM Bulletin.

3 Procedure for the Cancellation or Modification of the Registration of Insolvency Proceedings

Rule 35(1) CTMIR

The registration of insolvency proceedings will be cancelled or modified at the request of an interested party, that is, the applicant or proprietor of the CTM or the registered liquidator.

3.1 Competence, languages, submission of the request

Article 133 CTMR
Rules 35(3), (6), (7) CTMIR

Paragraphs 2.1 and 2.2 above apply.

There is no Office form for registering the cancellation or modification of insolvency proceedings.

3.2 Person submitting the request

Rule 35(1) CTMIR

The request for the cancellation or modification of the registration of insolvency proceedings may be submitted by:

- a) the registered liquidator,
- b) the Court,
- c) the applicant/owner/holder.

3.2.1 Cancellation of the registration of an insolvency

Rule 35(4) CTMIR

The request for registering the cancellation of insolvency proceedings must be accompanied by evidence establishing that the registered insolvency no longer exists. This proof comprises the final Court judgment.

Where the registered liquidator alone submits the request for cancellation, the CTM applicant/proprietor will not be informed of this request. Any observations filed by the proprietor will be forwarded to the liquidator but will not preclude the cancellation of the registration of the insolvency proceedings.

3.2.2 Modification of the registration of an insolvency

Rule 35(6) CTMIR

The registration of insolvency proceedings may be modified upon submission of the corresponding Court judgment showing such a modification.

3.3 Contents of the request

Rule 35 CTMIR

Paragraph 2.4 above applies, except that the data concerning the liquidator need not be indicated except in the event of a modification of the registered liquidator's name.

3.4 Fees

3.4.1 Cancellation of the registration of insolvency proceedings

Article 162(2) CTMR
Rule 35(3) CTMIR
Article 2(24) CTMFR

The request for the cancellation of the registration of insolvency proceedings is not subject to a fee.

3.4.2 Modification of the registration of insolvency proceedings

Rule 35(6) CTMIR

The modification of the registration of insolvency proceedings is not subject to a fee.

3.5 Examination of the request

Rule 35(2), (4) CTMIR

Paragraph 2.5 applies *mutatis mutandis* to the mandatory elements of the request, even for proof of the insolvency proceedings.

The Office will notify the recordal applicant of any deficiency, setting a time limit of two months. If the deficiencies are not remedied, the Office will refuse the request for registering the cancellation or modification.

Rules 35(6), 84(5) CTMIR

The registration of the cancellation or modification of the insolvency proceedings will be communicated to the person who submitted the request; if the request was submitted by the liquidator, the CTM applicant/proprietor will receive a copy of the communication.

3.6 Registration and publication

Rule 84(3)(s), Rule 85(2) CTMIR

In the case of a registered CTM, the creation, cancellation or modification of a registration of an insolvency will be entered in the Register of Community Trade Marks and published in the Community Trade Marks Bulletin under C.6.

In the case of a CTM application, the cancellation or modification of the insolvency proceedings will be mentioned in the files of the CTM application concerned. When the registration of the CTM is published, no publications will be made for insolvency

proceedings that have been cancelled, and if the insolvency proceedings have been modified, the data as modified will be published under C.6.2.

4 Insolvency Proceedings for International Trade Marks

The Madrid System allows for the recording of insolvency proceedings against an international registration (see Rule 20 Common Regulations [under the Madrid Agreement Concerning the International Registration of Marks and the Protocol Relating to that Agreement](#)). For the convenience of the users, the MM19 form is available for requesting that a restriction of the holder's right of disposal be entered in the International Register. The use of this form is strongly recommended to avoid irregularities. Requests should be submitted either directly to the International Bureau by the holder or to the national IP Office of the recorded holder or to the Office of a contracting party in respect of whom the insolvency is granted or to the Office of the liquidator. The request cannot be submitted directly to the International Bureau by the liquidator. OHIM's own Recordal Application form must not be used.

Detailed information on the recording of insolvency proceedings can be found in Part B, Chapter II, paragraphs 92.01 to 92.04 of the Guide to the International Registration of Marks under the Madrid Agreement and the Madrid Protocol (www.wipo.int/madrid/en/guide). For further information on international trade marks, see the Guidelines, Part M, International Marks.

***GUIDELINES FOR EXAMINATION IN THE
OFFICE FOR HARMONIZATION IN THE
INTERNAL MARKET (TRADE MARKS AND
DESIGNS) ON COMMUNITY TRADE MARKS***

PART M

INTERNATIONAL MARKS

Table of Contents

1	Introduction.....	4
2	OHIM as Office of Origin	4
2.1	Examination and forwarding of international applications.....	4
2.1.1	Identification of international applications.....	4
2.1.2	Fees.....	5
2.1.2.1	Handling fee.....	5
2.1.2.2	International fees.....	5
2.1.3	Forms.....	6
2.1.3.1	Entitlement to file.....	7
2.1.3.2	Basic mark.....	7
2.1.3.3	Priority claim(s).....	9
2.1.3.4	Designated contracting parties.....	9
2.1.3.5	Signature.....	9
2.1.3.6	Form for the designation of the USA.....	9
2.1.4	Examination of the international application by OHIM.....	10
2.1.5	Irregularities found by WIPO.....	10
2.2	Subsequent designations	11
2.3	Notification of facts affecting the basic registration.....	12
2.4	Forwarding of changes affecting the international mark.....	13
2.4.1	Cases where applications for changes can be forwarded without examination.....	14
2.4.2	Cases where applications for changes will be forwarded after examination.....	14
3	OHIM as Designated Office.....	15
3.1	Overview	15
3.2	Professional representation	16
3.3	First republication, searches and formalities.....	16
3.3.1	First republication.....	16
3.3.2	Searches.....	17
3.3.3	Formalities examination.....	17
3.3.3.1	Languages.....	17
3.3.3.2	Collective marks.....	18
3.3.3.3	Seniority claims.....	19
3.3.3.4	Vague terms.....	21
3.4	Absolute grounds for refusal.....	22
3.5	Third-party observations	23
3.6	Opposition	23
3.6.1	Timing.....	23
3.6.2	Receipt and informing the international holder.....	24
3.6.3	Fees.....	24
3.6.4	Admissibility check.....	24
3.6.5	Language of proceedings.....	25
3.6.6	Representation of the IR holder.....	25
3.6.6.1	Opposition receipts.....	25
3.6.6.2	Notification of commencement of opposition proceedings.....	25
3.6.7	Provisional refusal (based on relative grounds).....	26

3.6.8	Suspension of opposition where there is a pending provisional refusal on the specification of goods and services and/or absolute grounds.....	26
3.7	Cancellation of the IR or renunciation of the EU designation	27
3.8	Limitations of the list of goods and services	27
3.9	Confirmation or withdrawal of provisional refusal and issue of Statement of Grant of Protection	28
3.10	Second republication	28
3.11	Transfer of the designation of the EU	29
3.12	Invalidity, revocation and counterclaims.....	29
3.13	Fee management.....	30
4	Conversion, Transformation, Replacement	30
4.1	Preliminary remarks	30
4.2	Conversion.....	31
4.3	Transformation	31
4.3.1	Preliminary remarks.....	31
4.3.2	Principle and effects	32
4.3.3	Procedure	32
4.3.4	Examination.....	33
4.3.4.1	Application for transformation of IR designating the EU where no particulars have been published.....	33
4.3.4.2	Application for transformation of IR designating the EU where particulars have been published.....	33
4.3.5	Transformation and Seniority	34
4.3.6	Fees.....	34
4.4	Replacement.....	34
4.4.1	Preliminary remarks.....	34
4.4.2	Principle and effects	35
4.4.3	Procedure	35
4.4.4	Fees.....	36
4.4.5	Publication	36
4.4.6	Replacement and seniority.....	36
4.4.7	Replacement and transformation	36
4.4.8	Replacement and conversion	36

This part of the Guidelines focuses specifically on the examination of international marks. For further details on normal aspects of procedure, please also consult the other relevant parts of the Guidelines (examination, opposition, cancellation, etc.).

1 Introduction

The purpose of this part of the Guidelines is to explain how, in practice, the link between the Community trade mark (CTM) and the Protocol Relating to the Madrid Agreement Concerning the International Registration of Marks ('Madrid Protocol' or MP) affects procedures and standards of examination and opposition at OHIM. Paragraph 2 deals with OHIM's tasks as an office of origin, that is, with 'outgoing' international applications. Paragraph 3 deals with its tasks as a designated office, that is, with 'incoming' international registrations designating the EU (IR). Paragraph 4 deals with conversion, transformation and replacement.

The Guidelines are not intended to, and cannot, add to or subtract from the substance of new Title XIII CTMR and Rules 102-126 CTMIR. OHIM is also bound by the provisions of the Madrid Protocol and the Common Regulations (CR). Reference may also be made to the 'Guide to the International Registration of Marks' published by WIPO as the Guidelines do not intend to repeat what is said there.

2 OHIM as Office of Origin

The tasks of OHIM as office of origin chiefly comprise:

- examining and forwarding international applications;
- examining and forwarding subsequent designations;
- handling notices of irregularity issued by WIPO;
- notifying WIPO of certain facts affecting the basic mark during the five-year dependency period;
- forwarding certain requests for changes in the international register.

2.1 Examination and forwarding of international applications

Article 146 CTMR Rule 102(3) CTMIR

International applications filed with OHIM are subject to:

- payment of the handling fee;
- the existence of (a) basic CTM registration(s) or application(s) ('basic mark(s)');
- identity between the international application and the basic mark(s);
- proper completion of the MM2 or EM2 form;
- an entitlement to file the international application through OHIM.

2.1.1 Identification of international applications

An international application will be identified in the OHIM database under the basic CTM(A) number followed by the suffix **_01** (e.g. 012345678_01) if it relates to a first

international application. Further applications based on the same basic CTM(A) will be identified by **_02**, **_03**, etc. International applications based on more than one CTM(A) will be identified by the number of the older CTM(A).

Upon receipt of an international application, the examiner will send a receipt to the applicant, quoting the file number.

2.1.2 Fees

2.1.2.1 Handling fee

Article 147(5), Article 150 CTMR
Article 2(31) CTMFR
Rule 103(1), Rule 104 CTMIR

An international application is only deemed to have been filed if the handling fee of EUR 300 has been paid.

Payment of the handling fee must be made to OHIM by one of the accepted means of payment (for details, see the Guidelines Part A, General Rules, Section 3, Payment of Fees, Costs and Charges, paragraph 2, Means of Payment).

Where the applicant chooses to base the international application on a CTM once it is registered, the application for the IR is deemed to have been received on the date of registration of the CTM; therefore, the handling fee will be due on the date of registration of the CTM.

The means of payment used may be communicated to OHIM by ticking the appropriate boxes on the EM2 form or by giving this information in the letter accompanying the MM2 form.

If, in the course of examination of the international application, the examiner finds that the handling fee has not been paid, the examiner will inform the applicant and ask it to pay the fee within two months. If payment is made within the two-month time limit set by the OHIM, the date of receipt which OHIM will communicate to WIPO will be the date the payment reaches OHIM. If payment is still not made within the two-month time limit set by OHIM, OHIM will inform the applicant that it considers the international application not to have been filed and will close the file.

2.1.2.2 International fees

All international fees must be paid directly to WIPO. None of the fees payable directly to WIPO will be collected by OHIM. Any such fees paid by error to OHIM will be reimbursed to the sender.

If the applicant uses EM2 forms, the Fee Calculation Sheet (Annex to WIPO form MM2) must be submitted in the language in which the international application is to be transmitted to WIPO. Alternatively, the applicant can attach a copy of the payment to WIPO. However, OHIM will not examine whether the Fee Calculation Sheet is attached, whether it is correctly filled in, or whether the amount of the international fees has been correctly calculated. Any questions regarding the amount of the international

fees and related means of payment should be addressed to WIPO. A fee calculator is available on WIPO's website.

2.1.3 Forms

Article 147(1) CTMR Rules 83(2)(b), 103(2)(a) CTMIR
--

Use of one of the official forms is compulsory. The official form is either WIPO form MM2, available in English, French or Spanish, or OHIM form EM2 (OHIM adaptation of MM2), which is available in all official EU languages. Applicants may not use other forms or change the contents and layout of the forms. However, both the WIPO MM2 form and the OHIM EM2 form are available in .doc format allowing as much text as necessary to be entered for each item.

If the application is filed in a language that is not one of the Madrid Protocol languages (English, French, Spanish), the applicant must indicate in which of these three languages the application is to be forwarded to WIPO. All items on the form must be completed in the same language; it is not possible to choose a language other than the language of the form.

OHIM recommends using the OHIM EM2 form. The OHIM EM2 form in English, French and Spanish has almost the same layout and numbering as the WIPO MM2 form but is specifically adapted to the CTM environment:

- applicants can indicate payment details (item 0.4) to OHIM in the introductory item 0 and the number of pages (item 0.5) the application contains;
- certain choices are limited to what is applicable to OHIM (e.g. OHIM is always the office of origin (item 1), and the applicant must be a national of an EU Member State (item 3));
- item 4b has been added for including the representative before OHIM;
- the reproduction of the mark need not be submitted in item 7, as OHIM will use the reproduction available in the basic CTM(A);
- the option of seeking protection for the same goods and services contained in the basic mark by ticking a box has been added in item 10;
- since self-designation is not possible, the EU is not included in the list of Contracting Parties to be designated in item 11;
- item 13 has been deleted, as OHIM certifies the international application electronically.

Where the applicant chooses the OHIM EM2 form in a language version other than English, French or Spanish, the following additional sections of the form have to be completed:

- tick boxes in item 0.1 for indicating the MP language in which the international application is to be transmitted to WIPO;
- tick boxes in item 0.2 for selecting the language in which OHIM is to communicate with the applicant on matters concerning the international application, that is, either the language in which the international application is filed or the language in which it is to be transmitted to WIPO (see Article 147(1), second sentence, CTMR);

- tick boxes in item 0.3 for indicating either that a translation of the list of goods and services is included or that OHIM is authorised to produce the translation;
- a final item A with tick boxes for specifying annexes (attached translations).

The appropriate boxes in items 0.1, 0.2 and 0.3 must be ticked. If none of the boxes in item 0.2 is ticked, OHIM will communicate with the applicant in the language of the EM2 form.

All applicable items in the form must be completed following the indications provided on the form itself and in the 'Guide to the International Registration of Marks' published by WIPO.

2.1.3.1 Entitlement to file

Article 2(1)(i) Madrid Protocol (MP)

Under item 3 of the official form, an indication must be given regarding entitlement to file. An applicant is entitled to file with OHIM as office of origin if it is a national of, or has domicile or a real and effective industrial or commercial establishment in, an EU Member State. The applicant may choose on which criterion/criteria to base the right to file. For example, a Danish national domiciled in Germany can choose to base entitlement to file either on nationality or domicile. A French national domiciled in Switzerland is entitled to file only based on nationality (however, in this case a representative before OHIM must be appointed). A Swiss company with no domicile or real and effective industrial or commercial establishment in an EU Member State is not entitled to file an international application through OHIM.

Where there are multiple applicants, each must fulfil at least one of the entitlement criteria.

The expression 'real and effective industrial or commercial establishment in an EU Member State' is to be interpreted in the same way as in other instances, such as in the context of professional representation (see the Guidelines, Part A, General Rules, Section 5, Professional Representation, paragraph 3.1.1).

2.1.3.2 Basic mark

Rule 103(2)(c), (d), (e) CTMIR Rule 9(4)(a)(v), (vii), (vii bis-xii), Rule 11(2) CR
--

The Madrid system is founded on the requirement of a basic national or regional trade mark application or registration. Under the MP, an international application may be based on either a mark that has already been registered ('basic registration'), or a trade mark application ('basic application') at any point in the trade mark examination procedure.

An applicant may choose to base its international application on several basic marks providing it is the applicant/proprietor of all the basic CTMAs and CTMs even where, although containing identical marks, the goods and services covered are different.

All the basic CTMA(s) or CTM(s) must have been accorded a filing date, and must be in force.

The international applicant must be identical to the CTM holder/CTMA applicant. The international application may not be filed by a licensee or an affiliated company of the holder of the basic mark(s). A deficiency in this respect may be overcome by transferring the basic mark to the international application applicant, or by recording a change of name, as applicable (see the Guidelines Part E, Register Operations, Section 3, CTMs as Objects of Property, Chapter 1, Transfer). Where there are multiple holders or applicants in the basic CTM(s) or CTMA(s), the international application must be submitted by the same persons.

The reproduction of the mark must be identical. For full details of the Office practice in relation to the identity of trade marks filed in black and white and/or greyscale as compared to those filed in colour please see Part B Section 2 Formalities, paragraph 14.2.1, in relation to priority claims which applies by analogy. Particular attention should be paid to the following:

- Item 7 c) of the official form must be ticked if the mark is in standard characters (word mark).
- Item 8 a) of the official form foresees the possibility of making a colour claim. Where the basic CTM(s) or CTMA(s) contain(s) an indication of colours, the same indication must be made in the international application (see the Guidelines, Part B, Examination, Section 2, Formalities, paragraph 11). Where the basic CTM(s) or CTMA(s) is/are in colour but do(es) not contain an indication of colours the applicant may choose to indicate the colours for the international application.
- If the basic mark is
 - a mark for a colour or colour combination as such,
 - a three-dimensional mark,
 - a sound mark, and/or
 - a collective mark,

the international application must be the same, and item 7 d) or 9 d) must be ticked. If the basic mark is a sound mark, only the graphic representation, for example, the musical notation will be transmitted to WIPO as WIPO does not accept electronic sound files.

- If the basic mark includes a description, the same description may be included in the international application (item 9 e)). However, a description of the mark may not be added in the international application if the basic mark(s) do(es) not contain one.
- A disclaimer may be included even if the basic mark(s) do(es) not include one (item 9 g)).
- WIPO requires a transliteration in Latin characters if the mark contains characters other than Latin. If no transliteration is provided, WIPO will raise an irregularity, which must be remedied directly by the applicant. This is true for all types of trade marks, not just word marks.

The list of goods and services must be identical to or narrower than the list contained in the basic mark(s) on the day the international application is filed.

- The applicant must specify the list of goods and services by class (item 10).
- The list may also be limited for some designated parties.

If the applicant does not provide a translation into the WIPO language chosen by it (English, French or Spanish) but instead authorises OHIM to provide the translation or to use the one available for the basic mark(s), it will not be consulted on the translation.

2.1.3.3 Priority claim(s)

If priority is claimed under item 6 of the official form, the office of earlier filing, the filing number (if available) and the filing date must be indicated. Priority documents should not be submitted. Where the earlier filing claimed as a priority right in an international application does not relate to all the goods and services, those to which it does relate should be indicated. Where priority is claimed from several earlier filings with different dates, the goods and services to which each earlier filing relates should be indicated. The validity of the claim will in principle not be challenged by the examiner, as in most cases either the basic CTM(A) is the first filing for which priority is claimed or the priority of another earlier mark has already been claimed and examined in relation to the basic CTM(A). However, if there is evidence in the file that priority is claimed for a right that is not a first filing, the examiner will object and request that the priority claim be deleted.

2.1.3.4 Designated contracting parties

An international application filed at OHIM is governed exclusively by the Madrid Protocol. Only contracting parties that are party to the Protocol can be designated, regardless of whether they are also bound by the Madrid Agreement.

2.1.3.5 Signature

Rule 9(2)(b) CR

The signature in item 12 of the official form is optional since the data will be forwarded only electronically to WIPO and not as an original document or facsimile copy of the form.

2.1.3.6 Form for the designation of the USA

Where the United States of America is designated, a duly completed and signed WIPO MM18 form must be attached (see item 11, footnote **). This form, which contains the declaration of intention to use the mark, is available only in English and must be submitted in that language irrespective of the language of the international application.

2.1.4 Examination of the international application by OHIM

Article 147 CTMR Rule 103(2), Rule 104 CTMIR Article 3(1) MP
--

Where examination of the international application reveals deficiencies, OHIM will invite the applicant to remedy them within one month. In principle, this short time limit should enable OHIM to forward the international application to WIPO within two months from the date of receipt and thus maintain that date as the date of international registration.

Examiners may try solving minor deficiencies or seeking clarification over the phone in order to speed up the process.

If the deficiencies are not remedied, OHIM will inform the applicant that it refuses to forward the international application to WIPO. The handling fee will not be refunded.

This does not preclude the filing of another international application at a later date.

As soon as OHIM is satisfied that the international application is in order, it will transmit it to WIPO electronically, with the exception of documents such as the Fee Calculation Sheet or the MM18, which will be transmitted as scanned attachments. The electronic transmission will contain the certification by the office of origin referred to in Article 3(1) MP.

2.1.5 Irregularities found by WIPO

Rule 11(4), Rules 12, 13 CR

If WIPO detects irregularities in the application, it will issue an irregularity notice, which will be forwarded to both the applicant and OHIM as office of origin. The irregularities must be remedied by OHIM or the applicant, depending on their nature. Irregularities relating to the payment of the international fees must be remedied by the applicant. Any of the irregularities mentioned in Rule 11(4) CR must be remedied by OHIM.

Where there are irregularities in the classification of the goods and services, in the indication of the goods and services, or in both, the applicant cannot present its arguments directly to WIPO. Instead, they must be communicated through OHIM. In this case, OHIM will forward the applicant's communication just as it is to WIPO, as OHIM does not make use of either the option under Rule 12(2) CR to express a different opinion or that under Rule 13(2) CR to make a proposal to remedy the irregularity.

2.2 Subsequent designations

Article 149 CTMR
Rule 1(xxvi bis), Rule 24(2) CR
Article 2(1)(ii) MP
Rule 83(2)(b), Rule 105(1)(a), (c), (d), Rule 105(2), (4) CTMIR

Within the framework of the Madrid System, the holder of an international registration can extend the geographical scope of a registration's protection. There is a specific procedure called 'subsequent designation to a registration', which extends the scope of the international registration to other members of the Madrid Union for whom either no designation has been recorded to date or the prior designation is no longer in effect.

Unlike international applications, subsequent designations need not be filed through the office of origin but may be filed directly with WIPO. Direct filing with WIPO is recommended for a speedier process.

Where an IR is transferred to a person who is not entitled to make a subsequent designation through OHIM, the application for such a subsequent designation cannot be filed through OHIM, but must instead be filed through WIPO or the corresponding office of origin (for more information on entitlement to file, see paragraph 2.1.3.1 above).

Subsequent designations may only be made after an initial international application has been made and has resulted in an international registration.

Subsequent designations are not subject to payment of a handling fee to OHIM.

Subsequent designations must be filed on the official form: the WIPO MM4 form in English, French or Spanish or the OHIM EM4 form in the other EU languages. There is no specific OHIM form in English, French and Spanish as no special indications for OHIM are needed in those languages and the WIPO MM4 form is, therefore, sufficient.

The Fee Calculation Sheet (Annex to the WIPO MM4 form) must be submitted in the language in which the subsequent designation is to be transmitted to WIPO. Alternatively, the applicant can attach a copy of the payment to WIPO. However, OHIM will not examine whether the Fee Calculation Sheet is attached, whether it is correctly filled in, or whether the amount of the international fees has been correctly calculated. Any questions regarding the amount of the international fees and related means of payment should be addressed to the International Bureau. A fee calculator is available on WIPO's website.

In the MM4 or EM4 forms, the indications to be made are limited to indications concerning the applicant and its entitlement to file, indications concerning the representative, the list of goods and services, and the designation of additional Contracting Parties to the Madrid Protocol. These indications must be made in the same way as in the MM2 form. The only difference in the entitlement to file is that a subsequent designation may be filed at OHIM if the international registration is transferred to a person who is a national of an EU Member State or has their domicile or an establishment in the EU (OHIM as 'office of the contracting party of the holder').

A subsequent designation may also be used to extend the scope of the IR to enlarge the goods and/or services coverage of a prior designation

The list of goods and services may be the same as in the international registration (item 5 a) of the official form) or narrower (item 5 b) or c)). It may not be broader than the scope of protection of the international registration even if covered by the basic mark.

For example, an IR for classes 18 and 25 designating China for class 25 can subsequently be extended to China for class 18; however, that same IR could not be subsequently extended to China for class 9 as this class is not covered by the international registration, even if it is covered by the basic mark.

Within these limitations, different lists may be presented for different, subsequently designated, contracting parties.

The mark must be the same as in the initial international registration.

Subsequent designations must be made in the same language as the initial international application, failing which OHIM will refuse to forward the subsequent designation.

If the application is not in English, French or Spanish, the applicant must tick item 0.1 on the OHIM EM4 form and indicate the language in which the subsequent designation is to be transmitted to WIPO. That language may be different from the language of the international registration. Items 0.2 and 0.3 regarding the translation of the list of goods and services and the language of correspondence between the applicant and OHIM must also be completed.

Where the holder/applicant so requests, a subsequent designation may take effect after specific proceedings have been concluded, namely the recording of a change or a cancellation in respect of the IR concerned or the renewal of the IR.

2.3 Notification of facts affecting the basic registration

Articles 44, 49 CTMR Rule 106(1)(a), (b), (c), Rule 106(2), (3), (4) CTMIR

If, within five years of the date of the international registration, the basic mark(s) ceases to exist in whole or in part, the international registration is cancelled to the same extent since it is 'dependent' thereon. This occurs not only in the event of a 'central attack' by a third party, but also if the basic mark(s) lapse(s) due to action or inaction on the part of its proprietor.

For CTMs, this covers cases where, either fully or partially (for only some goods or services),

- the CTMA(s) on which the IR is based is (are) withdrawn, deemed to be withdrawn or refused;
- the CTM(s) on which the IR is based is (are) surrendered, not renewed, revoked or declared invalid by OHIM or, upon a counterclaim in infringement proceedings, by a CTM court.

Where the above occurs as a result of a decision (by OHIM or a CTM court), the decision must be final.

If the above occurs within the five-year period, OHIM must notify WIPO accordingly.

OHIM must check that the international application has actually been registered before notifying WIPO that the basic CTM has ceased to have effect.

WIPO must also be notified in certain cases where a procedure has been initiated prior to expiry of the five-year period but is not finally decided within that period. This notification is to be made immediately after expiry of the five-year period. The cases involved are:

- a pending refusal of the basic CTMA(s) on absolute grounds (including ensuing appeals before the Boards of Appeal or the GC/CJEU);
- pending opposition proceedings (including ensuing appeals before the Boards or the GC/CJEU);
- pending cancellation proceedings before OHIM (including ensuing appeals before the Boards or the GC/CJEU);
- a counterclaim in infringement proceedings against a CTM, according to the CTM Register, which is pending before a CTM court.

Once a final decision has been taken or the proceedings have been terminated, a further notification must be sent to WIPO stating whether and to what extent the basic mark(s) has (have) ceased to exist or remained valid.

If, within five years of the date of the international registration, the basic CTM(s) or CTMA(s) is (are) divided or partially transferred, this must also be notified to WIPO. However, in those cases, there will be no effect on the validity of the international registration. The purpose of the notification is merely to keep record of the number of mark(s) on which the IR is based.

No other changes in the basic mark(s) will be notified to WIPO by OHIM. Where the applicant/holder wishes to record the same changes in the international register it should apply for this separately (see paragraph 2.4 below)

2.4 Forwarding of changes affecting the international mark

Rule 107 CTMIR

The international register is kept at WIPO. The possible changes listed below may only be recorded once the mark has been registered.

OHIM will not process requests for renewal or payments of renewal fees.

In principle, most changes relating to international registrations can be filed either directly with WIPO by the holder of the international registration on record or through the office of origin. However, some applications for changes can be filed by another party and through another office, as detailed below.

2.4.1 Cases where applications for changes can be forwarded **without** examination

Rules 20, 20 bis, Rule 25(1) CR

The following applications for changes relating to an international registration can be presented to OHIM as an 'office of the contracting party of the holder':

- WIPO form MM5: change of ownership, either total or partial, submitted by the IR holder on record (in CTM terminology, this corresponds to a transfer);
- WIPO form MM6: limitation of the list of goods and services for all or some contracting parties;
- WIPO form MM7: renunciation of one or more contracting parties (not all);
- WIPO form MM8: full or partial cancellation of the international registration;
- WIPO form MM9: change of the name or address of the holder;
- WIPO forms MM13/MM14: new licence or amendment to a licence submitted by the IR holder on record;
- WIPO form MM15: for cancelling the recording of a license
- WIPO form MM19: restriction of the holder's right of disposal submitted by the IR holder on record (in CTM terminology, this corresponds to a right *in rem*, levy of execution, enforcement measure or insolvency proceedings contemplated in Articles 19, 20 and 21 CTMR).

Such applications made to OHIM by the IR holder will simply be forwarded to WIPO without further examination. The provisions under the CTMR and CTMIR for the corresponding proceedings do not apply. In particular, the language rules applicable are those under the CR, and there is no OHIM fee to be paid.

These applications can only be filed through OHIM if it is the office of origin or if it acquires competence in respect of the holder as the result of a transfer of the international registration (see Rule 1(xxvi bis) CR). However, this condition will not be examined by OHIM because the latter will simply forward the request, which could have been filed with WIPO directly.

No use will be made of the options provided in Rule 20(1)(a) CR that allow an office of the contracting party of the holder to notify the International Bureau of a restriction of the holder's right of disposal on its own motion.

2.4.2 Cases where applications for changes will be forwarded after examination

Rule 20(1)(a), Rule 20 bis(1), Rule 25(1)(b) CR
Rule 120 CTMIR

The Common Regulations provide that applications for recording a change of ownership, a licence or a restriction of the holder's right of disposal may only be filed directly with WIPO by the holder of the international registration. It would be practically impossible to record a change of ownership or licence with WIPO where:

- the original holder no longer exists (merger, death), or
- the holder is either not cooperating with its licensee or (even more likely) is the beneficiary of an enforcement measure.

For these reasons, the new holder, licensee or beneficiary of the right of disposal has no choice but to file their application with the office of the contracting party of the holder. WIPO will register such applications without any substantive examination on the basis that they have been transmitted by that office.

To avoid a third person becoming the owner or licensee of an international registration, it is imperative that OHIM examines all applications presented by any person other than the holder of the IR in order to verify that there is proof of the transfer, licence or other right, as provided in Rule 120 CTMIR. OHIM limits itself to examining proof of the transfer, licence or other right, and Rule 31(1), (5) CTMIR and the corresponding parts of the OHIM Guidelines on transfers, licences, rights *in rem*, levy of execution and insolvency proceedings apply by analogy. If no proof is furnished, OHIM will refuse to forward the application to WIPO.

This decision is open to appeal.

In all other respects, the rules under the CTMR and CTMIR do not apply. In particular, the application must be in one of the WIPO languages and on the appropriate WIPO form, and no fee is payable to OHIM.

3 OHIM as Designated Office

3.1 Overview

Since 01/10/2004, any person who is a national of, or has a domicile or commercial establishment in, a State which is party to the Madrid Protocol and who is the owner of a national application or registration in that same State (a 'basic mark') may, through the national office where the basic mark is applied for or registered (the 'office of origin'), file an international application or a subsequent designation in which they can designate the European Union.

Once it has examined classification and checked certain formalities (including payment of fees), WIPO will publish the IR in the International Gazette, issue the certificate of registration and notify the designated offices of the international registration. OHIM receives the data from WIPO exclusively in electronic form.

International registrations designating the EU are identified by OHIM under their WIPO registration number preceded by a '**W**' and followed by a **0** in the case of a new IR (e.g. **W01** 234 567) and a **1** in the case of a subsequent designation (e.g. **W10** 987 654). Further designations of the EU for the same IR will be identified as **W2**, **W3**, etc. However, when searching in OHIM databases online the 'W' should not be indicated.

OHIM has 18 months to inform WIPO of all possible grounds for refusal of the EU designation. The 18-month period starts on the day on which OHIM is notified of the designation.

Where corrections are received from WIPO that affect the mark itself, the goods and services or the designation date, it is up to OHIM to decide if a new 18-month period is to start running from the new notification date. Where a correction affects only part of the goods and services, the new time limit applies only to that part and OHIM would have to re-publish the IR in part in the CTM Bulletin and re-open the opposition period only for that part of the goods and services.

The main tasks performed by OHIM as designated office are:

- first republication of IRs designating the EU;
- drawing up of Community search reports;
- examination of formalities, including seniority claims;
- examination on absolute grounds;
- examination of oppositions against IRs;
- processing of communications from WIPO concerning changes to the IRs.

3.2 Professional representation

Article 92(2) Article 93 CTMR

In principle, the IR holder does not need to appoint a representative before OHIM.

Non-EU holders are, however, required to be represented (a) further to a provisional refusal, (b) for filing seniority claims directly before OHIM, or (c) further to an objection on a seniority claim (see the Guidelines, Part A, General Rules, Section 5, Professional Representation and Articles 92 and 93 CTMR).

If the non-EU IR holder has appointed a representative before WIPO who also appears in the database of representatives maintained by OHIM, this representative will automatically be considered to be the representative of the IR holder before OHIM.

Where the non-EU IR holder has not appointed a representative or has appointed a representative before WIPO who does not appear in the database of representatives maintained by OHIM, any notifications of provisional refusal or objection will contain an invitation to appoint a representative in compliance with Articles 92 and 93 CTMR. For the particularities of representation in each of the proceedings before OHIM, see paragraphs 3.3.3, 3.4 and 3.6.6 below.

3.3 First republication, searches and formalities

3.3.1 First republication¹

Article 152 CTMR

Upon receipt, IRs will immediately be republished in Part M.1 of the CTM Bulletin, except where the second language is missing.

Publication will be limited to bibliographic data, the reproduction of the mark and the class numbers, and will not include the actual list of goods and services. This means, in particular, that OHIM will not translate international registrations or the list of goods and services. The publication will also indicate the first and second languages of the IR and contain a reference to the publication of the IR in the WIPO Gazette, which should be consulted for further information. For more details, reference is made to the CTM Bulletin on OHIM's website.

¹ IRs are published first in the International Gazette and then 'republished' by OHIM.

The international registration has, from the date of first republication, the same effect as a published CTM application.

3.3.2 Searches

Article 155 CTMR

As with direct CTM filings, OHIM will draw up a Community search report for each IR, which will cite similar CTMs and IRs designating the EU. The owners of the earlier marks cited in the report will receive a surveillance letter in accordance with Article 155(4) CTMR. In addition, upon request by the international holder, OHIM will send the IR to the participating national offices to have national searches carried out (see the Guidelines Part B, Examination, Section 1, Proceedings).

The national search request must be filed directly with OHIM. Holders of IRs designating the EU must request the national searches and pay the corresponding fee within a period of one month from when WIPO informs OHIM of the designation. Late or missing payments of search fees will be dealt with as if the request for national searches had not been filed and then only the Community search report will be drawn up.

Payment can be made using any of the means of payment accepted by OHIM (for details, see the Guidelines, Part A, General Rules, Section 3, Payment of Fees, Costs and Charges, paragraph 2).

The search reports will be sent directly to the IR holder or, if the latter has appointed a representative before WIPO, to that representative, irrespective of location. The holder will not be required to appoint a representative before OHIM for the sole purpose of receiving the search report or requesting national searches.

3.3.3 Formalities examination

The formalities examination carried out by OHIM on IRs is limited to whether a second language has been indicated, whether the application is for a collective mark, whether there are any seniority claims and whether the list of goods and/or services meets the requirements of clarity and precision as described in Part B.3 Classification.

3.3.3.1 Languages

Article 119(3), (4) CTMR Rule 96(1), Rules 112, 126 CTMIR Rule 9(5)(g)(ii) CR

Rule 9(5)(g)(ii) CR and Rule 126 CTMIR require the applicant for an international application designating the EU to indicate a second language, different from the first one, selected from the four remaining languages of OHIM by ticking the appropriate box in the contracting parties section of WIPO forms MM2/MM3 or MM4.

According to Rule 126 CTMIR, the language of filing of the international application will be the language of the proceedings within the meaning of Article 119(4) CTMR. If the language chosen by the international registration holder in written proceedings is not

the language of the international application, the holder must supply a translation into that language within one month from when the original document was submitted. If the translation is not received within this time limit, the original document is deemed not to have been received by OHIM.

The second language indicated in the international application will be the second language within the meaning of Article 119(3) CTMR, that is, a possible language of proceedings for opposition, revocation or invalidity proceedings before OHIM.

Where no second language has been indicated, the examiner will issue a provisional refusal of protection and give the holder two months from the day on which OHIM issues the provisional refusal pursuant to Rule 112 CTMIR to remedy the deficiency. Where the IR holder is required to be represented in proceedings before OHIM and its representative before WIPO does not appear in the database of representatives maintained by OHIM, the notification of provisional refusal will invite the holder to appoint a representative in compliance with Article 92 and 93 CTMR. This notification will be recorded in the international register, published in the Gazette and sent to the IR holder. The reply to the provisional refusal must be addressed to OHIM.

If the IR holder remedies the deficiency and complies with the requirement to appoint a representative before OHIM, if applicable, within the prescribed time limit, the IR will proceed to republication.

If the deficiency has not been remedied and/or a representative has not been appointed (if applicable), OHIM will confirm the refusal to the IR holder. The holder has two months within which to lodge an appeal. Once the decision is final, OHIM will inform WIPO that the provisional refusal is confirmed.

3.3.3.2 Collective marks

Articles 66, 67 CTMR Rule 43, Rule 121(1), (2), (3) CTMIR
--

In the CTM system, there are only two kinds of mark: individual marks and collective marks (for more details see the Guidelines, Part B, Examination, Section 2, Formalities).

The international application form contains one single indication grouping collective marks, certification marks and guarantee marks. Therefore, if the IR designating the EU is based on a national certification mark, guarantee mark or collective mark, it will be identified as a collective mark before OHIM; this entails the payment of higher fees.

The conditions applying to Community collective marks will also apply to IRs designating the EU as a collective mark.

According to Rule 121(2) CTMIR, the holder must submit the regulations governing use of the mark directly to OHIM within two months of the date on which the International Bureau notified OHIM of the designation.

If, by then, the regulations on use have not been submitted or contain irregularities, or the holder does not comply with the requirements of Article 66, the examiner will issue a provisional refusal of protection and give the holder two months from the day on which OHIM issues the provisional refusal pursuant to Rule 121(3) CTMIR to remedy

the deficiency. Where the IR holder is required to be represented in proceedings before OHIM and its representative before WIPO does not appear in the database of representatives maintained by OHIM, the notification of provisional refusal will invite the holder to appoint a representative in compliance with Article 92 and 93 CTMR. This notification will be recorded in the international register, published in the Gazette and sent to the IR holder. The reply to the provisional refusal must be addressed to OHIM.

If the IR holder remedies the deficiency and complies with the requirement to appoint a representative before OHIM, if applicable, within the prescribed time limit, the international registration will proceed.

If the deficiency has not been remedied and/or a representative has not been appointed (if applicable), OHIM will confirm the refusal to the IR holder, and grant a two-month time limit for lodging an appeal. Once the decision is final, OHIM will inform WIPO that the provisional refusal is confirmed.

When, in the answer to the provisional refusal, elements are submitted satisfying OHIM that the basic mark is a certification mark or guarantee mark and the IR holder is not qualified to be the owner of a Community collective mark, OHIM will examine the designation as an individual mark. The IR holder will be informed accordingly and will also be reimbursed with the difference in euros between the fees for an individual designation of the EU and for a collective one.

3.3.3.3 Seniority claims

Seniority claims filed together with the designation

Article 153(1) CTMR Rule 9(3)(d), Rule 9(7), Rule 108, Rule 109(1), (2), (3), (4) CTMIR Rule 9(5)(g)(i), Rule 21 bis CR

The applicant may, when designating the EU in an international application or a subsequent designation, claim the seniority of an earlier mark registered in a Member State. Such a claim must be presented by attaching form MM17 to the international application or subsequent designation request, which should include for each claim:

- the EU Member State in which the earlier right is registered;
- the registration number;
- the filing date of the relevant registration.

There is no equivalent provision to Rule 8(2) CTMIR applicable to direct CTM filings.

No certificates or documents in support of the seniority claims must be attached to the MM17 form, as they will not be transmitted to OHIM by WIPO.

Seniority claims presented together with the international application or subsequent designation will be examined in the same way as seniority claims presented with a Community trade mark application. For more information, please refer to the Guidelines, Part B, Examination, Section 2, Formalities.

If it is necessary to file documentation in support of the seniority claim or if the claim contains irregularities, the examiner will issue a deficiency letter giving the IR holder two months within which to remedy the deficiency. Where the IR holder is required to be represented in proceedings before the OHIM and its representative before WIPO

does not appear in the database of representatives maintained by OHIM, the holder will also be invited to appoint a representative before OHIM.

If the seniority claim is accepted by OHIM, the IP offices concerned will be informed. WIPO need not be informed since no change in the international register is required.

If the deficiency has not been remedied and/or a representative has not been appointed (if applicable), the right of seniority will be lost pursuant to Rule 109(2) CTMIR. The IR holder may request a decision, which can be appealed. Once it is final, OHIM will inform WIPO of any loss, refusal or cancellation of the seniority right or of any withdrawal of the seniority claim. Those changes will be recorded in the international register and published by WIPO.

Seniority claims filed directly before OHIM

Article 153(2) CTMR Rule 110(1), (2), (4), (5), (6) CTMIR Rule 21 bis (2) CR
--

The IR holder may also claim the seniority of an earlier mark registered in a Member State directly before OHIM upon publication of the final acceptance of the IR. Where the IR holder is required to be represented in proceedings before OHIM and its representative before WIPO does not appear in the database of representatives maintained by OHIM, OHIM will invite the holder to appoint a representative in compliance with Article 92 and 93 CTMR.

The reply to the deficiency letter must be addressed to OHIM.

Any seniority claim presented in the interval between the filing of the international application and the publication of the final acceptance of the IR will be deemed to have been received by OHIM on the date of publication of the final acceptance of the IR and will therefore be examined by OHIM after that date.

If it is necessary to file documentation in support of the seniority claim or if the claim contains irregularities, the examiner will issue a deficiency letter giving the IR holder two months within which to remedy the deficiency. Where the holder of the international registration is required to be represented in proceedings before OHIM and its representative before WIPO does not appear in the database of representatives maintained by OHIM, the holder will also be requested to appoint a representative before OHIM.

If the seniority claim is accepted by OHIM, it will inform WIPO, which will record this fact in the international register and publish it.

The IP offices concerned will be informed pursuant to Rule 110(6) CTMIR.

If the deficiency is not remedied and/or a representative has not been appointed (if applicable), the seniority right will be refused and the IR holder will be given two months within which to lodge an appeal. In such cases, WIPO is not informed. The same applies if the seniority claim is abandoned.

3.3.3.4 Vague terms

Article 36 and Article 145 CTMR Rule 2 and Rule 9 CTMIR
--

International registrations designating the EU must be examined for the specification of broad or vague terms in the list of goods and services in the same way as direct CTMAs (for details please consult the Guidelines, Part B, Examination, Section 3, Classification).

Where the IR contains vague terms in the list of goods and/or services that lack clarity or precision, the Office will issue a provisional refusal of protection and give the holder two months from the day on which OHIM issues the provisional refusal pursuant to Rule 2 and Rule 9 CTMIR to remedy the deficiency. Where the IR holder is required to be represented in proceedings before OHIM and its representative before WIPO does not appear in the database of representatives maintained by OHIM, the notification of provisional refusal will invite the holder to appoint a representative in compliance with Article 92 and Article 93 CTMR. This notification will be recorded in the international register, published in the Gazette and sent to the IR holder. The reply to the provisional refusal must be addressed to OHIM.

Once the provisional refusal has been sent, further examination is the same as for a direct CTMA; there will be direct exchanges with the holder or its representative as often as is required. The terms that need to be clarified by the IR holder should always be in the same class as the original wording in the International Register.

If, after re-examining the case, the objection is waived or the IR holder remedies the deficiency and complies with the requirement to appoint a representative before OHIM, if applicable, within the prescribed time limit, the Office will issue an interim status of the mark to WIPO, provided that no other provisional refusal is pending and that the opposition period is still running; the IR will then proceed.

Replies received by the IR holder or its representative will not be addressed where both are located outside the EU.

If the holder fails to overcome the objections or convince the examiner that they are unfounded, or fails to respond to the objection, the provisional refusal will be confirmed. In other words, if the provisional refusal concerned only some of the goods and services, only those goods and services will be refused but the remaining goods and services will be accepted. The IR holder will be given two months within which to lodge an appeal.

Once the decision is final and provided that there is a total refusal, OHIM will inform WIPO that the provisional refusal is confirmed. If the refusal is only partial, the communication to WIPO will be issued once all the other procedures (absolute grounds/oppositions) have been completed or the opposition period is over without any opposition being received (see paragraph 3.9 below).

3.4 Absolute grounds for refusal

Article 154(1) CTMR, Rule 18 bis (1) CR Rule 112 (1),(5), , 113 CTMIR
--

International registrations designating the EU shall be subject to examination as to absolute grounds for refusal in the same way as direct CTMAs (for details, please consult the Guidelines, Part B, Examination, Section 4, Absolute Grounds for Refusal and Community Collective Marks).

If OHIM finds that the mark is eligible for protection, and provided that no other provisional refusal is pending, it will send an interim status of the mark to WIPO, indicating that the *ex-officio* examination has been completed, but that the IR is still open to oppositions or third-party observations. This notification will be recorded in the international register, published in the Gazette and communicated to the IR holder.

If OHIM finds that the mark is not eligible for protection, it will send a provisional refusal of protection, giving the holder two months from the day on which the provisional refusal is sent to file observations. Where the holder of the international registration is obliged to be represented in proceedings before OHIM and its representative before WIPO does not appear in the database of representatives maintained by OHIM, the notification of provisional refusal will also invite the holder to appoint a representative in compliance with Articles 92 and 93 C TMR. This notification will be recorded in the international register, published in the Gazette and communicated to the IR holder. The reply to the provisional refusal must be addressed to OHIM.

If, after re-examining the case, the objection is waived, the examiner will issue an interim status of the mark to WIPO, provided that no other provisional refusal is pending and the opposition period is still running.

Where no provisional refusal has been issued by OHIM before the start of the opposition period (six months after republication), the *ex Officio* examination shall be considered concluded. An interim status of the mark will therefore be issued automatically.

Once the provisional refusal has been sent, further examination is the same as for a direct CTMA; direct exchanges with the holder or its representative will be held as often as required.

Replies received by the IR holder or its representative will not be addressed where both are located outside the EU.

If the holder fails to overcome the objections or convince the examiner that they are unfounded, or fails to respond to the objection, the refusal will be confirmed. In other words, if the provisional refusal concerned only some of the goods and services, only those goods and services will be refused but the remaining goods and services will be accepted. The IR holder will be given two months within which to lodge an appeal.

Once the decision is final and provided that there is a total refusal, OHIM will inform WIPO that the provisional refusal is confirmed. If the absolute grounds refusal is only partial, the communication to WIPO will be issued once all other procedures (specification of goods and services/oppositions) are terminated or the opposition period is over with no opposition received (see point 3.9 below).

3.5 Third-party observations

Article 40 CTMR
Rule 112(5) CTMIR

Third-party observations can be validly filed at OHIM from the date of notification of the IR to OHIM until at least the end of the opposition period and, if an opposition was filed, as long as the opposition is pending, but not beyond the 18-month period OHIM has for informing WIPO of all possible grounds for refusal (see paragraph 3.1 above).

If third-party observations are received before OHIM communicates the outcome of the absolute grounds examination to WIPO and OHIM considers the observations justified, a provisional refusal will be issued without mentioning the third-party observations.

If third-party observations are received after a provisional refusal on absolute grounds has been issued in relation to goods and services other than those to which the observations relate and the OHIM considers the observations justified, a further provisional refusal will be issued without mentioning the third-party observations.

If third-party observations are received after an interim status of the mark has been issued and the OHIM considers them justified, a provisional refusal further to third-party observations will be issued. The observations will be attached to the provisional refusal.

The further examination procedure is identical to the procedure described in the Guidelines, Part B, Examination, Section 1, Proceedings, paragraph 3.1, Procedural aspects concerning observations by third parties and review of absolute grounds.

If OHIM considers the observations unjustified, they will simply be forwarded to the applicant without WIPO being informed.

3.6 Opposition

Article 156 CTMR
Rules 114 and 115 CTMIR

3.6.1 Timing

Oppositions may be filed against the international registration between the sixth month and the ninth month following the date of first republication. For example, if the first republication is on 15/02/2012, the opposition period starts on 16/08/2012 and ends on 15/11/2012.

The opposition period is fixed and is independent of the outcome of the procedure on absolute grounds. Nevertheless, the start of the opposition procedure depends on the outcome of the absolute grounds examination insofar as the opposition procedure may be suspended if an absolute grounds refusal is issued.

Oppositions filed after the republication of the IR but prior to the start of the opposition period will be kept on hold and be deemed to have been filed on the first day of the

opposition period. If the opposition is withdrawn before that date, the opposition fee is refunded.

For full details on the opposition procedure, please consult the Guidelines, Part C, Opposition, Section 1, Procedural Matters.

3.6.2 Receipt and informing the international holder

Rule 16a, Rule 114(3) CTMIR

OHIM will issue a receipt to the opponent. If the opposition has been received before the beginning of the opposition period, a letter will be sent to the opponent, informing it that the opposition will be deemed to have been received on the first day of the opposition period and that the opposition will be put on hold until then.

OHIM will also send a copy of the notice of opposition to the IR holder or, if the latter has appointed a representative before WIPO and OHIM holds sufficient contact information, to that representative, irrespective of location, for information purposes.

3.6.3 Fees

Article 156(2) CTMR
Rule 54 CTMIR

The opposition shall not be treated as duly entered until the opposition fee has been paid. If payment of the fee within the opposition period cannot be established, the opposition will be deemed not to have been entered.

If the opponent disagrees with this finding, it has the right to request a formal decision on loss of rights. If OHIM decides to confirm the finding, both parties will be informed thereof. If the opponent appeals this decision, OHIM will issue a provisional refusal to WIPO, even if incomplete, for the sole purpose of meeting the 18-month time limit. If the decision becomes final, the provisional refusal will be reversed. Otherwise, the opposition procedure will start in the normal manner.

3.6.4 Admissibility check

Article 92(2) CTMR
Rules 17, 115 CTMIR

OHIM will examine whether the opposition is admissible and whether it contains the particulars required by WIPO.

If the opposition is considered inadmissible, OHIM will inform the IR holder accordingly and no provisional refusal based on an opposition will be sent to WIPO.

For full details on opposition proceedings see the Guidelines, Part C, Opposition, Section 1, Procedural Matters.

3.6.5 Language of proceedings

Article 119(6) CTMR
Rule 16(1) CTMIR

Oppositions (like cancellation requests) must be filed in the language of the international registration (the first language) or in the second language that the international holder is obliged to indicate when designating the EU. The opponent may choose one of these two languages as the language of the opposition proceedings. The opposition may also be filed in any of the other three OHIM languages provided that a translation into the language of the proceedings is filed within one month.

OHIM will use:

- the language of the opposition proceedings chosen by the opponent in all communications made directly to the parties;
- the language in which the IR was registered by WIPO (first language) in all communications with WIPO, e.g. the provisional refusal.

3.6.6 Representation of the IR holder

3.6.6.1 Opposition receipts

Rule 16a CTMIR

If applicable, in the opposition receipts OHIM will inform the IR holder that if it does not appoint a representative who complies with the requirements stipulated in Articles 92(3) or 93 CTMR within one month of receipt of the communication, OHIM will communicate the formal requirement to appoint a representative to the IR holder together with the opposition deadlines once the opposition is found admissible.

Where the IR holder has a WIPO representative *within* the EU who does not appear in the database of representatives maintained by OHIM, OHIM will inform this representative that if they wish to represent the IR holder before OHIM they must specify the basis of their entitlement (i.e. whether they are a legal practitioner or professional representative within the meaning of Article 93(1)(a) or (b) CTMR or an employee representative within the meaning of Article 92(3) CTMR) (see also the Guidelines, Part A, General Rules, Section 5, Professional Representation).

3.6.6.2 Notification of commencement of opposition proceedings

Rule 18(1) CTMIR

If the opposition has been found admissible and where, despite the invitation pursuant to paragraph 3.6.6.1 above, the IR holder fails to appoint an EU representative before the opposition has been notified as admissible, further processing of the file will depend on whether or not the *IR holder* is required to be represented before OHIM pursuant to Article 92(2) CTMR.

- If the IR holder is *not* required to be represented before OHIM, the proceedings will continue directly with the IR holder, i.e. the IR holder will be sent notification of the admissibility of the opposition and the time limits set for substantiation.
- If the IR holder *is* required to be represented before OHIM, the IR holder will be notified of the admissibility of the opposition and will be formally requested to appoint an EU representative within two months of receipt of the communication (Rule 114(4) CTMIR), failing which the IR will be refused with a right to appeal. Once the decision is final the opposition proceedings will be closed and WIPO will be informed. For the attribution of costs, the normal rules apply. This means that no decision on the costs will be taken and the opposition fee will not be refunded.

3.6.7 Provisional refusal (based on relative grounds)

Article 156(2) CTMR
Rule 18, Rule 115(1) CTMIR
Article 5(1), Article 5(2)(a), (b) MP
Rule 17(1)(a), (2)(v) CR

Any opposition that is deemed to have been entered and is admissible will lead to a notification of provisional refusal being sent to WIPO based on the pending opposition. WIPO will be informed of every admissible opposition duly entered within the opposition period by means of a separate provisional refusal for each opposition.

The provisional refusal may be partial or total. It will contain the earlier rights invoked, the relevant list of goods and services on which the opposition is based and, in the case of a partial refusal, the list of goods and services against which the opposition is directed.

The opponent must provide the list of goods and services on which the opposition is based in the language of the opposition proceedings. OHIM will send this list to WIPO in that language and will not translate it into the language in which the international registration was registered.

This notification will be recorded in the international register, published in the Gazette and communicated to the IR holder. It will not, however, contain any time limit, as the time limit for commencement of the proceedings will be set in the direct notification to the parties made in parallel by OHIM, as in the case of a normal CTM.

3.6.8 Suspension of opposition where there is a pending provisional refusal on the specification of goods and services and/or absolute grounds

Rule 18(2), 20 (7) CTMIR

If the opposition was filed after OHIM had already sent a notification of provisional refusal on the specification of goods and services (see paragraph 3.3.3.4 above) and/or absolute grounds (see paragraph 3.4 above) in relation to the same goods and services, OHIM will inform WIPO of the provisional refusal and communicate to the parties that, as from the date of the communication, the opposition procedure is

suspended until a final decision on the specification of goods and services and/or absolute grounds is issued.

If the provisional refusal on the specification of goods and services and/or absolute grounds leads to a final refusal of protection for all goods and services or for those contested by the opposition, the opposition procedure is closed without proceeding to a decision and the opposition fee is refunded.

If the refusal on the specification of goods and services and/or absolute grounds is not maintained or is only partially maintained, the opposition procedure is resumed for the remaining goods and services.

3.7 Cancellation of the IR or renunciation of the EU designation

If, further to a provisional refusal on the specification of goods and services and/or absolute or relative grounds, the holder requests the cancellation of the IR from the international register or renounces its designation of the EU, the file is closed upon receipt of the notification by WIPO. If this happens before the start of the adversarial part of the opposition proceedings, the opposition fee is reimbursed to the opponent, since it is equivalent to withdrawal of the CTMA. The IR holder must submit such requests to WIPO (or through the office of origin) using the official form (MM7/MM8). OHIM cannot act as an intermediary and will not forward these requests to WIPO.

However, cancellation of the IR at the request of the office of origin (due to a ‘central attack’ during the five-year dependency period) is considered equivalent to rejection of the CTMA in parallel proceedings under Rule 18(2) CTMIR, in which case the opposition fee is not reimbursed.

3.8 Limitations of the list of goods and services

Article 9 bis iii MP, Rule 25 CR

OHIM cannot communicate limitations as such to WIPO.

Therefore, further to a provisional refusal on the specification of goods and services and/or absolute or relative grounds, the IR holder can choose to limit the list of goods or services:

- either through WIPO, using the appropriate form (MM6/MM8) (in which case, provided the limitation allows the objection to be waived, OHIM will communicate to WIPO that the provisional refusal is withdrawn), or
- directly with OHIM. In this case OHIM will simply confirm the provisional refusal. In other words, WIPO’s register will reflect the partial refusal, not the limitation as such.

Where there is no provisional refusal pending, all limitations must be filed only through WIPO. WIPO will record the limitation and forward it to OHIM for examination.

Limitations will be examined in the same way as limitations or partial surrenders of a CTM(A) (see the Guidelines, Part B, Examination, Section 3, Classification, and the Guidelines, Part E, Register Operations, Section 1, Changes in a Registration). When the limitation has been submitted through WIPO and is considered unacceptable by

OHIM, a declaration that the limitation has no effect in the territory of the EU will be issued pursuant to Rule 27(5) CR. This declaration will not be subject to review or appeal.

Partial cancellations at the request of the office of origin (further to a 'central attack' during the five-year dependency period) will be recorded as they are by OHIM.

If the limitation is submitted before the start of the adversarial part of the opposition proceedings and allows the opposition proceedings to be terminated, the opposition fee is reimbursed to the opponent.

3.9 Confirmation or withdrawal of provisional refusal and issue of Statement of Grant of Protection

Rules 113(2)(a), 115(5)(a), 116(1) CTMIR, Rule 18ter (1) (2) (3) CR

If one or several notifications of provisional refusal have been sent to WIPO, OHIM must, once all procedures have been completed and all decisions are final,

- either confirm the provisional refusal(s) to WIPO
- or send a Statement of Grant of Protection to WIPO indicating that the provisional refusal(s) is/are partially or totally withdrawn. The Statement of Grant of Protection must specify for which goods and services the mark is accepted.

If, upon expiry of the opposition period, the IR has not been the subject of any provisional refusal, OHIM will send a Statement of Grant of Protection to WIPO for all the goods and services.

The Statement of Grant of Protection must include the date on which the IR was republished in Part M.3 of the CTM Bulletin.

OHIM will not issue any registration certificate for IRs.

3.10 Second republication

Articles 151(2),(3), 152(2), Article 160 CTMR
Rule 116(2) CTMIR

The second republication by OHIM will take place when, upon conclusion of all procedures, the IR is (at least in part) protected in the EU.

The date of the second republication will be the starting point for the five-year use period and the date from which the registration may be invoked against an infringer.

From the date of second republication, the international application has the same effects as a registered CTM. These effects may therefore come into force before the 18-month time limit has elapsed.

Only the following data will be published in Part M.3.1 of the CTM Bulletin:

- 111 Number of the international registration;
- 460 Date of publication in the International Gazette (if applicable);
- 400 Date(s), number(s) and page(s) of previous publication(s) in the CTM Bulletin;
- 450 Date of publication of the international registration or subsequent designation in the CTM Bulletin.

3.11 Transfer of the designation of the EU

Rule 120 CTMIR

The IR represents a single registration for administrative purposes since it is one entry in the international register. However, in practice, it is a bundle of national (regional) marks with regard to substantive effects and the trade mark as an object of property. As regards the link with the basic mark, while the IR must originally be in the name of the proprietor of the basic mark, it may thereafter be transferred independently of the basic mark.

In fact, a 'transfer of the international registration' is nothing more than a transfer of the mark with effect for one, several or all designated Contracting Parties. In other words, it is equivalent to a transfer of the corresponding number of national (regional) marks.

Transfers may not be presented directly to OHIM in its capacity as designated office; they must be submitted to WIPO or through the office of the contracting party of the holder using the WIPO MM5 form. Once recorded by WIPO, the change of ownership of the designation of the EU will be notified to OHIM and automatically integrated into the OHIM database.

In its capacity as designated office, OHIM has nothing to examine for the transfer. Rule 27(4) CR allows a designated office to declare to WIPO that, as far as its designation is concerned, a change of ownership has no effect. However, OHIM does not apply this provision since it does not have the authority to re-examine whether the change in the international register was based on proof of the transfer. Furthermore, OHIM does not re-examine the mark for potential deceptiveness either (Article 17(4) CTMR) unless the transfer is filed during the absolute grounds examination phase.

3.12 Invalidity, revocation and counterclaims

Articles 51, 52, 53, Articles 151(2), 152(2), Articles 158, 160 CTMR Rule 117 CTMIR
--

The effects of an IR designating the EU may be declared invalid; the application for invalidation of the effects of an IR designating the EU corresponds, in CTM terminology, to an application for declaration of revocation or for invalidity.

There is no time limit for filing an application for invalidity/revocation with the following exceptions:

- an application for invalidity of an IR designating the EU is only admissible once the designation has been finally accepted by OHIM, namely once the Statement of Grant of Protection has been sent.
- an application for revocation on the basis of non-use of an IR designating the EU is only admissible if, at the date of filing the request, the final acceptance of the IR had been republished by OHIM at least five years earlier (see Article 160 CTMR, stating that the date of publication pursuant to Article 152(2) takes the place of the date of registration for the purpose of establishing the date as from which the mark that is the subject of an IR designating the EU must be put to genuine use in the European Union).

OHIM will examine the request as if it were directed against a direct CTM (for further information, see the Guidelines, Part D, Cancellation).

If the IR designating the EU is totally or partially invalidated/revoked further to a final decision or a counterclaim action, OHIM will notify WIPO according to Article 5(6) Madrid Protocol and Rule 19 CR. WIPO will record the invalidation/revocation and publish it in the International Gazette.

3.13 Fee management

As a consequence of setting the equivalent of the registration fee at zero for direct CTMs and the application of this change to Madrid fees on 12/08/2009, there will no longer be any reimbursement of part of the individual fee for IRs designating the EU with a designation date later than the above date that are finally refused or for which the IR holder has renounced protection in respect of the EU prior to the refusal decision becoming final pursuant to Articles 154 and 156 CTMR.

Pursuant to Article 3 (last paragraph) of Commission Regulation (EC) No 355/2009 of 31/03/2009 amending Commission Regulation (EC) No 2869/95 of 13/12/1995 on the fees payable to OHIM, designations of the EU filed before 12/08/2009 will continue to benefit from a refund of the registration fee in the event of refusal or withdrawal as per Article 13 CTMFR in the version in force prior to the entry into force of Commission Regulation No 355/2009.

4 Conversion, Transformation, Replacement

4.1 Preliminary remarks

Conversion or transformation

Both apply when an IR designating the EU ceases to have effect, but for different reasons:

- When an IR ceases to have effect because the mark of origin has been the subject of a 'central attack' during the five-year dependency period, **transformation** into a direct CTM application is possible. Transformation is not available when the IR has been cancelled at the holder's request or the holder has renounced in part or in whole the designation of the EU. The EU designation must still be effective when the transformation is requested, that is, it must not

have been finally refused by OHIM; otherwise, there will be nothing left to transform and conversion of the designation would be the only possibility.

- When the IR designating the EU is finally refused by OHIM or ceases to have effect for reasons independent of the basic trade mark, only **conversion** is available. Conversion is possible within the prescribed time limit even if, in the meanwhile, the IR has also been cancelled from the international register at the request of the office of origin, i.e. via a 'central attack'.

4.2 Conversion²

Articles 112 to 114, 159 CTMR
Rule 24(2)(a)(iii) CR

The legal option of conversion has its origins in the CTM System, which has been adapted to allow a designation of the EU through an IR to be converted into a national trade mark application, just like for a direct CTM. The CTM System and Madrid System have also been adapted to allow for conversion into a designation of Member States party to the Madrid System (known as 'opting back'). Malta is not party to the Madrid System.

The latter is forwarded to WIPO as a request for subsequent designation of the Member State(s). This type of subsequent designation is the only one that, instead of being filed with the office of origin or with WIPO directly, has to be filed through the designated office.

For full details on Conversion, see the Guidelines, Part E, Register Operations, Section 2, Conversion.

4.3 Transformation

Article 6(3), Article 9 *quinquies* MP
Article 161 CTMR
Rule 84(2)(p), Rule 124 CTMIR

4.3.1 Preliminary remarks

Transformation has its origins solely in the Madrid Protocol. It was introduced in order to soften the consequences of the five-year dependency period already set in place by the Madrid Agreement. Where an IR is cancelled in whole or in part because the basic mark has ceased to have effect, and the holder files an application for the same mark and same goods and services as the cancelled registration with the office of any contracting party for which the IR had effect, that application will be treated as if it had been filed on the date of the IR or, where the contracting parties had been designated

² In English, 'conversion' is used to describe a specific legal provision of the CTM System (Article 112 *et seq.*) while 'transformation' is used to describe that in Article 9 *quinquies* of the Madrid Protocol. In other languages, only one word is used to describe these two different legal provisions (e.g. in Spanish 'transformación'). In order to avoid confusion, the English word 'conversion' could be used in parentheses when, for example, the Spanish word 'transformación' is used within the meaning of Article 112 CTMR.

subsequently, on the date of the subsequent designation; it shall also enjoy the same priority, if any.

This filing is not governed by the Protocol, nor is WIPO involved in any way. Unlike conversion, transformation of the EU designation into national applications is not possible. Nor is it possible to transform an EU designation into individual Member State designations. If the EU has been designated, the IR has effect in the EU and not in individual Member States as such.

The EU designation must still be effective when the transformation is requested, that is, it must not have been finally refused by OHIM; otherwise, there will be nothing left to transform and conversion of the designation would be the only possibility.

4.3.2 Principle and effects

Article 27 CTMR

Following a **cancellation in whole or in part of an IR designating the EU at the request of the office of origin** under Article 9 *quinquies* of the Protocol (i.e. following a 'central attack' during the five-year dependency period), the holder may file a 'direct' CTM application for the same mark and same goods and services as the cancelled mark.

The application resulting from the transformation will be treated by OHIM as if it had been filed on the date of the original IR or, where the EU was designated subsequently to the IR, on the date of the subsequent designation; it shall also enjoy the same priority, if any.

The date of the IR or of the subsequent designation will not become the filing date of the Community trade mark application. Article 27 CTMR, which applies *mutatis mutandis*, lays down clear conditions for the granting of a filing date, subject also to payment of the application fee within one month. However, the date of the IR or subsequent designation will be the date that determines the 'earlier right effect' of the CTM for the purposes of priority searches, oppositions, etc.

Unlike for priority and seniority claims (Rule 9(8) CTMIR), it is not possible to have a 'split' or 'partial' date, with one date being only for those goods which were contained in the IR and the filing date of the Community trade mark application being the relevant date for the additional goods and services. No such partial transformation effect is foreseen in Article 9 *quinquies* of the Madrid Protocol or Article 161 CTMR.

Renewal starts to run from the filing date of the transformed CTM.

4.3.3 Procedure

The conditions for invoking a transformation right under Article 9 *quinquies* of the Madrid Protocol are:

- that the application is filed within a period of three months from the date on which the IR was cancelled in whole or in part, and

- that the goods and services of the ensuing application are in fact covered by the list of goods and services of the designation of the EU.

The applicant needs to claim this right in the relevant section provided in the CTM e-filing or CTM application form. The following indications must be given in this section:

1. number of the IR that has been cancelled in whole or in part;
2. date on which the IR was cancelled in whole or in part by WIPO;
3. date of the IR pursuant to Article 3(4) MP or date of territorial extension to the EU made subsequently to the IR pursuant to Article 3 *ter* (2) MP;
4. date of priority claimed in the IR, if any.

OHIM will invite the applicant to remedy any deficiencies detected within a period of two months.

If the deficiencies are not remedied, the right to the date of the IR or the territorial extension and, if any, of the priority of the IR will be lost. In other words, should the transformation be finally refused, the CTMA will be examined as a 'normal' application.

4.3.4 Examination

4.3.4.1 Application for transformation of IR designating the EU where no particulars have been published

When the application for transformation relates to an IR designating the EU for which the particulars have not been published pursuant to Article 152(2) CTMR (in other words that has not been finally accepted by OHIM), the CTM resulting from transformation will be treated as a normal CTM application; it will be examined as to classification, formalities and absolute grounds and published for opposition purposes. Nothing in the regulations allows OHIM to omit the examination process.

Nevertheless, since this case presupposes that an IR designating the EU had already existed, OHIM can take advantage of the classification of the list of goods and services of the cancelled IR (as far as it complies with OHIM rules) as well as the Community search reports already issued for that IR (since the date of the ensuing CTM application is the same as the date of the original IR, the search report must by definition come to the same results).

The CTM will be published in Part A of the CTM Bulletin for opposition purposes with an additional field under INID code 646, mentioning the details of the transformation. The remainder of the procedure will be the same as for a normal CTM filing, including if an opposition procedure had already been initiated against the IR designating the EU without reaching the final decision stage. In such a case, the previous opposition procedure would be closed and a new opposition would need to be filed.

4.3.4.2 Application for transformation of IR designating the EU where particulars have been published

When the application for transformation relates to an IR designating the EU for which the particulars have already been published pursuant to Article 152(2) CTMR, the examination and opposition stage are omitted (Article 37 to 42 CTMR).

Nevertheless, the list of goods and services will have to be translated into all languages. The CTM will then be published in Part B.2 of the CTM Bulletin with the translations and the additional INID code 646, and the registration certificate will be issued immediately.

4.3.5 Transformation and Seniority

If seniority claims have been accepted by OHIM and are registered by WIPO in the file for the transformed IR designating the EU, there is no need to claim seniority again in the CTM resulting from transformation. This is not explicitly foreseen in Rule 124(2) CTMIR (only priority is mentioned under (d)) but is extended by analogy to seniority in view of the fact that:

- OHIM has already accepted the claims and WIPO has published them,
- where the owner had let the earlier marks lapse in the meanwhile, it would not be able to file new claims before OHIM (one condition of a valid seniority claim being that the earlier right is both registered and in force when the claim is made).

4.3.6 Fees

There is no specific ‘transformation’ fee. The CTM application resulting from the transformation of the IR designating the EU is subject to the same fees as a ‘normal’ CTM application, namely the basic fee.

The basic fee for the CTM application must be paid to OHIM within one month of the filing of the CTM requesting transformation in order for the request to comply with Article 27 CTMR and Article 9 *quinquies* (iii) and the transformation to be accepted. For example, if the end of the three-month time limit for transformation is 01/04/2012 and transformation into a CTMA is filed on 30/3/2012, the deadline for payment of the basic fee is 30/04/2012. If payment occurs after that date, the conditions for transformation are not met, transformation will be refused and the filing date given to the CTMA will be the date of the payment.

4.4 Replacement

Article 157 CTMR Rule 84(2) CTMIR Article 4 bis MP Rule 21 CR
--

4.4.1 Preliminary remarks

Replacement has its origins in the Madrid Agreement and Madrid Protocol. A mark that is registered with the office of a contracting party is, under certain conditions, deemed to be replaced by an international registration of the same mark without prejudice to the rights already acquired (earlier date). The wording of Article 4 bis (1) MP clearly provides that replacement is deemed to take place automatically, without the need for any action by the holder and without any record having to be made of the replacement. Nevertheless, it is possible to ask OHIM to take note of the replacement in its Register

(Rule 21 CR). The purpose of this procedure is to ensure that the relevant information concerning the replacement is made available to third parties in the national or regional registers as well as in the international register. In other words, it is not an obligation to have the replacement registered in order to be able to invoke it, but it can be useful.

Apart from the qualification relating to earlier acquired rights, neither the Agreement nor the Protocol elaborates further on replacement.

4.4.2 Principle and effects

In accordance with Article 4 bis of the Agreement and the Protocol, the holder **may** request OHIM to take note in its Register that **a CTM registration is replaced by a corresponding IR. The holder's rights in the EU should be deemed to start from the date of the earlier CTM registration.** A reference will therefore be introduced in the CTM Register that a direct CTM has been replaced by a designation of the EU through an IR and published.

4.4.3 Procedure

A request for replacement may be filed at OHIM by the international holder at any time after notification of the EU designation by WIPO.

Once a request to record a replacement has been received, OHIM will carry out a formal examination, checking that the marks are identical, that all the goods and services listed in the CTM are listed in the IR designating the EU, that the parties are identical and that the CTM has been registered prior to the designation of the EU. The IR need not have an identical list of goods and services: the list may be broader in scope. It cannot, however, be narrower. If the list is narrower a deficiency will be issued. This deficiency may normally be overcome by partially surrendering the goods and services of the CTM falling outside the scope of the IR.

OHIM considers it sufficient for noting the replacement in the Register if the IR and CTM coexist on the date of the IR. In particular, should the designation of the EU through an IR not yet be finally accepted, OHIM will not wait for final acceptance before recording the replacement. It is up to the international holder to decide when to request the replacement.

If all conditions are met, OHIM will note the replacement in the CTM Register and inform WIPO that a CTM has been replaced by an IR as per Rule 21 CR, indicating:

- the number of the IR
- the CTM number
- the CTM application date
- the CTM registration date
- the priority date(s) (if relevant)
- the seniority number(s), filing date(s) and country/countries (if relevant)
- the list of goods and services of the replacement (if relevant).

After the replacement has been recorded, the CTM is maintained normally in the Register as long as the holder renews it. In other words, there is coexistence between the replaced CTM in force and the IR designating the EU.

According to Rule 21(2) of the Common Regulations under the Madrid Agreement and Protocol, WIPO will record the indications notified under paragraph (1) of that rule in the international register, publish them and inform the holder accordingly, in order to ensure that the relevant information concerning replacement is made available to third parties. Nevertheless, there is no obligation for OHIM to communicate further changes affecting the replaced CTM.

4.4.4 Fees

The request for taking note of a replacement is free of charge.

4.4.5 Publication

Rule 84(2), Rule 85 CTMIR

The replacement is entered in the CTM Register and published in the CTM Bulletin under Part C.3.7.

4.4.6 Replacement and seniority

Article 4 bis(1)MP

Since replacement occurs 'without prejudice to any rights acquired' by virtue of the earlier registration, OHIM will include information on the seniority claims contained in the replaced CTM registration within the content of the notification to be sent to WIPO under Rule 21 CR.

4.4.7 Replacement and transformation

If the IR that replaced the direct CTM ceases to have effect following a 'central attack', and provided that the conditions laid down by Article 9 *quinquies* of the Protocol are met, the holder can request a transformation of the IR under Article 9 *quinquies* while maintaining the effects of the replacement of the CTM and its earlier date effects, including priority or seniority if applicable.

4.4.8 Replacement and conversion

The IR and the CTM should coexist on the date of the IR if the replacement is to be effective. Therefore, if the IR that replaces the direct CTM is finally refused by OHIM (e.g. further to an opposition), the holder can request conversion of the designation of the EU and should be able to maintain the effects of the replacement of the CTM and its earlier date effects, including priority or seniority if applicable.

***GUIDELINES FOR EXAMINATION IN THE
OFFICE FOR HARMONIZATION IN THE
INTERNAL MARKET (TRADE MARKS AND
DESIGNS) ON REGISTERED COMMUNITY
DESIGNS***

***EXAMINATION OF APPLICATIONS FOR
REGISTERED COMMUNITY DESIGNS***

Table of Contents

1	Introduction.....	7
1.1	Purpose of the Guidelines	7
1.2	General principles	7
1.2.1	Duty to state reasons.....	7
1.2.2	Right to be heard	8
1.2.3	Compliance with time limits	8
1.2.4	Scope of the examination carried out by the Office.....	9
1.2.5	User-friendliness.....	9
2	Filing an Application at OHIM.....	9
2.1	Introduction	9
2.2	Form of the application.....	10
2.2.1	Different means of filing	10
2.2.2	Use of the official form.....	10
2.2.3	Applications sent by post or personal delivery	10
2.2.4	E-filing.....	11
2.2.5	Fax.....	11
2.3	Content of the application	11
2.4	Language of the application	11
2.5	Representation of the applicant	12
2.5.1	When is representation mandatory?	12
2.5.2	Who may represent?	12
2.6	Date of receipt, file number and issue of receipt	13
2.6.1	Applications filed through national offices (Intellectual Property Office of a Member State or Benelux Office for Intellectual Property (BOIP)).....	13
2.6.2	Applications received directly at the Office.....	13
2.7	Registration or examination report	13
2.7.1	Registration.....	13
2.7.2	Examination report and informal communication on possible deficiencies ('preliminary examination report')	14
2.7.2.1	Priority claims and supporting documents.....	14
2.7.2.2	Priority claims made subsequent to the filing	15
2.7.2.3	Application filed by fax.....	15
2.7.2.4	Payment of fees	15
2.7.2.5	Multiple applications and request for partial deferment	16
3	Allocation of a Filing Date.....	16
3.1	Request for registration	16
3.2	Information identifying the applicant.....	17
3.3	Representation of the design suitable for reproduction.....	17
3.3.1	General requirements.....	17
3.3.2	Neutral background	17
3.3.3	Designs retouched with ink or correcting fluid.....	18
3.3.4	Quality.....	19
3.3.4.1	Fax.....	19

3.3.4.2	E-filing	20
3.3.5	Specimen.....	21
4	Examination of the Substantive Requirements	21
4.1	Compliance with the definition of a design	22
4.1.1	Blueprints, plans for houses or other architectural plans and interior or landscape designs.....	22
4.1.2	Colours per se and combinations of colours	22
4.1.3	Icons	23
4.1.4	Mere verbal elements	23
4.1.5	Music and sounds.....	23
4.1.6	Photographs	23
4.1.7	Living organisms.....	23
4.1.8	Teaching material	23
4.1.9	Concepts.....	24
4.2	Public policy and morality	24
4.2.1	Common principles.....	24
4.2.2	Public policy.....	24
4.2.3	Morality	24
4.3	Objection.....	25
5	Additional Requirements Regarding the Reproduction of the Design	25
5.1	Number of views.....	26
5.2	Consistency of the views.....	27
5.2.1	Complex products.....	28
5.2.2	Details	28
5.2.3	Sets of articles	29
5.2.4	Variations of a design	29
5.2.5	Colours	30
5.2.6	Elements external to the design	31
5.3	Use of identifiers to exclude features from protection	31
5.3.1	Broken lines	32
5.3.2	Boundaries.....	32
5.3.3	Colour shading and blurring	33
5.3.4	Separations.....	33
5.4	Explanatory text, wording or symbols.....	34
5.5	Amending and supplementing views.....	34
5.6	Specific requirements	34
5.6.1	Repeating surface patterns	34
5.6.2	Typographic typefaces	35
6	Additional Elements that an Application Must or May Contain	35
6.1	Mandatory requirements.....	35
6.1.1	Identification of the applicant and its representative	36
6.1.2	Specification of the languages.....	36
6.1.3	Signature	37

6.1.4	Indication of products	37
6.1.4.1	General principles	37
6.1.4.2	The Locarno and EuroLocarno classifications.....	37
6.1.4.3	How to indicate products	38
6.1.4.4	<i>Ex officio</i> change of indication	39
6.1.5	Long lists of products.....	40
6.1.6	Objections to product indications.....	41
6.1.6.1	No product indication.....	41
6.1.6.2	Deficient product indication	41
6.1.6.3	Obvious mismatch.....	41
6.2	Optional elements	41
6.2.1	Priority and exhibition priority	42
6.2.1.1	Priority	42
6.2.1.2	Exhibition priority	47
6.2.2	Description.....	49
6.2.3	Indication of the Locarno Classification	49
6.2.3.1	General principles	49
6.2.3.2	Multiple application and the requirement of 'unity of class'.....	50
6.2.4	Citation of the designer(s)	50
6.2.5	Request for deferment.....	51
6.2.5.1	General principles	51
6.2.5.2	Request for deferment.....	51
6.2.5.3	Request for publication.....	52
6.2.5.4	Observation of time limits	52
6.2.5.5	Deficiencies	53
7	Multiple Applications.....	54
7.1	General principles	54
7.2	Formal requirements applying to multiple applications	54
7.2.1	General requirements.....	54
7.2.2	Separate examination.....	55
7.2.3	The 'unity of class' requirement.....	55
7.2.3.1	Principle.....	55
7.2.3.2	Products other than ornamentation	55
7.2.3.3	Ornamentation.....	56
7.2.3.4	Deficiencies	57
8	Payment of Fees	57
8.1	General principles	57
8.2	Currency and amounts.....	58
8.3	Means of payment, details of the payment and refund.....	58
9	Withdrawals and Corrections	59
9.1	Introduction	59
9.2	Withdrawal of the application	59
9.3	Corrections to the application	60
9.3.1	Elements subject to correction	60
9.3.2	Elements that cannot be corrected.....	60
9.3.3	Procedure for requesting correction	60
9.3.4	Deficiencies	61
10	Registration, Publication and Certificates.....	61

10.1	Registration	61
10.2	Publication.....	62
	10.2.1 General principles.....	62
	10.2.2 Format and structure of the publication	62
10.3	Registration certificate.....	64
11	Corrections and Changes in the Register and in the Publication of Community Design Registrations	64
11.1	Corrections	64
	11.1.1 General Principles	64
	11.1.2 The request for correction	65
	11.1.3 Publication of corrections	66
11.2	Changes in the Register.....	66
	11.2.1 Introduction.....	66
	11.2.2 Surrender of the registered Community design.....	66
	11.2.2.1 General principles	66
	11.2.2.2 Formal requirements for a declaration of surrender	67
	11.2.3 Changes in the name and address of the applicant / holder and / or its representative	68
	11.2.4 Transfers.....	69
	11.2.4.1 Introduction.....	69
	11.2.4.2 Rights of prior use in respect of a registered Community design	69
	11.2.4.3 Fees	69
	11.2.5 Licences.....	69
	11.2.5.1 General principles	69
	11.2.5.2 Registered Community designs.....	69
	11.2.5.3 Multiple applications for registered Community designs.....	70
	11.2.5.4 Fees	70
12	International Registrations	70
12.1	General overview of the Hague System.....	71
	12.1.1 The Hague Agreement and the Geneva Act	71
	12.1.2 Procedure for filing international applications.....	71
	12.1.2.1 Particularities.....	71
	12.1.2.2 Deferment of publication.....	71
	12.1.2.3 Fees	72
	12.1.3 Examination carried out by the International Bureau	72
12.2	The role of the Office as designated office.....	72
	12.2.1 Receipt of the international registration designating the European Union ...	73
	12.2.2 Grounds for non-registrability	73
	12.2.2.1 Compliance with the definition of a design, public policy and morality	73
	12.2.2.2 Time limits	73
	12.2.2.3 Languages.....	74
	12.2.2.4 Professional representation.....	74
	12.2.2.5 Renunciation and limitation	74
	12.2.2.6 Grant of protection.....	75
	12.2.2.7 Refusal.....	75
12.3	Effects of International registrations	75
13	Enlargement and the Registered Community Design	76
13.1	The automatic extension of the Community design to the territories of the new Member States	76

1 Introduction

1.1 Purpose of the Guidelines

The Guidelines explain how, in practice, the requirements of the Community Design Regulation¹ (CDR), the Community Design Implementing Regulation² (CDIR), and the Fees Regulation³ (CDFR) are applied by OHIM's Design Service from the receipt of an application for a registered Community design (RCD) up to its registration and publication. The Office has no competence with regard to **unregistered** Community designs.

The purpose of the Guidelines is to ensure consistency among the decisions taken by the Designs Service and to ensure a coherent practice in file handling. These Guidelines are merely a set of consolidated rules setting out the line of conduct which the Office itself proposes to adopt, which means that, to the extent that those rules comply with the legal provisions of a higher authority, they constitute a self-imposed restriction on the Office, in that it must comply with the rules which it has itself laid down. However, these Guidelines cannot derogate from the CDR, the CDIR or the CDFR, and it is solely in the light of those regulations that the applicant's capacity to file an application to register a Community design must be assessed.

The Guidelines are structured to follow the sequence of the examination process with each section and sub-section constituting a step in the registration proceedings from the receipt of the application up to registration and publication. The General Principles (see paragraph 1.2 below) should be kept in mind throughout the whole examination process.

1.2 General principles

1.2.1 Duty to state reasons

The decisions of the Office must state the reasons on which they are based (Article 62 CDR). The reasoning must be logical and it must not lead to internal inconsistencies.

The Office is, however, not required to give express reasons for its assessment of the value of each argument and each piece of evidence submitted to it, in particular where it considers that the argument or evidence in question is unimportant or irrelevant to the outcome of the dispute (see, by analogy, judgment of 15/06/2000, C-237/98P, 'Dorsch Consult Ingenieurgesellschaft mbH', para. 51). It is sufficient if the Office sets out the

¹ [Council Regulation \(EC\) No 6/2002 of 12 December 2001 on Community Designs](#)), amended by Council Regulation No 1891/2006 of 18 December 2006 amending Regulations (EC) No 6/2002 and (EC) No 40/94 to give effect to the accession of the European Community to the Geneva Act of the Hague Agreement concerning the international registration of industrial designs

² [Commission Regulation \(EC\) No 2245/2002 of 21 October 2002 implementing Council Regulation \(EC\) No 6/2002 on Community designs](#), as amended by Commission Regulation (EC) No 876/2007 of 24 July 2007 amending Regulation (EC) No 2245/2002 implementing Council Regulation (EC) No 6/2002 on Community designs following the accession of the European Community to the Geneva Act of the Hague Agreement concerning the international registration of industrial designs

³ [Commission Regulation \(EC\) No 2246/2002 of 16 December 2002 on the fees](#), as amended by Commission Regulation (EC) No 877/2007 of 24 July 2007 amending Regulation (EC) No 2246/2002 concerning the fees payable to the Office for Harmonization in the Internal Market (Trade Marks and Designs) following the accession of the European Community to the Geneva Act of the Hague Agreement concerning the international registration of industrial designs

facts and legal considerations with decisive importance in the context of the decision (judgment of 12/11/2008, T-7/04, 'Limoncello', para. 81).

Whether the reasoning satisfies those requirements is a question to be assessed with reference not only to its wording, but also to its context and the legal rules governing the matter in question (judgment of 07/02/2007, T-317/05, 'Guitar', para. 57).

1.2.2 Right to be heard

The decisions of the Office shall be based only on reasons or evidence on which the applicant has had an opportunity to present its comments (Article 62 CDR, second sentence).

The right to be heard covers all the factual and legal evidence which form the basis for the act of taking the decision, but it does not apply to the final position which the Office intends to adopt.

The obligation to state reasons has two purposes: to allow interested parties to know the justification for the measure taken so as to enable them to protect their rights and to enable the next instance to exercise their power to review the legality of the decision. Moreover, the obligation to state reasons is an essential procedural requirement, as distinct from the question whether the reasons given are correct, which goes to the substantive legality of the contested measure (judgment of 27/06/2013, T-608/11, 'Instrument for writing II', para. 67-68 and the case law cited there).

1.2.3 Compliance with time limits

Applicants must respond to the Office's communications within the time limits set by those communications.

Any written submission or document that has not been submitted within the time limits set by the Office is belated. The same applies to supplementary materials attached only to the confirmation copy of a letter that was in itself sent on time (usually by fax), where this confirmation mail arrives after the expiry of the time limit. This is irrespective of whether such materials are specifically mentioned in the initial letter (for specific rules as regards applications filed by fax, see paragraph 2.7.2.3.).

The Office may disregard facts or evidence which the applicant does not submit in due time (Article 63(2) CDR).

For calculation of time limits see Article 56 CDIR.

A request to extend a time limit by an applicant has to be made before its expiry (Article 57(1) CDIR).

As a general rule, a first request to extend a time limit will be granted. Further extensions will not automatically be granted. Reasons in support of any further request for extension must be submitted to the Office. The request for extension of the time limit must indicate the reasons why the **applicant** cannot meet the deadline. The obstacles faced by the parties' **representatives** do not justify an extension (see, by analogy, order of 05/03/2009, C-90/08 P, 'Corpo Livre', paras 20-23).

The extension cannot result in a time limit longer than six months (Article 57(1) CDR). The applicant is informed about any extension.

Applicants failing to observe the time limits run the risk that their observations may be disregarded, which may result in a loss of rights. In such a case, the applicant may file a request for *restitutio in integrum* (Article 67 CDR. See also the Guidelines Concerning Proceedings before the Office for Harmonization in the Internal Market (Trade Marks and Designs), Part A, Section 8, *Restitutio in integrum*).

1.2.4 Scope of the examination carried out by the Office

When examining an application for a Community design, the Office shall examine the facts of its own motion (Article 63(1) CDR).

The examination procedure is kept to a minimum, that is, mainly an examination of the formalities. However, the grounds for non-registrability foreseen at Article 47 CDR must be examined ex officio by the Office:

- (a) whether the subject-matter of the application corresponds to the definition of a design as set forth in Article 3(a) CDR; and
- (b) whether the design is contrary to public policy or accepted principles of morality.

Where one of these two grounds is applicable, the procedure explained below in paragraph 4 will apply.

Other protection requirements are not examined by the Office. A Community design which has been registered in breach of the protection requirements laid down in Article 25(1)(b) to (g) CDR is liable to be invalidated if an interested party files a request for a declaration of invalidity (see the Guidelines on Examination of Design Invalidity Applications).

1.2.5 User-friendliness

One of the fundamental objectives of the CDR is that the registration of Community designs should present the minimum cost and difficulty to applicants, so as to make it readily available to any applicant including small and medium-sized enterprises and individual designers.

To that end, examiners are encouraged to contact the applicant or, if a representative has been appointed (see paragraph 2.5 below), its representative by phone, in order to clarify issues arising from the examination of an application for a Community design, before or after an official deficiency letter has been sent.

2 Filing an Application at OHIM

2.1 Introduction

There are two ways of applying for registration of a Community design, that is, (i) either via a direct filing, at the Office or at the central industrial property office of a Member State or, in Benelux countries, at the Benelux Office for Intellectual Property (BOIP)

(Article 35 et seq. CDR) or (ii) via an international registration filed with the International Bureau of the World Intellectual Property Organisation and designating the European Union (Article 106a et seq. CDR).

This section will deal with direct filings. The examination of the formalities relating to international registrations designating the European Union will be explained in paragraph 12.

2.2 Form of the application

2.2.1 Different means of filing

An application for a registered Community design may be directly filed at the Office by fax, post, personal delivery or e-filing. It may also be filed at the central industrial property office of a Member State or in Benelux countries, at the Benelux Office for Intellectual Property (BOIP) (Article 35 CDR).

2.2.2 Use of the official form

The Office provides a form (Article 68(1)(a) CDIR) which may be downloaded from the Office's website⁴. The use of the form is not mandatory but it is strongly recommended (Article 68(6) CDIR), in order to facilitate the processing of the application and to avoid errors.

Applicants may use forms of a similar structure or format, such as forms generated by computers on the basis of the information contained in the official form.

2.2.3 Applications sent by post or personal delivery

Applications can be sent to the Office by ordinary post or private delivery services at the following address:

Office for Harmonization in the Internal Market
Avenida de Europa, 4
E-03008 Alicante
SPAIN

Applications can also be handed in personally at the reception of the Office from Monday to Friday, except on official holidays, from 08.30 to 13.30 and from 15.00 to 17.00.

The application has to be signed by the applicant or its representative. The name of the signatory must be indicated and the authority of the signatory must be specified (see paragraph 6.1.3 Signature).

⁴ <https://oami.europa.eu/ohimportal/en/forms-and-filings>

2.2.4 E-filing

E-filing is a recommended means of filing to the extent that the system gives guidance to the applicant, thus reducing the number of potential deficiencies and speeding up the examination procedure.

Where a communication is sent to the Office by electronic means, the indication of the sender's name will be deemed to be equivalent to the signature (see paragraph 6.1.3 Signature).

2.2.5 Fax

Applications can be sent by fax to the following fax number: +34 96 513 1344.

However, filing an application by fax is not recommended because the quality of the representation of the design may deteriorate in the course of the transmission or on receipt by the Office.

Moreover, applicants must be aware of the fact that the processing of their application will be delayed by up to **one month** (see paragraph 2.7.2.3).

2.3 Content of the application

The application must satisfy all the mandatory requirements set out in Articles 1 ('content of the application'), 3 ('indication of products'), 4 ('representation of the design') and 6 CDIR ('fees for the application').

Additional requirements apply where the applicant selects one of the following options: a multiple application is filed (Article 2 CDIR), specimens are filed (Article 5 CDIR), a priority or an exhibition priority is claimed (Article 8 and 9 CDIR), or where the applicant chooses to be, or must be, represented (Article 77 CDR).

2.4 Language of the application

The application may be filed in any of the official languages of the European Union (language of filing) (Article 98(1) CDR; Article 1(1)(h) CDIR)⁵.

The applicant must indicate a second language which must be a language of the Office that is, Spanish (ES), German (DE), English (EN), French (FR) or Italian (IT). The second language must be different from the language of filing.

⁵ The European Union has 24 official and working languages, including Irish. Irish became a full EU language on 01/01/ 2007. There is however a temporary derogation for a renewable period extending until 31/12/2016 during which 'the institutions of the European Union shall not be bound by the obligation to draft all acts in Irish and to publish them in that language in the *Official Journal of the European Union*' (see Council Regulation (EC) No 920/2005 of 13/06/2005 (OJ L 156, 18.6.2005, p. 3) and Council Regulation (EU) No 1257/2010 (OJ L 343, 29/12/2010, p. 5). Until then, it is not possible to file an application for a registered Community design in Irish. Croatian became an official language on 01/07/2013(see paragraph 13).

All written communications have to be drafted in the language of filing, unless the first language chosen is not one of the five working languages of the Office and the applicant agrees to receive the communication in the second language of the application. The consent to the use of the second language must be given for each individual application for a Community design. It may not be given for all existing or future files.

This language regime applies throughout the application and examination procedure until registration.

2.5 Representation of the applicant

2.5.1 When is representation mandatory?

Where the applicant does not have its domicile or its principal place of business or a real and effective industrial or commercial establishment in the European Union, it must be represented by a representative in all proceedings before the Office other than in filing an application (Article 77(2) CDR, Article 10(3)(a) CDIR).

If this requirement is not complied with, the applicant will be requested to appoint a representative within a time limit of two months. Where the applicant does not comply with the request, the application is rejected as inadmissible (Art. 77(2) CDR; Art. 10(3)(a) CDIR).

In examining whether an applicant has a real and effective industrial or commercial establishment in the European Union, the Office follows the guidance of the Court of Justice of 22/11/1978, C-33/78, 'Somafer SA', para. 12 ('... the concept of branch, agency or other establishment implies a place of business which has the appearance of permanency, such as the extension of a parent body, has a management and is materially equipped to negotiate business with third parties ...'). Proof that an applicant has a real and effective industrial or commercial establishment in the European Union may consist, inter alia, of articles of incorporation, annual reports, statements in writing, and other business documents.

2.5.2 Who may represent?

Representation of applicants before the Office may be effected only by a legal practitioner or by a professional representative who fulfills the requirements of Article 78(1) CDR.

A natural or legal person whose domicile, principal place of business, or real and effective industrial or commercial establishment is in the European Union may act before the Office through an employee. Employees of such a legal person may also represent another legal person having neither its domicile nor its principal place of business nor a real and effective industrial or commercial establishment within the European Union, provided there exist economic connections between the two legal persons (Article 77(3) CDR). The Office may request evidence in this respect.

Employees acting on behalf of natural or legal persons pursuant to Article 77(3) CDR must submit a signed authorisation for insertion in the file (Article 62(2) CDIR).

2.6 Date of receipt, file number and issue of receipt

2.6.1 Applications filed through national offices (Intellectual Property Office of a Member State or Benelux Office for Intellectual Property (BOIP))

If a Community design application is filed at the central industrial property office of a Member State or at the Benelux Office for Intellectual Property (BOIP), it will have the same effect as if it has been filed at the Office on that same day, provided that it is received at the Office within two months from the date it was filed at the national office or, as the case may be, the Benelux Office for Intellectual Property (BOIP) (Article 38(1) CDR).

If the Community design application does not reach the Office within this two-month time limit, it will be deemed to have been filed on the date that it is received by the Office (Article 38(2) CDR).

Where the Community design application is received shortly after the expiry of this two-month period, the examiner will check whether this time limit is to be extended under one of the conditions provided for at Article 58(3) CDR.

2.6.2 Applications received directly at the Office

The date of receipt is the date on which the application reaches the Office. This date may not coincide with the 'date of filing' where the requirements for such a date to be allocated are not met (see paragraph 3).

The Office is open for the receipt of applications sent by post or private delivery services from Monday to Friday, except on official holidays. An annual decision of the President of the Office specifies the days on which the Office is not open for the receipt of documents and on which ordinary post is not delivered.

Applications sent by fax or e-filing will be received on the date of successful transmission.

Where the application is sent by post or fax, the applicant will not have any confirmation of a date of receipt or file number until a first communication from an examiner is received (see below).

For electronically filed Community design applications, the system issues an immediate automatic filing receipt which appears on the screen of the computer from which the application was sent. In principle, the applicant should save or print out the automatic receipt. The Office will not send an additional receipt. Receipts for electronically filed applications already contain their provisional filing dates and the file number.

2.7 Registration or examination report

2.7.1 Registration

If the application for a Community design satisfies all requirements for registration, it will normally be registered within **ten working days**.

The registration of an application complying with all requirements may, however, be delayed where the indication of the products in which the design is intended to be incorporated, or to which it is intended to be applied, was not made by reference to the list of products included in the EuroLocarno database available on the website of the Office (<https://oami.europa.eu/eurolocarno/>). In such a case, the indication of the products may have to be sent for translation into the official languages of the Union (see paragraph 6.1.4.4).

An application complying with all registration requirements can be registered within **two working days** if the following conditions are met:

- the application is filed electronically (e-filing)
- both the indication of product(s) and its/their classification are made by using the EuroLocarno system (see paragraph 6.1.4.4)
- priority documents, where a priority is claimed, are included with the e-filing application
- the owner and the representative, if any, are registered in OHIM's database and reference is made to the Office's internal ID number
- fees are to be debited from a current account with the Office or paid by credit card
- no deficiency is found in the application.

2.7.2 Examination report and informal communication on possible deficiencies ('preliminary examination report')

Where a deficiency has been detected in the application, the examiner will issue an examination report summing up the irregularities noted and giving a time limit for the applicant, or the appointed representative, to remedy them.

Before sending such an examination report, the examiner can send an informal communication, called 'preliminary examination report', highlighting some potential deficiencies and aiming at speeding up the examination procedure. This informal communication informs the applicant that the examination procedure is pending due to any of the following circumstances.

2.7.2.1 Priority claims and supporting documents

Where the application contains a claim of priority of one or more previous applications without submitting a certified copy thereof, the applicant may still submit a copy within three months of the filing date (Article 42 CDR; Article 8(1) CDIR; see paragraph 6.2.1.1 below).

In such circumstances, the examiner will inform the applicant that the examination of the application will be put on hold until the missing certified copy of the previous application(s) is submitted. The examination will proceed **three months** after the filing date, unless a copy of the previous application(s), or a declaration that the priority claim is withdrawn, is received earlier.

2.7.2.2 Priority claims made subsequent to the filing

Where the applicant states in the application its intention to claim the priority of one or more previous applications without submitting any details about them, it may still submit, within one month of the filing date, the declaration of priority, stating the date on which, and the country in or for which, the previous application was made (Article 42 CDR; Article 8(2) CDIR; see paragraph 6.2.1.1 below).

In such circumstances, the examiner will inform the applicant that the examination of the application will be put on hold until the missing information is submitted. The examination will proceed **one month** after the filing date, unless a declaration of priority, or a declaration that the priority claim is withdrawn, is received earlier.

2.7.2.3 Application filed by fax

Where an application is filed by fax, the examiner will inform the applicant that the examination will proceed **one month** after the date of receipt of the fax unless a confirmation copy of the application is received earlier by post, private delivery services or personal delivery.

This course of action attempts to avoid situations in which the examination is carried out on the basis of a faxed representation of a design which does not fully disclose all of its features (such as colours) or whose quality is not optimal.

2.7.2.4 Payment of fees

All fees (that is, the registration and publication fees and additional fees in the event of multiple applications) relating to an application must be paid at the time when the application is submitted to the Office (Article 6 CDIR; see paragraph 8 below).

Lack of payment or unidentified payment

Where the application has not yet been linked with a payment of the corresponding fees, the examiner will inform the applicant that the examination will proceed as soon as the payment has been identified and linked to this specific application.

If the applicant does not respond to the Office's communication, and the payment remains unidentifiable, a deficiency letter will be sent.

Lack of funds

Where the full amount of the fees relating to the application cannot be debited from the current account due to insufficient funds, the examiner will inform the applicant that the examination will begin as soon as the current account has been credited with the missing amount.

If the applicant does not respond to the Office's communication, and the payment remains incomplete, a deficiency letter will be sent.

The above also applies to credit card payments where the transaction fails due to reasons not attributable to the Office. In such cases, the applicant will have to use another method of payment.

For more information on the payment of fees, see paragraph 8 below.

2.7.2.5 Multiple applications and request for partial deferment

Where a multiple application contains a request for deferment in respect of *some* designs (see paragraph 6.2.5 below), the examiner will send the applicant a summary of the application containing a representation of the first view of each design to be published without delay. The applicant will be requested to confirm the correctness of this summary within one month. In the absence of any reply or contrary instruction from the applicant, the examination will proceed on the basis of the information on file.

3 Allocation of a Filing Date

The date on which a document is 'filed' is the date of receipt by the Office rather than the date on which this document was sent (Article 38(1) CDR, Article 7 CDIR).

Where the application has been filed at the central industrial property office of a Member State or at the Benelux Office for Intellectual Property (BOIP), the date of filing at that office will be deemed the date of receipt by the Office, unless the application reaches the Office more than two months after such date. In this case, the date of filing will be the date of receipt of the application by the Office (Article 38 CDR).

Pursuant to Article 36(1) CDR, the allocation of a filing date requires that the application contain at least:

- (a) a request for registration of a Community design, and
- (b) information identifying the applicant, and
- (c) a representation of the design suitable for reproduction pursuant to Article 4(1)(d) and (e) CDIR or, where applicable, a specimen (Article 10 CDIR).

Payment of fees is not a requirement for allocating a filing date. It is, however, a requirement for the registration of the application (see paragraph 8 below).

3.1 Request for registration

A request for registration is filed where the applicant has completed (at least partly) the application form provided by the Office or its own form, or made use of e-filing (see paragraph 2.2 above).

Where it is obvious that the document received from the applicant is not an application for a Community design, but an application for registration of a **Community trade mark**, the examiner will forward this document to the competent department of the Office and the examiner will inform the applicant accordingly without delay.

3.2 Information identifying the applicant

The information identifying the applicant, for the purpose of allocating a filing date, does not have to satisfy all the requirements set out in Article 1(1)(b) CDIR (see paragraph 6.1.1). It is enough that information is supplied regarding the surname and forename(s) of natural persons or the corporate name of legal entities, and that an address for service be indicated or any other data communication link which allows the applicant to be contacted.

3.3 Representation of the design suitable for reproduction

3.3.1 General requirements

The representation of the design shall consist of a graphic and/or photographic reproduction of the design, either in black and white or in colour (Article 4(1) CDIR).

Irrespective of the form used for filing the application (paper, e-filing, or fax), the design must be reproduced on a **neutral background** and **must not be retouched** with ink or correcting fluid.

It must be of a quality permitting all the details of the matter for which protection is sought to be clearly distinguished and permitting it to be reduced or enlarged to a size no greater than 8 cm by 16 cm per view for entry in the Register of Community Designs and for publication in the Community Designs Bulletin (Article 4(1)(e) CDIR).

The purpose of that requirement is to allow third parties to determine with accuracy all the details of the Community design for which protection is sought.

Drawings, photographs (except slides), computer-made representations or any other graphical representation are accepted provided they are suitable for reproduction, including on a registration certificate in paper format. 3D computer-animated design generating motion simulation is not accepted for that very reason. CD-ROMs and other data carriers are not accepted.

3.3.2 Neutral background

The background in a view is considered neutral as long as the design shown in this view is clearly distinguishable from its environment without interference from any other object, accessory or decoration, whose inclusion in the representation could cast doubt on the protection sought (decision of 25/04/2012, R 2230/2011-3 – ‘Webcams’, paras 11-12).

In other words, the requirement of a neutral background neither demands a ‘neutral’ colour nor an ‘empty’ background (see also paragraph 5.2.6 below). It is instead decisive that the design stands out so clearly from the background that it remains identifiable (decision of 25/01/2012, R 284/2011-3 – ‘Tool chest’, para. 13).

The views, among the seven allowed for representing a design (Article 4(2) CDIR), which do not have a neutral background will be objected to.

The examiner will issue a deficiency letter. The examiner will give the applicant the possibility to remedy the deficiencies within a two-month period by:

- withdrawing those views (which will not form part of the Community design); or
- submitting new views on a neutral background



or

- amending the objected views in such a way that the design will be isolated from its background. This latter option will make use of identifiers such as boundaries or colour shading clarifying the features of the design for which protection is sought (see paragraph 5.3 below), as in the seventh view of RCD 2038216-0001 (courtesy of BMC S.r.l.):



Provided the deficiencies are remedied within the time limit set by the Office, the date on which all the deficiencies are remedied will determine the date of filing (Article 10(2) CDIR).

If the deficiencies are not remedied within the time limit set by the Office, the application will not be dealt with as a Community design application. The file will be closed by a decision of the examiner and the applicant will be notified. The examiner will notify the Finance Department that a refund of any fees paid should be made to the applicant (Article 10(2) CDIR).

3.3.3 Designs retouched with ink or correcting fluid

The design shall not be retouched with ink or correcting fluid (Article 4(1)(e) CDIR).

Examiners do not see the paper version of the representation but only scanned representations thereof. Therefore, it is only where the use of ink or correcting fluid leaves doubt as to whether the visible correction is or not an ornamental feature

forming part of the design, that corrected representations will be objected to and refused for the purpose of allocating a filing date.

The applicant may remedy a deficiency in the same manner as described above under paragraph 3.3.2.

3.3.4 Quality

The requirement that the design must be of a quality permitting all the details of the matter for which protection is sought to be clearly distinguished, for publication purposes, applies equally to all applications, irrespective of the means of filing.

Applications sent by fax and e-filing, however, raise specific issues.

3.3.4.1 Fax

Transmission by telecopy (fax) may not be appropriate for filing design applications, because the representation of the design may be distorted or blurred or otherwise damaged. Where an application is transmitted by fax, it is highly recommended that a paper confirmation copy be filed without delay, by ordinary mail, private delivery services or personal delivery.

Where an application is transmitted by fax, the examiner will in any event await a confirmation copy for a period of up to one month from the date of receipt of the fax transmission before further processing the application. Once this period has lapsed, the examiner will continue the examination on the basis of the documents on file.

Two deficiencies caused by unsatisfactory fax transmissions may arise:

- (i) the reproduction of a design as transmitted by fax is not of a quality permitting all the details of the matter for which protection is sought to be clearly distinguished
- (ii) the application is incomplete and/or illegible.

As far as the issue of allocating a filing date is concerned, these two hypotheses must be distinguished.

The Office distinguishes an illegible transmission from one of insufficient quality as follows. Where a comparison between the initial transmission and the original reproduction allows drawing a conclusion on whether these documents relate to the representation of one and the same design, it must be considered that the initial transmission was merely of insufficient quality. Where such a comparison is not possible at all, the initial transmission was illegible.

- (i) The reproduction of a design as transmitted by fax is not of a quality permitting all the details of the matter for which protection is sought to be clearly distinguished

The original date of filing will be retained if the applicant sends on its own motion or in reply to the Office's informal communication (see paragraph 2.7.8 above) the original reproduction of the design within **one month** following the fax transmission, provided its quality permits all the details of the matter for which protection is sought to be clearly distinguished (Article 66(1), second paragraph, CDIR).

The confirmation copy has to consist of the same document which was used initially for the fax transmission. The examiner will reject a 'confirmation copy' which is not strictly identical to the document which was used for the fax transmission. This would be the case for instance if the applicant submitted in its confirmation amended views or additional views of the design(s).

In the event of any discrepancy between the original and the copy previously submitted by fax, only the submission date of the original will be taken into consideration.

If no original reproduction is received within the one-month time limit following the receipt of the fax, the Office will send a formal notification inviting the applicant to submit the original reproduction within a two-month period.

If that request is complied with in due time, the date of filing will be the date on which the Office receives the original reproduction, provided its quality permits all the details of the matter for which protection is sought to be clearly distinguished (Article 66(1), third paragraph, CDIR).

If the deficiencies are not remedied within the time limit set by the Office in its notification, the application will not be dealt with as a Community design application. The file will be closed by a decision of the examiner and the applicant will be notified. The examiner will notify the Finance Department that a refund of any fees paid should be made to the applicant (Article 10(2) CDIR).

Where the Office receives a reproduction of a design where **some of the views** are deficient due to fax transmission and where the confirmation copy is received later than one month after the date of receipt of the fax transmission, the applicant will be left with the choice of

- having as the date of filing the date of receipt of the confirmation copy; or
- keeping the date of receipt of the fax transmission as the date of filing, but only for the non-deficient views; in such a case, the deficient views will be withdrawn.

(ii) The application is incomplete and/or illegible.

In the case where the fax was incomplete or illegible and where the missing or illegible parts concern the information identifying the applicant or the representation of the design, the Office will issue a formal notification requesting the applicant to resend the application by fax, post or personal delivery within a **two-month** time limit. If that request is complied with in due time, the date of filing will be the date on which the Office receives the complete and legible documents (Article 66(2) CDIR).

If the deficiencies are not remedied within the time limit set by the Office, the application will not be dealt with as a Community design application. The file will be closed by a decision of the examiner and the applicant will be notified. The examiner will notify the Finance Department that a refund of any fees paid should be made to the applicant (Article 10(2) CDIR).

3.3.4.2 E-filing

The representation of the design must be filed as an attachment to the electronic application form. Each view must be filed as a **single attachment** to the electronic application form and must be in .jpeg data format. The size of each attachment cannot

exceed five MB (see Decision No EX-11-3 of the President of the Office, of 18/04/2011, concerning electronic communication with and by the Office).

Low resolution attachments are likely to be objected to due to their insufficient quality for reproduction and publication purposes where the enlargement of the views to a size of 8 cm by 16 cm causes the details of the design to be blurred.

Where it is clear that the electronic filing was deficient due to technical problems attributable to the Office, such as the partial uploading of all views, the Office will allow the applicant to resubmit the missing views (or all views) by letter, attaching a copy of the e-filing receipt. The original filing date via e-filing will be retained, provided that no other deficiency affecting the filing date exists.

3.3.5 Specimen

The graphic or photographic reproduction of the design can be substituted by a specimen of the design provided the following cumulative conditions are met:

- the application relates to a two-dimensional design, and
- the application contains a request for deferment (Article 36(1)(c) CDR; Article 5(1) CDIR).

In the event of a multiple application, the substitution of the representation by a specimen may apply only to some of the designs, provided these designs are two-dimensional and are subject to a request for deferment (see paragraph 6.2.5 below).

A specimen is usually a sample of a piece of material such as textile, wallpaper, lace, leather, etc.

Specimens must not exceed 26.2 cm x 17 cm in size, 50 grams in weight or 3 mm in thickness. They must be capable of being stored and unfolded (Article 5(2) CDIR).

Five samples of every specimen must be filed; in the case of a multiple application, five samples of the specimen must be filed for each design (Article 5(3) CDIR).

The application and the specimen(s) have to be sent in a single delivery either by post or personal delivery. A date of filing will not be accorded until both the application and the specimen(s) have reached the Office.

Where the applicant submits a specimen relating to an application which does not contain a request for deferment, the specimen is not admissible. In such a case, the date of filing will be determined by the date on which the Office receives a suitable graphic or photographic reproduction of the design, provided the deficiency is remedied within two months of receipt of the Office's notification (Article 10(2) CDIR).

4 Examination of the Substantive Requirements

The Office carries out an examination of the substantive protection requirements which is limited to two absolute grounds for refusal.

An application will be refused if the design does not correspond to the definition provided for in Article 3(a) CDR or if it is contrary to public policy or to accepted principles of morality (Article 9 CDR).

4.1 Compliance with the definition of a design

A 'design' means the appearance of the whole or a part of a product resulting from the features of, in particular, the lines, contours, colours, shape, texture and / or materials of the product itself and / or its ornamentation (Article 3(a) CDR).

A 'product' means any industrial or handicraft item, including, inter alia, parts intended to be assembled into a complex product, packaging, get-up, graphic symbols and typographic typefaces, but excluding computer programs (Article 3(b) CDR).

Whether the product claimed is actually made or used, or can be made or used, in an industrial or handicraft manner will not be examined.

Whether a design discloses the appearance of the whole or a part of a 'product' will be examined in the light of the design itself, in so far as it makes clear the nature of the product, its intended purpose or its function, and of the indication of the products in which the design is intended to be incorporated or to which it is intended to be applied (Article 36(2) CDR).

The following examples, albeit non-exhaustive, illustrate the Office's practice.

4.1.1 Blueprints, plans for houses or other architectural plans and interior or landscape designs

Blueprints, plans for houses or other architectural plans and interior or landscape designs (e.g. gardens) will be considered 'products' for the purpose of applying Article 7(1) CDR and will be accepted only with the corresponding indication of 'printed matters' in Class 19-08 of the Locarno Classification.

An objection will be raised if the product indicated in an application for a design consisting of a blueprint of a house is 'houses' in Class 25-03 of the Locarno Classification. This is because a blueprint does not disclose the appearance of a finished product such as a house.

4.1.2 Colours per se and combinations of colours

A single colour may of course be an element of a design, but on its own it does not comply with the definition of a design because it does not constitute the 'appearance of a product'.

Combinations of colours may be accepted if it can be ascertained from the contours of the representation that they relate to a product such as, for instance, a logo or a graphic symbol in Class 32 of the Locarno Classification.

4.1.3 Icons

Designs of screen displays and icons and other kinds of visible elements of a computer program are eligible for registration (see Class 14-04 of the Locarno Classification).

4.1.4 Mere verbal elements

Mere words per se and sequences of letters (written in standard characters in black and white) do not comply with the definition of a design because they do not constitute the appearance of a product.

The use of fanciful characters and/or the inclusion of a figurative element, however, render(s) the design eligible for protection either as a logo / graphic symbol in Class 32 of the Locarno Classification, or as the ornamental representation of a part of any product to which the design will be applied.

4.1.5 Music and sounds

Music and sounds per se do not constitute the appearance of a product and, therefore, do not comply with the definition of a design.

However, the graphical representation of a musical composition, in the form of a musical string, would qualify as a design, if applied for as, for example, *other printed matter* in Class 19-08 or *graphic symbols* in Class 32 of the Locarno Classification.

4.1.6 Photographs

A photograph per se constitutes the appearance of a product and, therefore, complies with the definition of a design, irrespective of what it discloses. The indication of the product can be *writing paper, cards for correspondence and announcements* in Class 19-01, *other printed matters* or *photographs* in Class 19-08 of the Locarno Classification, or any product to which the design will be applied.

4.1.7 Living organisms

Living organisms are not 'products', that is, industrial or handicraft items. A design which discloses the appearance of plants, flowers, fruits etc. in their natural state will, in principle, be refused. Even if the shape at issue deviates from that of the common corresponding living organism, the design should be refused if nothing suggests prima facie that the shape is the result of a manual or industrial process (see by analogy decision of 18/02/2013, R 0595/2012-3 – 'Groente en fruit', para. 11). However, no objection will be raised if the indication of the product specifies that this product is artificial (see in particular Class 11-04 of the Locarno Classification).

4.1.8 Teaching material

Teaching material such as graphs, charts, maps etc. can be representations of products in Class 19-07 of the Locarno Classification.

4.1.9 Concepts

A design application is refused where the representation is of a product that is simply one example amongst many of what the applicant wishes to protect. An exclusive right cannot be granted to a 'non-specific' design that is capable of taking on a multitude of different appearances. This is the case where the subject-matter of the application relates, inter alia to a concept, an invention or a method for obtaining a product.

4.2 Public policy and morality

4.2.1 Common principles

The concepts of public policy and morality may vary from one country to another. A restrictive measure based on public policy or morality may be based on a conception which is not necessarily shared by all Member States (judgment of 14/10/2004, C-36/02, 'Omega', paras 33 and 37).

Given the unitary character of the registered Community design (Article 1(3) CDR), it is enough that a design be found contrary to public policy in at least part of the Union for this design to be refused under Article 9 CDR (see, by analogy, judgment of 20/09/2011, T-232/10, 'Coat of arms of the Soviet Union', paras 37 and 62). This finding can be supported by the legislation and administrative practice of certain Member States.

It is not necessary that the use of the design would be illegal and prohibited. However, illegality of the use of the design under European or national legislation is a strong indication that the design should be refused under Article 9 CDR.

4.2.2 Public policy

The safeguard of public policy may be relied on to refuse a Community design application only if there is a genuine and sufficiently serious threat to a fundamental interest of society (judgment of 14/03/2000, C-54/99, 'Église de scientologie', para. 17).

Designs which portray or promote violence or discrimination based on sex, racial or ethnic origin, religion or belief, disability, age or sexual orientation will be refused on that account (Article 10 of the Treaty on the Functioning of the European Union).

4.2.3 Morality

The safeguard of morality may be relied on to refuse a Community design application if the design is perceived as sufficiently obscene or offensive from the perspective of a reasonable person of normal sensitivity and tolerance (see, by analogy, judgment of 09/03/2012, T-417/10, '¡Que bueno ye! Hijoputa', para. 21).

Bad taste, as opposed to contrariety to morality, is not a ground for refusal.

4.3 Objection

Where an objection is raised by the examiner in respect of one or the other of the two above absolute grounds for refusal, the applicant will be given the opportunity of withdrawing or amending the representation of the design or of submitting its observations within a two-month time limit (Article 47(2) CDR, Article 11 CDIR).

If the objection relates to the compliance with the definition of a design and if this objection can be overcome by amending the indication of the products in which the design is intended to be incorporated or to which it is intended to be applied, the examiner will propose such an amendment in the communication to the applicant.

Where the applicant opts for submitting an amended representation of the design, this representation will be admissible under the condition that 'the identity of the design is retained' (Article 11(2) CDIR).

Maintenance in an amended form will, therefore, be limited to cases in which the removed or disclaimed features are so insignificant in view of their size or importance that they are likely to pass unnoticed in the perception of the informed user.

Features can be removed or disclaimed by making use of the identifiers referred to in paragraph 5.3 below.

Provided the deficiencies are remedied within the time limit set by the Office, the date on which all the deficiencies are remedied will determine the date of filing (Article 10(2) CDIR).

Where the applicant fails to overcome the grounds for non-registrability within the time limit, the Office will refuse the application. If those grounds concern only some of the designs contained in a multiple application, the Office will refuse the application only in so far as those designs are concerned (Article 11(3) CDIR).

5 Additional Requirements Regarding the Reproduction of the Design

Applicants are reminded that the requirements concerning the format of the representation of the design may vary according to the manner in which the application was filed (paper, e-filing, use of specimen). These requirements are set out in Articles 4 and 5 CDIR.

The following instructions supplement the requirements regarding the quality of the reproduction and the neutral background (see paragraph 3.3 above).

The following instructions apply to all designs, irrespective of the manner in which the application was filed.

Even where a representation of the design has been replaced by a specimen in accordance with Article 5 CDIR (see paragraph 3.3.5 above), the applicant must file a graphic or photographic reproduction of the design at the latest three months before the 30-month deferment period expires (Article 15(1)(c) CDIR; see paragraph 6.2.5.3 below).

Any deficiency found in an application and relating to one or the other of the requirements under this section will have no bearing on the granting of a filing date. However, if the deficiencies are not remedied within the time limit set by the Office in its examination report, the application will be refused (Article 46(3) CDR). If the deficiencies concern only some of the designs contained in a multiple application, the Office will refuse the application only in so far as those designs are concerned (Article 11(3) CDIR).

Once a date of filing has been granted, refusal of the application does not give rise to a refund of the fees paid by an applicant (Article 13 CDIR).

5.1 Number of views

The purpose of the graphic representation is to disclose the features of the design for which protection is sought. The graphic representation must be self-contained, in order to determine with clarity and precision the subject-matter of the protection afforded by the registered Community design to its proprietor. This rule is dictated by the requirement of legal certainty.

It is the responsibility of the applicant to disclose as thoroughly as possible the features of its design. The Office will not examine whether additional views would be required to fully disclose the appearance of the design, with the exceptions listed under paragraphs 5.2.1 to 5.2.3 below.

A maximum of seven different views can be filed in order to represent the design (Article 4(2) CDIR). The views may be plain, in elevation, cross-sectional, in perspective or exploded. Only one copy of each view should be filed.

An exploded view is a view in which all the components of a complex product are shown disassembled in order to explain how these components can be assembled together, as in the example below (RCD 380969-0002, courtesy of Aygaz Anonim Sirketi, designer Zafer Dikmen).

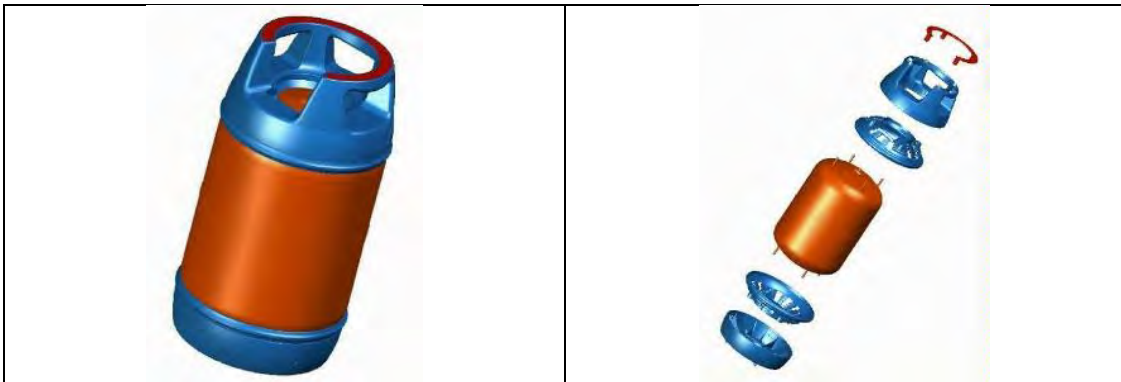

The alternative positions of the moveable or removable parts of a design can be shown in separate views, as in the example below (RCD 588694-0012, courtesy of Fujitsu Toshiba Mobile Communications, designer Hideki Hino).

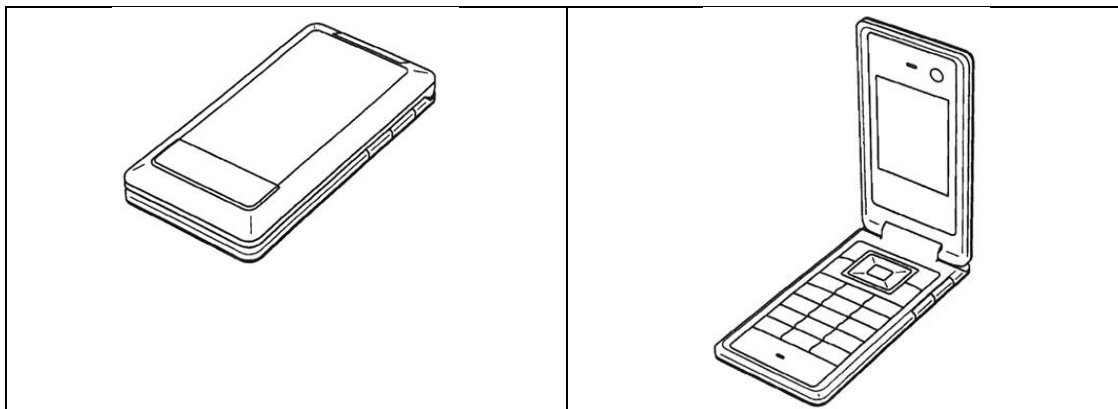

Each of the views must be numbered by the applicant in Arabic numerals by figures separated by a dot, the first being the number of the design, the second being the number of the view. For instance, the 6th view of the second design of a multiple application must be numbered: 2.6.

In cases where more than seven views are provided, the Office will disregard any of the extra views for registration and publication purposes (decision of 27/10/2009, R 571/2007-3 – ‘Frames for cycles or motorcycles’, para. 13). The Office will take the views in the consecutive order in which the views are numbered by the applicant (Article 4(2) CDIR).

Where a reproduction comprises less than seven views and the views are not numbered, the examiner will number the views according to the sequence given in the application.

The examiner will not change the order of the views as appearing in the application, or their orientation.

5.2 Consistency of the views

The examiner will check whether the views relate to the same design, that is, to the appearance of one and the same product or of its parts.

Where the views are inconsistent and relate to more than one design, the applicant will be invited either to withdraw some views or to convert the application into a multiple application for different designs, and pay the corresponding fees.

To submit a correct and complete application (including representations of the design) falls within the applicant’s responsibility. The Office is not entitled to remedy any deficiencies in respect of incongruent views once the Community design is registered and published (see decision of 3/12/2013, R 1332/2013-3 ‘Adapters’, para. 14 et seq.)

The consistency of the views may be particularly difficult to assess when examining applications for designs relating to complex products, to details of products and to sets of articles.

5.2.1 Complex products

A complex product is a product which is composed of multiple components which can be replaced permitting disassembly and re-assembly of the product (Article 3(c) CDR).

Applicants must submit, among the seven views allowed, at least one view showing the complex product in its assembled form. See the example below (RCD 238092-0001 courtesy of Eglo Leuchten GmbH):



Each of the component parts could in themselves be a 'design'. Therefore, where all the views disclose different component parts, **without showing these parts connected to each other**, the examiner will issue a deficiency letter giving the applicant two options:

- the applicant can convert its application into a multiple application combining the separate designs for each component part in question and pay the corresponding fees; or
- the applicant can limit its application to just one design by withdrawing the views representing other designs.

5.2.2 Details

The same reasoning applies to a design which is not intended to be incorporated in a complex product where the views only show individual details which cannot be related to the appearance of the product as a whole.

Each of the individual details of the product could in themselves be a 'design'. Therefore, where all the views disclose different detailed features, **without showing these features connected to each other**, the examiner will issue a deficiency letter giving the applicant two options:

- the applicant can convert its application into a multiple application combining the separate designs for each individual detail in question and pay the corresponding fees; or
- the applicant can limit its application to just one design by withdrawing the views representing other designs.

5.2.3 Sets of articles

A set of articles is a group of products of the same kind which are generally regarded as belonging together and are so used. See the example below (RCD 685235-0001, courtesy of Zaklady Porcelany Stolowej KAROLINA Sp. z o.o.)



The difference between a complex product and a set of articles is that, in contrast to a complex product, the articles of a 'set of articles' are not mechanically connected.

A set of articles can be a 'product' in itself within the meaning of Article 3 CDR. It can be represented in a single design application if the articles making up this set are linked by **aesthetic and functional complementarity** and are, in normal circumstances, sold altogether as one single product, like a chess board and its pieces or sets of knives, forks and spoons.

It must, however, be clear from the representation that protection is sought for a design resulting from the combination of the articles making up the set.

Applicants must submit, among the seven views allowed, at least one view showing the set of articles in its entirety.

Otherwise, the examiner will issue a deficiency letter giving the applicant two options:

- the applicant can convert its application into a multiple application combining the separate designs for each article in question and pay the corresponding fees; or
- the applicant can limit its application to just one design by withdrawing the views representing other designs.

5.2.4 Variations of a design

Sets of products should not be confused with variations of a design. The different embodiments of a same concept cannot be grouped in a single application because each embodiment is a design on its own, as in the example below (RCD 1291652-0001; -0002; -0003; -0004, courtesy of TESCOVA s.r.o.).

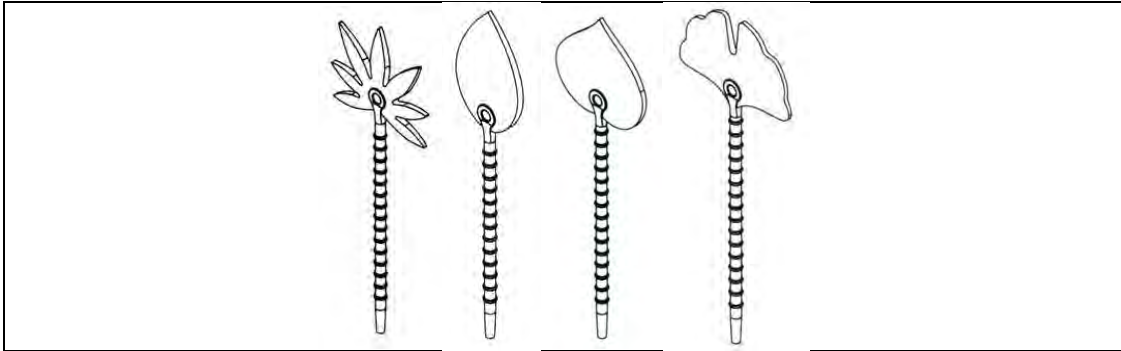

Where, in an application for a single registered Community design, the views relate to more than one design, the examiner will issue a deficiency letter giving the applicant two options:

- the applicant can convert its application into a multiple application combining the separate designs and pay the corresponding fees; or
- the applicant can limit its application to just one design by withdrawing the views representing other designs.

5.2.5 Colours

The representation of the design may be submitted **either** in black and white (monochrome) **or** in colour (Article 4(1) CDIR).

Representations combining black and white views with colour views will be objected to due to their inconsistency and the resulting legal uncertainty as to the protection sought.

The same reasoning applies where the same features of a design are represented in different colours in the various views. Such an inconsistency illustrates the fact that the application relates to more than one design (decisions of 31/03/2005, R 965/2004-3 – ‘Tape measure’, paras 18-20; of 12/11/2009, R 1583/2007-3 – ‘Bekleidung’, paras 9-10).

The applicant will, therefore, be invited either to withdraw some of the colour views in order to maintain consistency between the remaining ones, or to convert the application into a multiple application, and pay the corresponding fees.

However, as an exception to the above principle, the same features of a design can be represented in different colours in the various views if the applicant submits evidence that the change of colours at different points in time, while the product is in use, is one of the relevant features of the design, as in the example below (RCD 283817-0001, courtesy of ASEM Industrieberatung und Vermittlung).

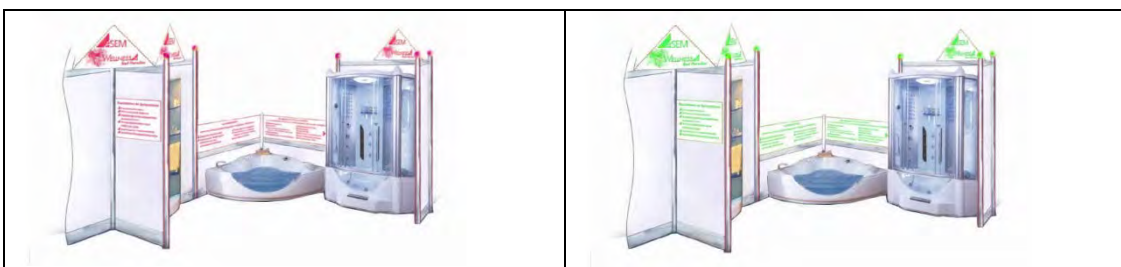

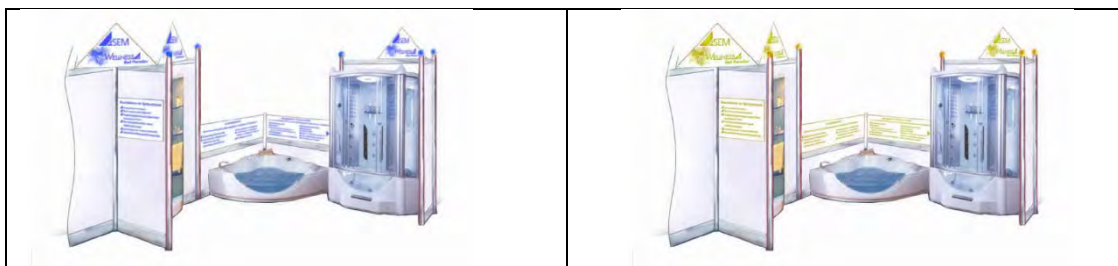

Where the reproduction is in colour, the registration and the publication will also be in colour (Article 14(2)(c) CDIR).

5.2.6 Elements external to the design

Views can include external and foreign matter to the design provided their inclusion does not cast any doubt on the protection sought and serves only an illustrative purpose (see paragraph 3.3.2 above).

See for instance the following two RCDs, No 210166-0003 (courtesy of Karl Storz GmbH & Co. KG) and No 2068692-0002 (courtesy of Tenzi Sp. z o.o.) in which the inclusion of a hand or buildings and vegetation in some of the views serves the purpose of clarifying how the product in which the design is incorporated will be used or the context in which it will be used:



5.3 Use of identifiers to exclude features from protection

Unlike Article 37 CTMR, neither the CDR nor the CDIR provides rules for the possibility of including in the application a statement that the applicant disclaims any exclusive right to one or more features disclosed in the views.

Use of a description, within the meaning of Article 36(3)(a) CDR, is not appropriate in this regard since a description 'shall not affect the scope of protection of the design as such' according to Article 36(6) CDR. Moreover, only an indication that a description has been filed is published, not the description as such (Article 14(2)(d) CDR). Disclaimers must therefore be apparent from the representation of the design itself.

In an application for registration of a Community design the following identifiers will be allowed:

5.3.1 Broken lines

Broken lines may be used in a view either to indicate the elements for which no protection is sought (for example, ornamentation applied to the surface of a given product whose shape is disclaimed) or to indicate portions of the design that are not visible in that particular view, that is, non-visible lines.



5.3.2 Boundaries

Boundaries may be used to surround features of the design for which protection is sought, the remaining parts being considered as having a purely illustrative purpose, that is, to show the environment in which the claimed features are placed.





5.3.3 Colour shading and blurring

Colour shading and blurring may be used to exclude a number of features from protection and thus to highlight claimed features.



5.3.4 Separations

Separations can be used to indicate that, for ease of illustration, the precise length of the design is not claimed (indeterminate length).

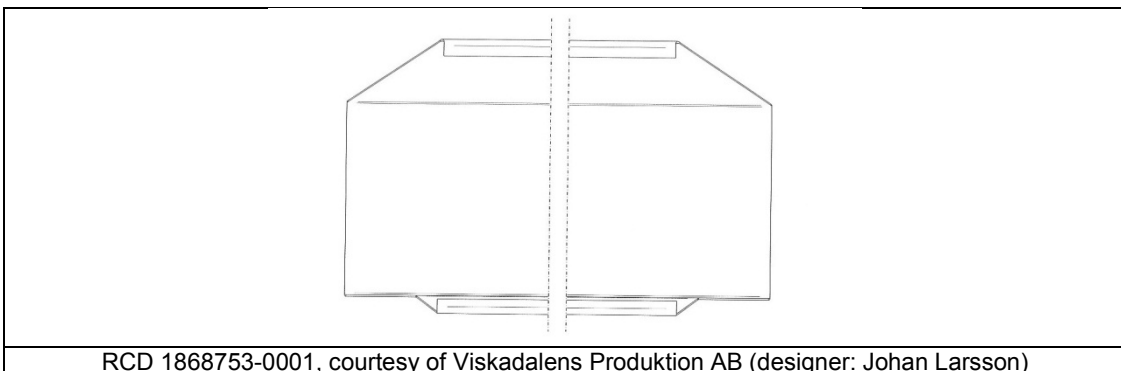

5.4 Explanatory text, wording or symbols

No explanatory text, wording or symbols, other than the indication 'top' or the name or address of the applicant may be displayed in the views (Article 4(1)(c) CDIR).

Where words, letters, numbers and symbols (such as arrows) are clearly not part of the design, the examiner may cut them from the views using the specific informatics tool available for this. If the examiner is not able to cut them out for technical reasons, the applicant will be requested to send in clean views or to withdraw the deficient ones.

Where the words, letters, numbers, etc. are part of the design (graphical symbol), the design is acceptable.

Verbal elements displayed in the representation that are part of the design will be keyed in and entered in the file. Where several verbal elements are displayed, the examiner will only take into account the most prominent one.

Indications such as 'side', 'front view', etc. will be cut for publication purposes. If the applicant considers such indications to be relevant, it may wish to include them in the box 'Description' at the time of filing. Further amendments or the addition of a description will not be allowed.

5.5 Amending and supplementing views

As a matter of principle, the representation may not be altered after the application has been filed. The submission of additional views or the withdrawal of some views will therefore not be accepted (Article 12(2) CDIR), unless expressly allowed or required by the Office.

In particular, the views initially filed may not be replaced with better-quality ones. The representations examined and published will be those that the applicant provided in its original application.

The submission of amended or additional views, where allowed, must be made by electronic communication via the OHIM website (not by e-mail), by post or fax (the latter is, however, not recommended; see paragraph 2.2.5 above).

5.6 Specific requirements

5.6.1 Repeating surface patterns

Where the application concerns a design consisting of a repeating surface pattern, the representation of the design must disclose the complete pattern and a sufficient portion of the repeating surface (Article 4(3) CDIR), in order to show how this pattern is infinitely multiplied.

Where the application does not contain a description making clear that the design consists of a repeating surface pattern, the Office will assume that this is not the case and will not request a sufficient portion of the repeating surface.

If additional views represent the pattern applied to one or more specific products for illustrative purposes, the applicant must make sure that the shape of such products is not claimed as part of the design by using any method referred to under paragraph 5.3 above (RCD 002321232-0002, courtesy of Textiles Visatex SL.):

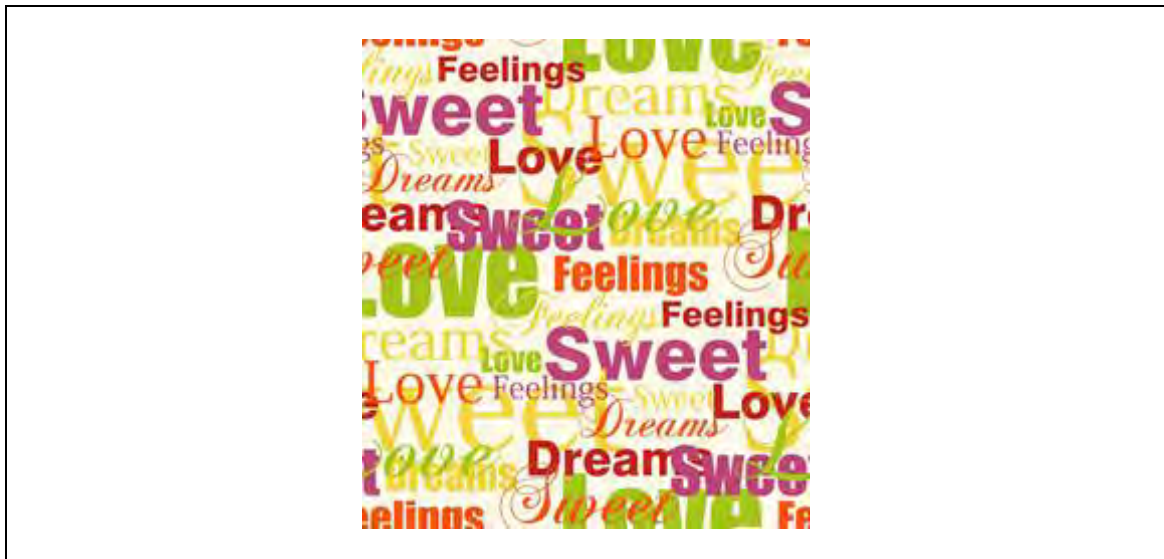

5.6.2 Typographic typefaces

Where the application concerns a design consisting of a typographic typeface, the representation of the design must consist of a string of all the letters of the alphabet, upper case and lower case, and of all the Arabic numerals, as well as of a text of five lines produced using that typeface, all in 16-pitch font (Article 4(4) CDIR).

Where the application does not include a text of five lines using the typeface concerned (Article 4(4) CDIR), the applicant will be requested to submit such a text or to accept a change in the indication of products to 'set of characters' in Locarno Class 18.03.

6 Additional Elements that an Application Must or May Contain

6.1 Mandatory requirements

In addition to the requirements for the grant of a filing date (see paragraph 3 above), the application must properly identify the applicant and, if applicable, its representative (Article 1(b) and (e) CDIR), specify the two languages of the application (Article 1(h) CDIR), contain a signature (Article 1(i) CDIR) and indicate the products in which the design is intended to be incorporated or to which it is intended to be applied (Article 1(d) CDIR).

Even after a date of filing has been granted, the examiner will issue an objection if a deficiency with regard to any of the above requirements is noted in the course of examining the Community design application (Article 10(3)(a) CDIR).

6.1.1 Identification of the applicant and its representative

Pursuant to Article 1(b) CDR, an application will be objected to if it does not contain the following information regarding the applicant: its name, address and nationality and the State in which it is domiciled or, if the applicant is a legal entity, in which it has its seat or establishment. If the Office has given the applicant an identification number, it is sufficient to mention that number together with the applicant's name.

Where the application is filed in the name of more than one applicant, the same requirement applies to each one.

Names of natural persons must give both the family name and the given name(s). Legal entities must be indicated by their official designation. The State whose law governs such entities must also be indicated.

If the applicant does not have a representative, it is highly recommended that an indication be given of telephone numbers as well as fax numbers and details of other data-communications links, such as electronic mail.

Each applicant must, in principle, indicate only one address. Where several addresses are indicated, only the first address mentioned will be taken into account, except where the applicant designates one of the addresses as an address for service.

If there is more than one applicant, the Office will send its communications to the applicant mentioned first in the application.

If the applicant has appointed a representative, the application must indicate the name of that representative and the address of their place of business. If an appointed representative has been given an identification number by the Office, it will be sufficient to mention that number together with the representative's name.

If the representative has more than one business address or if there are two or more representatives with different business addresses, the application must indicate which address is to be used as the address for service. Where no such indication is made, the address for service will be taken to be the first address mentioned.

If there is more than one applicant, the application may appoint one representative to be the common representative for all applicants.

6.1.2 Specification of the languages

The application may be filed in any of the official languages of the European Union (language of filing) (Article 98(1) CDR, see paragraph 2.4). The language used in the application form does not affect the language of the application. It is the language of the content supplied by the applicant that is decisive. The language of filing will be the first language of the application.

The applicant must indicate a second language, which must be an Office language, that is, Spanish (ES), German (DE), English (EN), French (FR) or Italian (IT).

The second language must be different from the language of filing.

The two-letter ISO CODES (codes set up for identifying languages by the International Organisation for Standards) may be used in the box provided in the application form.

6.1.3 Signature

The application must be signed by the applicant or its representative (Article 1(i) CDIR). Where there is more than one applicant or representative, the signature of one of them will be sufficient.

If an application is filed electronically, it is enough for the name and authority of the signatory to be indicated. If an application is filed by fax, a facsimile signature is considered valid.

For representatives, the signature consisting of the name of the law firm is acceptable.

6.1.4 Indication of products

6.1.4.1 General principles

Pursuant to Article 36(2) CDR, an application for a Community design must indicate the products in which the design is intended to be incorporated or to which it is intended to be applied. Pursuant also to Article 1(1)(d) and Article 3(3) CDIR, the indication of products must be worded in such a way as to indicate clearly the nature of the products and to enable each product to be classified in only one class of the Locarno classification, preferably using the terms appearing in the list of products set out therein, or in the EuroLocarno database (see below).

Neither the product indication nor the classification affects the scope of protection of a Community design as such (Article 36(6) CDR). Classification serves exclusively administrative purposes, in particular allowing third parties to search the registered Community designs databases (Article 3(2) CDIR).

Applicants do not themselves have to classify the products in which their design is intended to be incorporated or to which it is intended to be applied (Article 36(3)(d) CDR). This is, however, highly recommended in order to speed up the registration procedure (see paragraph 6.2.3).

The considerations that follow here below only refer to single design applications. As far as multiple design applications are concerned, the 'unitary class' requirement applies (see paragraph 7.2.3).

6.1.4.2 The Locarno and EuroLocarno classifications

The Locarno Classification is an international classification for industrial designs. It exists in two official languages, namely English and French. Its structure and contents are adopted and amended by the Committee of Experts from the countries party to the Locarno Agreement. The Classification is administered by the World Intellectual Property Organization (WIPO). The current, tenth, edition contains 32 classes and 219 subclasses.

EuroLocarno is the Office's design classification tool. It is based on, and has the same structure as, the Locarno Classification (i.e. the same classes and subclasses). It contains the alphabetical list of products of the Locarno Classification and is supplemented by a large number of additional product terms. EuroLocarno is available in all the official languages of the Union at OHIM's website.

In order to speed up and simplify the registration procedure, it is highly recommended that products be indicated using the terms listed in the EuroLocarno database.

Using the terms listed in the EuroLocarno database obviates the need for translations and thus prevents long delays in the registration procedure. Using these product terms whenever possible will improve the transparency and searchability of the registered Community designs databases.

6.1.4.3 How to indicate products

More than one product can be indicated in the application.

When more than one product is indicated in the application, the products do not have to belong to the same class of the Locarno Classification, unless several designs are combined in a multiple application (Article 37(1) CDR; Article 2(2) CDIR; see paragraph 7.2.3).

Each class and subclass of the Locarno Classification and EuroLocarno has a 'heading'. The class and subclass headings give a general indication of the fields to which the products belong.

In any event, the product(s) must be indicated in such a way as to allow classification in both the relevant class and subclass of the Locarno Classification (Article 1(2)(c) CDIR).

The use of terms listed in the heading of a given class of the Locarno Classification is not per se excluded, but it is not recommended. Applicants should **not** choose generic terms referred to in the heading of the relevant class (e.g. 'articles of clothing' in Class 2), but, instead, select terms listed in the heading of the subclass (e.g. 'garments' in subclass 02-02) or more specific terms from among those listed in the subclasses of the class in question (e.g. 'jackets' in subclass 02-02).

Where the product indication does not allow classification in a subclass, the examiner will determine the relevant subclass by reference to the product disclosed in the graphical representation (see paragraph 6.2.3.1 below). For example, where an application contains as a product indication the term 'Furnishing' in Class 6 of the Locarno Classification, the examiner will assign a subclass by taking account of the design itself insofar as it makes clear the nature of the product, its intended purpose or its function. If the design discloses the appearance of a bed, the examiner will assign the subclass 06-02 to the generic indication 'Furnishing'.

The use of adjectives in product indications is not per se excluded, even if such adjectives are not part of the alphabetical list of products of the Locarno Classification or of EuroLocarno (e.g. '**electric** tools for drilling' in subclass 08-01, or '**cotton** pants' in subclass 02-02). However, it may cause delays in processing the application where a translation of the adjective into all the EU languages is required.

6.1.4.4 *Ex officio* change of indication

Product terms not listed in the Locarno Classification or EuroLocarno

Where an applicant uses terms that are not in EuroLocarno, the examiner will, in straightforward cases, substitute *ex officio* the wording used by the applicant with an equivalent or more general term listed in the Locarno Classification or EuroLocarno. The purpose of this is to avoid having to translate terms into all the EU languages, which would result in delays in processing the application.

For instance, where an applicant chooses the term 'Running trainers' (a term not listed in EuroLocarno) to indicate the products in which the design will be incorporated, the examiner will change this indication to 'Footwear' (which is the heading of subclass 02-04) or 'Shoes' (which is listed under subclass 02-04).

Even though the product indication does not affect the scope of protection of a Community design as such, the examiner will refrain from replacing the terms chosen by the applicant with more specific terms.

Products and their parts; sets

Where a design represents the appearance of one part of a product, and that product as a whole is indicated in the application (e.g. an application for the design of a knife handle specifies that the products in which this design will be incorporated are 'knives' in subclass 08-03), the examiner will replace that product indication by the indication 'Product(s) X (Part of -)', provided both the part in question and the product as a whole belong to the same class of the Locarno Classification.

Where a design represents a set of products, and these products are indicated in the application (e.g. an application for the design of a set of dishes specifies that the products in which this design will be incorporated are 'dishes' in subclass 07-01), the examiner will replace that indication by 'Product(s) X (Set of -)'.

Ornamentation

The same reasoning applies where the design represents ornamentation for a given product, and that product as a whole is indicated in the application. The examiner will replace that product indication by the indication 'Product(s) X (Ornamentation for -)'. The product will thus be classified under Class 32-00 of the Locarno Classification.

Moreover, where the product indication is 'Ornamentation' and the design does not limit itself to representing this ornamentation but also discloses the product to which the ornamentation is applied, or part of that product, without its contours being disclaimed, this product will be added to the product indication, and the classification will be amended accordingly.

A list of products combining 'Ornamentation' with other products belonging to different classes of the Locarno Classification will give rise to an objection where several designs are combined in a multiple application (see paragraph 7.2.3.).

Notification of the *ex officio* change of indication

Provided there is no deficiency, the examiner will register the Community design(s) and notify the applicant of the *ex officio* change of product indication.

Where the applicant objects to such *ex officio* change, it can apply for correction of the corresponding entry in the Register (see paragraph 11.1.) and request that the original terms used in the application be maintained, provided there are no issues concerning the clarity and precision of these terms or their classification (Article 20 CDIR; see decision of 05/07/2007, R 1421-2006-3, 'Cash registers'). In this case, however, applicants are informed that translation of the original terms into all official languages of the Union is likely to delay registration of the Community design(s).

6.1.5 Long lists of products

More than one product can be indicated in an application.

However, in order to ensure that the Community designs Register remains searchable and to save translation costs, where an application indicates more than five different products belonging to the same subclass of the Locarno Classification, the examiner will suggest replacing the product indication by the heading of the subclass in question.

For example, let us assume an application contains the following product indication: *Locking or closing devices, Keys for vehicles, Anti-theft interlocking strips for doors, Anti-theft posts for motorcycles, Padlocks (part of -), Keepers of locks, Latches, Handcuffs, Handbag frames, Hasps, Lock bolts, Closing devices for doors and windows, Door openers [electric], Door bolts, Locks, Clasps for purses and handbags, Flat bolts [locks], Padlocks, Locking devices, Clasps for leather goods, Door closers, Casement bolts for windows or doors, Catches for venetian blinds, Keys for electric contacts, Cable-type padlocks for cycles, Theftproof locks, Keys, Box fasteners, Door check brakes, Tumbler locks, Door locks for vehicles, Fastenings for motor truck loading gates, Safety locks for bicycles, Clasps for cigarette cases, Shutter turnbuckles, Wheel clamps [boots], Manacles, Locks (part of -)*.

Since all these products are classified in the same subclass of the Locarno Classification, the examiner will propose replacing this list by the heading of subclass 08-07, that is, 'Locking or closing devices'.

Where the product indication contains more than five products that do not belong to the same subclass of the Locarno Classification, the examiner will suggest that the applicant limit the number of products to five and select products accordingly.

If, within the time limit indicated in the examiner's communication, the applicant expresses its wish to maintain the original list of products, the examination will proceed on the basis of that list.

If the applicant does not respond within the time limit or expressly agrees with the examiner's proposal, the examination will proceed on the basis of the product indication as proposed by the examiner.

6.1.6 Objections to product indications

Where the examiner raises an objection, the applicant will be given two months to submit its observations and remedy any deficiencies noted (Article 10(3) CDIR).

The examiner may invite the applicant to specify the nature and purpose of the products in order to allow proper classification, or may suggest product terms from EuroLocarno in order to assist the applicant.

If the deficiency is not remedied within the time limit, the application will be rejected (Article 10(4) CDIR).

6.1.6.1 No product indication

An objection will be raised where the application gives no indication of the products concerned (Article 36(2) CDR). However, if an indication can be found in the description or in the priority document, the examiner will record this as the product indication (decision of 21/03/2011, R 2432/2010-3, 'Kylkropp för elektronikbärare', para. 14).

6.1.6.2 Deficient product indication

The examiner will also object to the product indication if it does not enable each product to be classified in only one class and subclass of the Locarno classification (Article 3(3) CDIR).

This will be the case where the indication is too vague or ambiguous to allow the nature and purpose of the products in question to be determined, for example *merchandise, novelty items, gifts, souvenirs, home accessories, electric devices, etc.*

This will also be the case where the indication concerns a service rather than a product, for example *sending or processing of information*.

6.1.6.3 Obvious mismatch

Since one of the main objectives of the product indication and classification is to make the Community designs Register searchable by third parties, the examiner will raise an objection where the product indication clearly does not match the product as disclosed in the representation of the design.

6.2 Optional elements

An application may contain a number of optional elements, as listed in Article 1(1)(f) and (g) and Article 1(2) CDIR, that is,

- a priority or exhibition priority claim;
- a description;
- an indication of the Locarno Classification of the products contained in the application;
- the citation of the designer(s);

- a request for deferment.

6.2.1 Priority and exhibition priority

6.2.1.1 Priority

General principles

An application for a Community design may claim the priority of one or more previous applications for the same design or utility model in or for any state party to the Paris Convention or to the Agreement establishing the World Trade Organization, or in or for another State with which there is a reciprocity agreement (Article 41 CDR; Article 8 CDR). This 'Convention priority' is of six months from the date of filing of the first application.

The effect of the right of priority is that the date of priority counts as the date of filing of the application for a registered Community design for the purposes of Articles 5, 6, 7 and 22, Article 25(1)(d) and Article 50(1) CDR (Article 43 CDR).

Priority claims are subject to the following requirements:

- priority may be claimed within six months from the date of filing of the first application;
- a priority may be claimed only from the first filing of a design or a utility model in a country that is a member of the Paris Convention or the World Trade Organization (WTO), or in another State with which there is a reciprocity agreement;
- the proprietor must be the same, or a transfer document establishing the Community design applicant's right to claim the priority of a previous application originally filed by another applicant must be provided;
- the priority declaration (containing date, number and country of the first application) must be submitted not later than one month from the date of filing of the RCD application;
- the details and the certified copy of the previous application must be submitted not later than three months from the date of submission of the declaration of priority.

As a substantive requirement, the Community design must relate to the 'same design or utility model' as the one for which priority is claimed (Article 41(1) CDR). This means that the subject-matter of the previous application must be identical to that of the corresponding Community design, without the addition or suppression of any features. A priority claim is however valid if the Community design and the previous application for a design right or a utility model differ only in immaterial details within the meaning of Article 5 CDR.

When examining an application for a Community design, the Office does not verify whether the application relates to the 'same design or utility model' as the one whose priority is claimed. Therefore, the applicant alone is responsible for ensuring that this requirement is satisfied, failing which the validity of the priority claim could be challenged at a later stage.

A priority claim will be examined for the purposes of Articles 5, 6 and 7 and Article 25(1)(d) CDR by the Office during invalidity proceedings if a third party

challenges the validity of such a priority claim or if the holder challenges the effects of the disclosure of a design, where this disclosure occurred within the priority period (see the Guidelines on the Examination of Design Invalidity Applications, paragraph 5.5.1.8: Disclosure within the priority period).

During the examination phase of an application for a Community design, the Office will limit itself to verifying whether the formalities relating to a priority claim are complied with (Article 45(2)(d) CDR).

Claiming priority

The applicant may claim the priority of one or more previous design or utility model applications. Thus, the priority of more than one previous application can be claimed where two or more Community designs are combined in a multiple application.

If the priority of the same previous application is claimed for all designs of a multiple application, the box 'Same priority for all designs' should be ticked in the (paper) application form.

Any filing that is equivalent to a regular national filing under the domestic law applicable to it will be recognised as giving rise to the right of priority. A regular national filing means any filing that is suitable for establishing the date on which the application was filed in the country concerned, whatever the subsequent outcome of that application (Article 41(3) CDR).

Priority may be claimed either when filing the Community design application or within a period of one month of the filing date. During this one-month period, the applicant must submit the declaration of priority and indicate the date on which and the country in which the previous application was made (Article 8(2) CDIR).

Where there is no indication of the claim in the application, the submission of priority documents within one month of the filing date will be construed as a declaration of priority.

Unless it is expressly indicated in the application that a priority claim will be made subsequently, the application will be examined without delay and, if no deficiency is found, will be registered without waiting one month for any potential declaration of priority. If a declaration of priority is validly filed after registration of the Community design application, a corresponding entry will subsequently be made in the Register.

The applicant must provide the Office with the file number(s) of the previous application(s) and a certified copy of the previous application(s) (Article 8 CDIR) within three months of either the filing date or, as the case may be, receipt of the declaration of priority by the Office.

Deficiencies

The Office will limit itself to verifying whether the formalities relating to a priority claim have been complied with (Article 45(2)(d) CDR), that is,

- whether priority was claimed within six months of filing the first application;

- whether priority was claimed when filing the application or within one month of the filing date;
- whether the details and the copy of the previous application were submitted in due time (within three months of either the filing date or, as the case may be, receipt of the declaration of priority);
- whether the previous application concerns a design or a utility model;
- whether the previous application was filed in a country that is a member of the Paris Convention or the World Trade Organization (WTO), or in another state with which there is a reciprocity agreement;
- whether the previous application was a first filing (meaning that a priority claim should be rejected if the priority application in turn claimed priority);
- whether the proprietor is the same or whether a transfer document establishes the Community design applicant's right to claim the priority of a previous application originally filed by another applicant.

Where remediable deficiencies are found, the examiner will request the applicant to remedy them within two months.

If the deficiencies are not remedied in due time or cannot be remedied, the Office will inform the applicant of the loss of the priority right and of the possibility of requesting a formal (i.e. appealable) decision on that loss (Article 46(1) and (4) CDR; Article 40(2) CDIR).

If the deficiencies that are not remedied concern only some of the designs contained in a multiple application, the right of priority will be lost in respect only of the individual designs concerned (Article 10(8) CDIR).

Whether priority is claimed within six months of filing the first application

The examiner will examine whether the date of filing allocated to the Community design is no later than six months from the filing date of the first application. Applicants should note that the date of **filing** allocated by the Office may not always correspond to the date of **receipt** of the Community design application (see paragraph 3).

In order to speed up registration proceedings, where the date of filing of the Community design application is indisputably and irremediably well beyond this six-month period, the Office will reject the priority claim without formally notifying the applicant of this deficiency.

Where the date of filing of the Community design application is only slightly beyond the six-month period, the examiner will check whether the period has to be extended under one of the conditions provided for in Article 58 CDIR.

The priority right claimed must always be a previous application, which, for this very reason, cannot bear the same date as the Community design application.

Whether priority is claimed when filing the application or within one month of the filing date

The examiner will check that priority has been claimed no later than one month after the filing date of the Community design.

Whether the details of the previous application and the copy of the priority document were submitted in due time

Where priority is claimed when filing or by submitting a declaration of priority, the applicant must indicate the date on which, and the country in or for which the previous application was made (Article 1(1)(f) CDIR). Failure to do so will, however, not lead to an objection: the examiner will wait for the priority document to be submitted.

The file number and the priority document must be submitted within three months of the filing date of the Community design application or submission of the declaration of priority (Article 8 CDIR).

The priority document must consist of a certified copy of the previous application or registration, issued by the authority that received it, and be accompanied by a certificate stating the filing date of that application. The priority document may be filed in the form of an original or as an accurate photocopy. Insofar as the original document contains a representation of the design in colour, the photocopy must also be in colour (Decision No EX-03-05 of the President of the Office of 20/01/2003 concerning the formal requirements of a priority or seniority claim). Applicants claiming the priority of a U.S. patent (design) application are allowed to submit the certified copy of this application in CD-ROM format (Communication No 12/04 of the President of the Office of 20/10/2004).

Where the priority of a previous registered Community design is claimed, the applicant must indicate the number of the previous application and its date of filing. No additional information or document is required (Decision No EX-03-05 of the President of the Office of 20/01/2003 concerning the formal requirements of a priority or seniority claim).

If the language of the previous application is not one of the five Office languages, the examiner may invite the applicant to file a translation within two months (Article 42 CDR). It is not necessary for the whole document to be translated, but only that information allowing the examiner to check the nature of the right (design or utility model), the country of filing, the file number, the filing date and the applicant's name.

In order to speed up registration proceedings, where an examiner detects deficiencies in the priority claim, a deficiency letter will be issued before the time limit expires for submitting all the details of the previous application, including the file number and priority document. The time limit for remedying deficiencies will be no less than three months from the filing date or date of receipt of the declaration of priority.

Whether the previous application concerns a design or a utility model

The priority of a previous design or utility model application may be claimed, including that of a previous Community design or an international design registration.

Many national laws do not provide for the protection of utility models, for example the laws of the United States of America. In the European Union, utility models can be registered in, inter alia, Austria, Czech Republic, Denmark, Finland, Germany, Italy, Hungary, Poland, Portugal, Slovakia and Spain. Utility models can be also be registered in Japan.

A priority claim based on a previous **patent** application will in principle be refused. However, the priority of an international application filed under the Patent Cooperation Treaty (PCT) can be claimed since Article 2 of the PCT defines the term 'patent' in a broad sense that covers utility models.

A priority claim can be based on a previous application filed with the United States Patent and Trademark Office (USPTO) only if the subject-matter of the previous application relates to a 'design patent', not a 'patent'.

Whether the previous application was filed in a country that is member of the Paris Convention or the World Trade Organization (WTO), or in another State with which there is a reciprocity agreement

The states and other territories listed below are not members of any of the relevant conventions, nor do they benefit from reciprocity agreements. Therefore, priority claims based on filings in the following countries and territories will be refused:

Afghanistan (AF)
Abkhazia
American Samoa (AS)
Anguilla (AI)
Aruba (AW)
Bermuda (BM)
Cayman Islands (KY)
Cook Islands (CK)
Eritrea (ER)
Ethiopia (ET)
Falkland Islands (FK)
Guernsey (Channel Islands) (GG)
Isle of Man (IM)
Jersey (Channel Islands) (JE)
Kiribati (KI)
Marshall Islands (MH)
Micronesia (Federated States of) (FM)
Montserrat (MS)
Nauru (NR)
Palau (PW)
Pitcairn (Island) (PN)
Saint Helena (SH)
Somalia (SO)
Turks and Caicos Islands (TC)
Tuvalu (TV)
Virgin Islands, British (VG)

In order to speed up registration proceedings, where the previous application was filed indisputably and irremediably in one of the above countries or territories, the Office will reject the priority claim without formally notifying the applicant of the deficiency.

Whether the previous application is a first filing

As a matter of principle, the previous application must be a first filing. The examiner will therefore check that the priority document does not refer to priority being claimed in respect of an even earlier application.

As an exception, a subsequent application for a design that was the subject of a previous first application and has been filed in or in respect of the same state, will be considered as a first application for the purpose of determining priority, provided that, at the date of filing of the subsequent application, the previous application had been withdrawn, abandoned or refused without being open to public inspection and without leaving any rights outstanding, and had not served as a basis for claiming priority. The previous application may not thereafter serve as a basis for claiming a right of priority (Article 41(4) CDR).

Whether the proprietor is the same or a transfer has occurred

Priority can be claimed by the applicant of the first application or its successor in title. In the latter case, the first application must have been transferred prior to the filing date of the Community design application, and documentation to this effect must be provided.

The right of priority as such may be transferred independently of the first application. Priority can therefore be accepted even if the owners of the Community design and the previous application are different, provided that evidence of assignment of the priority right is supplied. In this case, the execution date of the assignment must be prior to the filing date of the Community design application.

Subsidiary or associated companies of the applicant are not considered to be the same legal entity as the Community design applicant itself.

When, in reply to an objection by the examiner on a discrepancy between the identity of the applicant and that of the previous application holder, the applicant explains that this is due to a corporate name change, a document establishing this change of corporate name must be submitted within two months.

6.2.1.2 Exhibition priority

General principles

The effect of exhibition priority is that the date on which the design was displayed at an officially recognised exhibition is deemed to be the date of filing of the application for a registered Community design for the purposes of Articles 5, 6, 7 and 22, Article 25(1)(d) and Article 50(1) CDR (Article 43 CDR).

The applicant can claim exhibition priority within six months of the first display. Evidence of the display must be filed (Article 44(1) and (2) CDR).

Exhibition priority cannot extend the six-month period of 'Convention priority' (Article 44(3) CDR).

Claiming exhibition priority

Like 'Convention priority' (see paragraph 6.2.1 above), exhibition priority can be claimed either when filing a Community design application or subsequently. Where the applicant wishes to claim exhibition priority after having filed an application, the declaration of priority, indicating the name of the exhibition and the date of first display of the product, must be submitted within a period of one month of the filing date (Article 9(2) CDR).

The applicant must, within three months of the filing date or receipt of the declaration of priority, provide the Office with a certificate issued at the exhibition by the responsible authority. This certificate must state that the design was disclosed at the exhibition, specify the opening date of the exhibition and, where first public use did not coincide with the opening date of the exhibition, the date of first public use. The certificate must be accompanied by identification of the actual disclosure of the product in which the design is incorporated, duly certified by the authority (Article 9(1) and (2) CDR).

Priority can only be granted where the application for a Community design is filed within six months of first display at an exhibition recognised for this purpose, namely a world exhibition within the meaning of the Convention on International Exhibitions signed in Paris on 22/11/1928. These exhibitions are rare and Article 44 CDR does not cover display at other, national or international, exhibitions. The exhibitions can be found on the website of the Paris 'Bureau International des Expositions': <http://www.bie-paris.org/site/en/>.

Deficiencies

The Office will limit itself to verifying whether the formalities relating to an exhibition priority claim have been satisfied (Article 45(2)(d) CDR), that is,

- whether the filing date of the Community design falls within the six-month period following the first display of the product;
- whether priority was claimed when filing the application or within one month of the filing date;
- whether the application or the subsequent declaration of priority gives details of the name of the exhibition and the date of first display of the product;
- whether the exhibition was a world exhibition within the meaning of the Convention on International Exhibitions of 22/11/1928;
- whether the certificate issued at the exhibition by the responsible authority was submitted in due time;
- whether the proprietor named in this certificate is the same as the applicant.

Where remediable deficiencies are found, the examiner will request the applicant to remedy them within a time limit no shorter than the three-month time limit for submitting the certificate referred to above.

If the deficiencies are not remediable or are not remedied in due time, the Office will inform the applicant of the loss of the priority right and of the possibility of requesting a formal (i.e. appealable) decision on that loss (Article 46(1) and (4) CDR; Article 40(2) CDR).

If the deficiency concerns only some of the designs contained in a multiple application, the right of priority shall be lost in respect only of the individual designs concerned (Article 10(8) CDIR).

6.2.2 Description

The application may include a description not exceeding 100 words explaining the representation of the design or the specimen (see paragraph 3.3.5 above). The description must relate only to those features that appear in the reproductions of the design or the specimen. It may not contain statements concerning the purported novelty or individual character of the design or its technical value (Article 1(2)(a) CDIR).

The description does not affect the scope of protection of a Community design as such (Article 36(6) CDR).

The description may, however, clarify the nature or purpose of some features of the design in order to overcome a possible objection. For instance, where different views of the same design display different colours, thus raising doubts as to consistency between them (see paragraph 5.2.5 above), the description may explain that the colours of the design change when the product in which this design is incorporated is in use.

Descriptions submitted after the date of filing of the application will not be accepted.

The Register will include a mention that a description has been filed, but the description as such will not be published. The description, however, will remain part of the administrative file of the application and will be open to public inspection by third parties under the conditions set out at Article 74 CDR and Articles 74 and 75 CDIR.

6.2.3 Indication of the Locarno Classification

6.2.3.1 General principles

The applicant may itself identify the classification, in accordance with the Locarno Classification, of the products indicated in the application (see paragraph 6.1.4 above).

If the applicant provides a classification, the products must be grouped in accordance with the classes of the Locarno Classification, each group being preceded by the number of the relevant class, and presented in the order of the classes and subclasses (Article 3 CDIR).

Since classification is optional, no objection will be raised if the applicant does not submit a classification or does not group or sort the products as required, provided that no objection is raised with regard to the indication of products (paragraph 4.6 above). If no such objection is raised, the examiner will classify the products *ex officio* according to the Locarno Classification.

Where the applicant has indicated only the main class and no subclass, the examiner will assign the subclass that appears suitable in view of the design shown in the representation. For instance, where a design application indicates *packaging* in Class 9 of the Locarno Classification, and the design represents a bottle, the examiner will

assign subclass 09-01 (the heading of which is *Bottles, flasks, pots, carboys, demijohns, and containers with dynamic dispensing means*).

Where the applicant has given the wrong classification, the examiner will assign the correct one *ex officio*.

Products that combine different elements so as to perform more than one function may be classified in as many classes and subclasses as the number of purposes served. For instance, the product indication *Refrigerating boxes with radios and CD players* will be classified under Classes 14-01 (*Equipment for the recording or reproduction of sounds or pictures*), 14-03 (*Communications equipment, wireless remote controls and radio amplifiers*) and 15-07 (*Refrigeration machinery and apparatus*) of the Locarno Classification.

6.2.3.2 Multiple application and the requirement of 'unity of class'

If the same product indication applies to all designs contained in a multiple application, the relevant box 'Same indication of product for all designs' should be ticked in the (paper) application form and the field 'Indication of product' left blank for the subsequent designs.

Where several designs other than ornamentation are combined in a multiple application, the application will be divided if the products in which the designs are intended to be incorporated or to which they are intended to be applied belong to more than one class of the Locarno Classification (Article 37(1) CDR; Article 2(2) CDIR; see paragraph 7.2.3).

6.2.4 Citation of the designer(s)

The application may include

- (a) a citation of the designer(s), or
- (b) a collective designation for a team of designers, or
- (c) an indication that the designer(s) or team of designers has/have waived the right to be cited (Article 18 CDR; Article 1(2)(d) CDIR).

The citation, the waiver and an indication regarding the designer(s) are merely optional and are not subject to examination.

If the designer or the team of designers is the same for all designs applied for in a multiple application, this should be indicated by ticking the box 'Same designer for all designs' in the (paper) application form.

Since the right to be cited as the designer is not limited in time, the designer's name can also be entered into the Register after registration of the design (Article 69(2)(j) CDIR).

6.2.5 Request for deferment

6.2.5.1 General principles

The applicant for a registered Community design may, when filing the application, request that its publication be deferred for **30 months** from the date of filing or, if a priority is claimed, from the date of priority (Article 50(1) CDR).

Where no deficiency is found, the Community design will be registered. The information published in Part A.2. of the Community Designs Bulletin consists of the file number, date of filing, date of entry in the Register, registration number, name and address of the holder and name and business address of the representative (if applicable). No other particulars such as the representation of the design or the indication of products are published (Article 14(3) CDR).

Nevertheless, third parties may inspect the entire file if they have obtained the applicant's prior approval or if they can establish a legitimate interest (Article 74(1) and (2) CDR).

In particular, there is a legitimate interest where an interested person submits evidence that the holder of the registered Community design whose publication is deferred has taken steps with a view to invoking the right against them.

No registration certificate will be made available as long as the publication of a design is deferred. The holder of the design registration subject to deferment may, however, request a certified or uncertified extract of the registration, containing the representation of the design or other particulars identifying its appearance (Article 73(b) CDR), for the purpose of invoking its rights against third parties (Article 50(6) CDR).

The procedure described in this Section does **not** apply to international registrations designating the European Union (see paragraph 12 below).

6.2.5.2 Request for deferment

Deferment of publication must be requested in the application (Article 50(1) CDR). Subsequent requests will not be accepted, even if received on the same day.

Applicants should be aware that designs can be registered and accepted for publication within two working days and even sometimes on the day that the application is received (see paragraph 2.7.1 above). If, by mistake, an application does not contain a request for deferment, the application should be withdrawn in order to prevent publication. Given the speed of the registration and publication processes, this should be done *immediately* after filing. The applicant should also contact an examiner on the day of the withdrawal.

A request for deferment of publication may concern only some of the designs of a multiple application. In this case, the designs to be deferred must be clearly identified by ticking the box 'Request for deferment of publication' on the (paper) form or the box 'Publication to be deferred' (e-filing) for each individual design.

The applicant must pay a fee for deferment of publication along with the registration fee (see paragraph 8 below). Payment of the publication fee is optional at the filing stage.

6.2.5.3 Request for publication

When applying, or at the latest three months before the 30-month period expires (that is, on the last day of the 27th month following the filing date or priority date, as the case may be), the applicant must comply with what are known as the ‘publication request requirements’ (Article 15 CDIR), by:

- paying the publication fee for the design(s) to be deferred (see paragraph 8);
- in cases where a representation of the design has been replaced by a specimen in accordance with Article 5 CDIR (see paragraph 3.3.5 above), filing a representation of the design in accordance with Article 4 CDIR (see paragraph 5);
- in the case of a multiple registration, clearly indicating which of the designs among those identified for deferment are to be published or surrendered, or for which designs deferment is to be continued, as the case may be.

Where the Community design holder notifies the Office, **any time before the 27 months have expired**, of its wish to have the design(s) published (‘request for anticipated publication’), it must specify whether publication should take place as soon as technically possible (Article 16(1) CDIR) or when the 30-month deferment period expires. Where there is no specific request from the applicant, the designs will be published when the deferment period expires.

If the holder, despite a previous request for publication, decides that the design should not be published after all, it must submit a written request for surrender well before the design is due to be published. Any publication fees already paid will not be refunded.

6.2.5.4 Observation of time limits

Community design holders should be aware that the Office will not issue reminders regarding the expiry of the 27-month period before which the publication request requirements must be complied with. It is therefore the responsibility of the applicant (or, as the case may be, its representative) to make sure that the time limits are observed.

Particular attention must be paid where a priority date was claimed either at the time of or after filing, since this priority date will determine the time limits applicable to deferment. Moreover, the time limits applicable to deferment may differ for each of the designs of a multiple registration, if different priority dates are claimed for each individual design.

Where the time limit for complying with ‘the publication request requirements’ is not met, thus resulting in a loss of rights, the Community design holder may file a request for *restitutio in integrum* (Article 67 CDR; See also the Guidelines Concerning Proceedings before the Office for Harmonization in the Internal Market (Trade Marks and Designs), Part A, Section 8, *Restitutio in integrum*).

6.2.5.5 Deficiencies

Deficiencies at the examination stage

If the information contained in the application is contradictory (e.g. the deferment fee has been paid, but the applicant has not ticked the box 'Request for deferment of publication') or inconsistent (e.g. the amount of the deferment fees paid for a multiple application does not correspond to the number of designs to be deferred), the examiner will issue a deficiency letter asking the applicant to confirm that deferment is requested and, where applicable, for which specific design(s) of a multiple application, and/or to pay the corresponding fees.

Deficiencies relating to the 'publication request requirements'

If, once the 27-month period following the filing date or priority date of the Community design registration has expired, the holder has failed to comply with the 'publication request requirements', the examiner will issue a deficiency letter giving two months for the deficiencies to be remedied (Article 15(2) CDIR).

Where a deficiency concerns the payment of publication fees, the applicant will be requested to pay the correct amount plus fees for late payment (that is, EUR 30 for a design and, in the case of a multiple application, 25% of the fees for publication for each additional design; Article 15(4) CDIR; Articles 8 and 10 of the Annex to the CDFR).

Applicants should be aware that the time limit set by the examiner cannot be extended beyond the 30-month period of deferment (Article 15(2) CDIR).

If deficiencies are not remedied within the set time limit, the registered Community design(s) to be deferred will be deemed from the outset not to have had the effects specified in the CDR (Article 15(3)(a) CDIR).

The examiner will notify the holder accordingly, after the 30-month period of deferment has expired.

In the case of a 'request for anticipated publication' (see paragraph 6.2.5.3), failure to comply with the publication request requirements will result in the request being deemed not to have been filed (Article 15(3)(b) CDIR). The publication fee will be refunded if it has already been paid. Where there are still more than 3 months before the 27-month period expires, the holder may, however, submit another request for publication.

Where the deficiency concerns a payment that is insufficient to cover the publication fees for all the designs that are to be deferred in a multiple application, including any fees for late payment, the designs not covered by the amount paid will be deemed from the outset not to have had the effects specified in the CDR. Unless the holder made it clear which designs were to be covered by the amount paid, the examiner will take the designs in consecutive numerical order (Article 15(4) CDIR).

Publication after deferment

Where there are no deficiencies or deficiencies have been overcome in due time, the registration will be published in Part A.1 of the Community Designs Bulletin.

The holder may request that only some of the designs of a multiple application are published.

Mention will be made in the publication of the fact that deferment was originally applied for and, where applicable, that a specimen was initially filed (Article 16 CDR).

7 Multiple Applications

7.1 General principles

A multiple application is a request for the registration of more than one design within the same application. Each of the designs contained in a multiple application or registration is examined and dealt with separately. In particular, each design may, separately, be enforced, be licensed, be the subject of a right *in rem*, a levy of execution or insolvency proceedings, be surrendered, renewed or assigned, be the subject of deferred publication or be declared invalid (Article 37(4) CDR).

Multiple applications are subject to specific registration and publication fees, which decrease in proportion to the number of designs (see paragraph 8 below).

7.2 Formal requirements applying to multiple applications

7.2.1 General requirements

All the designs in a multiple application must have the same owner(s) and the same representative(s) (if any).

The number of designs contained in a multiple application is unlimited. The designs need not be related to one another or be otherwise similar in terms of appearance, nature or purpose.

The number of designs should not be confused with the 'number of views' that represent the designs (see paragraph 5.1 above).

Applicants must number the designs contained in a multiple application consecutively, using Arabic numerals (Article 2(4) CDR).

A suitable representation of each design contained in a multiple application must be provided (see paragraph 5 above) and an indication given of the product in which the design is intended to be incorporated or to be applied (Article 2(3) CDR, see paragraph 6.1.4 above).

7.2.2 Separate examination

Each of the designs contained in a multiple application is examined separately. If a deficiency concerning some of the designs contained in a multiple application is not remedied within the time limit set by the Office, the application will be refused only in so far as those designs are concerned (Article 10(8) CDIR).

The decisions on the registration or refusal of the designs contained in a multiple application will all be taken at the same time.

Even if some of the designs in a multiple application already comply with both the substantive and formal requirements, they will not be registered until any deficiencies affecting other designs have been remedied or the designs in question have been refused by the decision of an examiner.

7.2.3 The 'unity of class' requirement

7.2.3.1 Principle

As a rule, all the product(s) indicated for the designs contained in a multiple application must be classified in only one of the 32 Locarno classes.

As an exception, the indication *Ornamentation* or *Product(s) X (Ornamentation for -)* in Class 32-00 can be combined with indications of products belonging to another Locarno class.

7.2.3.2 Products other than ornamentation

The products indicated for each design in a multiple application may differ from those indicated for others.

However, except in cases of *ornamentation* (see paragraph 7.2.3.3 below), any products that are indicated for each and every design of a multiple application must belong to the same class of the Locarno Classification (Article 37(1) CDR; Article 2(2) CDIR). This 'unity of class' requirement is considered to be complied with even if the products belong to different subclasses of the same class of the Locarno Classification.

For instance, a multiple application is acceptable if it contains one design with the product indication *Motor vehicles* (Class 12, subclass 08) and one design with the product indication *Vehicle interiors* (Class 12, subclass 16), or if both designs indicate both these terms. This is an example of two designs in different subclasses but in the same class, namely Class 12 of the Locarno Classification.

An objection would, however, be raised if, in the above example, the products indicated were *Motor vehicles* (Class 12, subclass 08) and *Lights for vehicles*, since the second term belongs to Class 26, subclass 06 of the Locarno Classification. The examiner would then require the multiple application to be divided, as explained under paragraph 7.2.3.4 below.

A multiple application cannot be divided unless there is a deficiency affecting the 'unity of class' requirement (Article 37(4) CDR).

7.2.3.3 Ornamentation

Ornamentation is a decorative element capable of being applied to the surface of a variety of products without affecting their contours. It can be a two-dimensional pattern or a three-dimensional moulding or carving, in which the design stands out from a flat surface.

Although ornamentation is, in itself, a product within the meaning of the Locarno Classification (Class 32), its primary purpose is to constitute one of the features of other products.

A multiple application can therefore combine designs for ornamentation with designs for products such as those to which this ornamentation will be applied, provided that all the products belong to the same class of the Locarno Classification.

For some designs, the indication *Ornamentation* or *Product(s) X (Ornamentation for)* in Class 32 of the Locarno Classification is neutral and therefore ignored for the purpose of examining whether the product indication for the remaining designs meets the 'unity of class' requirement.

The same reasoning applies to the following product indications in Class 32 of the Locarno Classification: *Graphic symbols, Logos* and *Surface patterns*.

For example, a multiple application is acceptable if it combines designs for *Ornamentation* or *China (Ornamentation for)* in Class 32 with designs representing pieces of a tea set for *China* in Class 7, subclass 01. In turn, if *Linen (Table -)* were indicated as a product for one of these designs, an objection would be raised as this product belongs in Class 6, subclass 13 of the Locarno Classification, that is, a different class.

Where the applicant has indicated the product as *Ornamentation* or *Product(s) X (Ornamentation for)*, the examiner will prima facie examine whether it is really for ornamentation by looking at the design in question. Where the examiner agrees that it is for ornamentation, the product will be classified in Class 32.

Where the examiner does not agree that the design is for ornamentation, a deficiency letter must be sent on the grounds of an obvious mismatch between the products indicated and the design (see paragraph 6.1.6.3 above).

Where the representation of the design is not limited to ornamentation itself but also discloses the product to which such ornamentation is applied, without the contours of this product being disclaimed, this specific product must be added to the list of products and the classification must be amended accordingly (see paragraph 6.1.4.4).

This may lead to an objection where a multiple application combines a number of such designs applied to products that belong to different classes of the Locarno Classification.

7.2.3.4 Deficiencies

For example, let us assume that three designs representing cars are combined in one multiple application, and the product indication for each design is *Motor cars* (subclass 12-08) and *Scale models* (subclass 21-01).

The examiner will issue an objection and request the applicant to:

- delete some of the product indications so that the remaining products can be classified in only one Locarno class; or
- divide the application into two multiple applications for each of the Locarno classes concerned, and pay the corresponding additional fees; or
- divide the application into three single applications for each design concerned, and pay the corresponding additional fees.

In some cases, it will not be possible to delete product indications, for example where a given product must be classified in two or more classes on account of the plurality of purposes it serves (see paragraph 6.2.3.1).

The applicant will be invited to comply with the examiner's request within two months and pay the total amount of fees for all applications resulting from the division of the multiple application or to delete some products in order to meet the 'unity of class' requirement.

The total amount to be paid is calculated by the examiner and notified to the applicant in the examination report. The examiner proposes the most cost-effective option between dividing the multiple application into as many applications as Locarno classes concerned or as many applications as designs concerned.

Where the applicant does not remedy the deficiencies in due time, the multiple application is refused **in its entirety**.

8 Payment of Fees

8.1 General principles

Community design applications are subject to various fees, which the applicant must pay **at the time of filing** (Article 6(1) CDIR), including the registration fee and the publication fee or, where the application includes a request for deferment of the publication, the deferment fee.

In the case of multiple applications, additional registration, publication or deferment fees must be paid for each additional design. If payment has not been made when filing the application, late payment fees must also be paid.

In the case of deferment, applicants can, when filing, choose to pay not only the registration and deferment fee, but also the publication fee.

For the fee payable with respect to an international application designating the European Union see paragraph 12.1.2.3 Fee.

8.2 Currency and amounts

Fees must be paid in euros. Payments made in other currencies are not accepted.

The fees for filing an application are as follows:

Registration fees

Single design or first design in a multiple application	€230
2nd to 10th design in a multiple application	€115 per design
11 th + design in a multiple application	€50 per design

Publication fees

Single design or first design to be published in a multiple application	€120
2nd to 10th design to be published in a multiple application	€60 per design
11th+ design to be published in a multiple application	€30 per design

Deferment fees (where deferment of publication is requested)

Single design or first design with deferment of publication in a multiple application	€40
2nd to 10th design with deferment of publication in a multiple application	€20 per design
11th+ design with deferment of publication in a multiple application	€10 per design

Example of fees due for the filing of a multiple application where the publication of only some designs is to be deferred

Design number	deferment	Registration fee	Publication fee	Deferment fee
xxxxxxx-0001	Yes	€230	-	€40
xxxxxxx-0002	Yes	€115	-	€20
xxxxxxx-0003	No	€115	€120	-
xxxxxxx-0004	No	€115	€60	-
xxxxxxx-0005	No	€115	€60	-

If, after registration, publication is requested for design xxxxxxx-0001, this will in effect be the fourth design to be published and the publication fee will be EUR 60.

8.3 Means of payment, details of the payment and refund

The means of payment, the details to accompany the payment and the conditions for a refund of fees paid are explained in the Guidelines for examination on Community trade marks, Part A, General rules, Section 3, Payment of fees, costs and charges.

Fees are refunded when the application is withdrawn or refused without a filing date having been granted (application 'not dealt with as a Community design application')

The Office also refunds amounts paid that are insufficient to cover the registration and publication (or deferment) fees for the design or at least one design of a multiple application.

9 Withdrawals and Corrections

9.1 Introduction

The applicant may at any time during the examination withdraw an application for a registered Community design or, in the case of a multiple application, withdraw some of the designs contained in the multiple application. Corrections are allowed only in some specific situations.

Any correction or change to the Register and/or publication, that is after the design has been registered by the examiner, must be dealt with in accordance with paragraph 11 below.

9.2 Withdrawal of the application

Prior to registration the applicant may at any time withdraw an application for a Community design or, in the case of a multiple application, withdraw some of the designs contained in the multiple application (Article 12(1) CDIR). The examiner will send confirmation of the withdrawal.

Requests for withdrawal must be submitted in writing and include:

- the file number of the application for a registered Community design or, where the request for withdrawal is submitted before an application number has been allocated, any information enabling the application to be identified, such as the reference number of the applicant / representative and / or the provisional file number referred to in the automatic receipt for applications filed via the e-filing system;
- in the case of a multiple application, an indication of the design(s) that the applicant wants to withdraw if only some are to be withdrawn; and
- the name and address of the applicant and / or, if applicable, the name and address of the representative.

The 'date of withdrawal' is the date on which the Office receives the request for withdrawal.

Fees will not be refunded if a filing date has been granted, except where the amount of fees paid by the applicant is insufficient to cover the fees relating to registration and publication (or deferment as the case may be) for the design, or for at least one design of a multiple application.

Requests for withdrawal received by the Office on or after the date of registration of the design will be dealt with as requests for surrender.

Requests for withdrawal received by the Office on the filing date of the design application will be accepted even if the design is registered that same day.

9.3 Corrections to the application

9.3.1 Elements subject to correction

Only the name and address of the applicant or the representative, errors of wording or of copying, or obvious mistakes may be corrected, at the request of the applicant (Article 12(2) CDIR).

Apart from the name and address of the applicant or representative, the following elements may be corrected at the applicant's request if they contain errors of wording or of copying or obvious mistakes:

- the date of filing, where the application was filed with the central industrial property office of a Member State or, in Benelux countries, with the Benelux Office for Intellectual Property (BOIP), upon notification by the office concerned that an error regarding the date of receipt has been made;
- the name of the designer or team of designers;
- the second language;
- an indication of the product(s);
- the Locarno classification of the product(s) contained in the application;
- the country, date and number of the prior application where Convention priority is claimed;
- the name, place and date of the first exhibition of the design where exhibition priority is claimed;
- the description.

9.3.2 Elements that cannot be corrected

As a matter of principle, the representation of the design(s) cannot be altered after the application has been filed (Article 12(2) CDIR). The submission of additional views or the withdrawal of any views at a later stage will not be accepted, unless expressly required or proposed by the Office (see paragraphs 5.2 and 5.5 above).

Where a request for correction amends the representation of the design(s), the applicant will be informed that its request is not acceptable. The applicant must decide whether it wishes to continue the registration process or to file a fresh application for which it will have to pay the applicable fees.

9.3.3 Procedure for requesting correction

A request for correction of the application must contain:

- a) the file number of the application;
- b) the name and address of the applicant;
- c) where the applicant has appointed a representative, the name and business address of the representative;
- d) an indication of the element of the application to be corrected and the corrected version of that.

A single request may be made for correction of the same element in two or more applications belonging to the same applicant.

If all the requirements are met, the examiner will send confirmation of the correction.

Corrections and amendments after registration are dealt with by the Operations Support Department (see paragraph 11 below).

9.3.4 Deficiencies

Where a request for correction does not meet the above requirements and the deficiency found can be remedied, the examiner will invite the applicant to remedy the deficiency within two months. If the deficiency is not remedied in due time, the examiner will refuse the request for correction.

Requests for correction that would have the effect of amending the representation of the design(s) will be refused irremediably.

Descriptions submitted after the date of filing of the application are not accepted (see paragraph 6.2.2 above). Requests for correction that involve submitting a description after the date of filing of the application will therefore be refused.

10 Registration, Publication and Certificates

10.1 Registration

Once examination of absolute grounds for refusal and formalities is completed, the examiner must ensure that all the particulars referred to in Article 14 CDR have been provided (particulars which are mandatory for the applicant and which must be indicated in the application are highlighted):

- (a) the filing date of the application;
- (b) the file number of the application and of each individual design included in a multiple application;
- (c) the date of publication of the registration;
- (d) **the name, address and nationality of the applicant and the state in which it is domiciled or has its seat or establishment;**
- (e) **the name and business address of the representative**, other than an employee acting as representative in accordance with the first sentence of Article 77(3) CDR; where there is more than one representative, only the name and business address of the first-named representative, followed by the words 'et al', will be recorded; where an association of representatives is appointed, only the name and address of the association will be recorded;
- (f) **the representation of the design;**
- (g) **an indication of the product(s)** by name, preceded by the number(s) of and grouped according to the class(es) and subclass(es) of the Locarno Classification;
- (h) particulars of priority claims pursuant to Article 42 CDR;
- (i) particulars of exhibition priority claims pursuant to Article 44 CDR;
- (j) the citation of the designer or team of designers or a statement that the designer or team of designers has waived the right to be cited;

- (k) **the language in which the application was filed and the second language** indicated by the applicant pursuant to Article 98(2) CDR;
- (l) the date of registration of the design in the Register and the registration number;
- (m) a mention of any request for deferment of publication pursuant to Article 50(3) CDR, specifying the date of expiry of the period of deferment;
- (n) a mention that a specimen has been filed pursuant to Article 5 CDIR;
- (o) a mention that a description was filed pursuant to Article 1(2)(a) CDIR;
- (p) a mention that the representation of the design contains a verbal element.

Once all the particulars in the check-list are on file, the examiner will check whether all the applicable fees have been paid.

Where no deficiency is found, the application is registered.

10.2 Publication

10.2.1 General principles

All registered Community designs are published in the Community Designs Bulletin, which is published in electronic format only, on the OHIM website.

However, international registrations designating the European Union are published by WIPO (Hague Express Bulletin) (see paragraph 12 below).

Unless an application contains a request for deferment of publication, publication will take place immediately after registration; publication is daily.

Where an application contains a request for deferment of publication, publication is made in Part A.2 of the Bulletin and is limited to the following particulars: the design number, filing date, registration date and the names of the applicant and the representative, if any.

Where an application contains a request for deferment of publication for only some of the designs of a multiple application, only the designs for which deferment has not been requested are published in full.

10.2.2 Format and structure of the publication

The Community Designs Bulletin is available in two formats:

- HTML
- PDF.

Both formats are equally valid for publication and search purposes.

The Community Designs Bulletin comprises the following four parts:

- **Part A** deals with Community design registrations and consists of three sections:
 - Part A.1: Community design registrations in accordance with Articles 48 and 50 CDR.

- Part A.2: Community design registrations with requests for deferment and their first publication in accordance with Article 50 CDR and Article 14(3) CDIR.
- Part A.3: Errors in Part A (mistakes and errors in registrations). A.3.1: absolute errors; A.3.2: relative errors.
- **Part B** deals with entries in the Register subsequent to registration, such as amendments, transfers, licences, etc. and consists of eight sections:
 - Part B.1: mistakes and errors
 - Part B.2: transfers
 - Part B.3: invalidity and entitlement proceedings
 - Part B.4: surrenders and designs without effects
 - Part B.5: licences
 - Part B.6: rights *in rem*
 - Part B.7: insolvency proceedings
 - Part B.8: levy of execution (seizures).
- **Part C** deals with renewals and information on expired registrations and is subdivided into three sections:
 - Part C.1: Renewals in accordance with Article 13(4) CDR and Article 69(3)(m) CDIR.
 - Part C.2: Expired registrations according to Articles 22(5) and 69(3)(n) CDIR.
 - Part C.3: Correction of errors or mistakes in renewals and expired registrations.
- **Part D** deals with *Restitutio in integrum* (Article 67 CDR) and is divided into two sections:
 - Part D.1: *Restitutio in integrum*.
 - Part D.2: Correction of errors or mistakes in Part D.

In the Bulletin, each item is preceded by the corresponding **INID code** in accordance with WIPO standard ST.80. Where appropriate, information is published in all official EU languages (Article 70(4) CDIR).

The **INID codes** used for items published in for example Part A.1 of the Bulletin are as follows:

- 21 File number
- 25 Language of filing and second language
- 22 Date of filing
- 15 Date of entry into the Register
- 45 Date of publication
- 11 Registration number
- 46 Date of expiry of the deferment
- 72 Name(s) of designer(s) or team of designers
- 73 Name and address of the holder
- 74 Name and business address of the representative
- 51 Locarno classification
- 54 Indication of the product(s)

- 30 Country, date and number of application for which priority is claimed (Convention priority)
- 23 Name, place and date on which the design was first exhibited (exhibition priority)
- 29 Indication that a specimen was filed
- 57 Indication that a description was filed
- 55 Representation of the design

The publication is made in all EU languages that are official on the date of the application.

10.3 Registration certificate

A registration certificate is issued after the registered Community design has been published in full (i.e. publication in Part A.1).

However, the Office does not issue registration certificates for international registrations designating the European Union (see paragraph 12 below).

Since 15/11/2010, registration certificates have been issued only as online e-certificates. Holders of Community design registrations are invited to download the certificate from the day after publication, using the “eSearch plus” tool on the OHIM website. . No paper copy of the certificate of registration will be issued. However, certified or uncertified copies of the registration certificate may be requested.

The certificate contains all the particulars entered in the Community designs Register at the date of registration. No new certificate is issued following changes made in the Register after the date of registration. However, an extract from the Register, which reflects the current administrative status of the design(s), may be requested.

A corrected certificate is issued after publication of a relative error detected in a design registration (Part A.3.2) or after publication of a relative error detected in a recordal (Part B.1.2). A relative error is an error attributable to the Office that modifies the scope of the registration.

11 Corrections and Changes in the Register and in the Publication of Community Design Registrations

11.1 Corrections

11.1.1 General Principles

Only the name and address of the applicant, errors of wording or of copying, or obvious mistakes may be corrected, at the request of the applicant and provided that such correction does not change the representation of the design (Article 12(2) CDIR) (decision of 3/12/2013, R 1332/2013-3 ‘Adapters’, para. 14 et seq.). There is no fee for such requests.

Where the registration of a design or the publication of the registration contains a mistake or error attributable to the Office, the Office will correct the error or mistake of its own motion or at the request of the holder (Article 20 CDIR). There is no fee for such requests.

A request for correction of mistakes made by the Office can only refer to the contents of the publication of the registration (Articles 49, 73 and 99 CDR and Articles 14 and 70 CDIR) and the entries in the Register (Articles 48, 72 and 99 CDR and Articles 13 and 69 CDIR).

Unless the Office itself made an error when publishing the representation of the design(s) (e.g. by distorting or truncating the representation), the holder will not be allowed to request the correction of its Community design if this has the effect of altering the representation (Article 12(2) CDIR) (decision of 3/12/2013, R 1332/2013-3 'Adapters', para. 14 et seq.).

Corrections will be made as soon as the mistake is detected, including, where necessary, years after the original entry in the Register.

11.1.2 The request for correction

According to Articles 12 and 19 CDIR, requests for the correction of mistakes and errors in the Register and in the publication of the registration must contain:

- a) the registration number of the registered Community design;
- b) the name and address of the holder as registered in the Register or the name of the holder and the identification number assigned to the holder by the Office;
- c) where the holder has appointed a representative, the name and business address of the representative or the name of the representative and the identification number assigned to the representative by the Office; and
- d) an indication of the entry in the Register and/or of the content of the publication of the registration to be corrected and the corrected version of the element in question.

A single request may be made for the correction of errors and mistakes in respect of two or more registrations belonging to the same holder (Article 19(4) and Article 20 CDIR).

If the requirements for such corrections are not fulfilled, the Office will inform the applicant of the deficiency. If the deficiency is not remedied within the two months specified by the Office, the request for correction will be refused (Article 19(5) and 20 CDIR).

Requests for the correction of mistakes or errors that are not entries in the Register and / or that do not concern the contents of the publication of registrations will be refused. Accordingly, requests for correction of the description explaining the representation of the design or the specimen will be refused.

Errors in the translation of the product indication into the official EU languages are considered attributable to the Office and will be corrected because the translations are considered as entries in the Register and as part of the contents of the publication of the registration, despite the fact that the translations are done not by the Office but by the Translation Centre for the Bodies of the European Union (Communication No 4/05 of the President of the Office of 14/06/2005 concerning the correction of mistakes and errors in the Register and in the publication of the registration of Community designs).

In cases of doubt, the text in the Office language in which the application for a registered Community design was filed will be authentic (Article 99(3) CDR). If the application was filed in an official EU language other than one of the Office languages, the text in the second language indicated by the applicant will be authentic.

11.1.3 Publication of corrections

The holder will be notified of any changes in the Register (Article 69(5) CDIR).

Corrections will be published by the Office in Part A.3 of the Community Designs Bulletin and entered in the Register together with the date on which they were recorded (Article 20 and 69(3)(e) CDIR).

Where the mistake or error is attributable to the Office, the Office will, after publication of the mistake or error, issue the holder with a certificate of registration containing the entries in the Register (Article 69(2) CDIR) and a statement to the effect that those entries have been recorded in the Register (Article 17 CDIR).

In cases where the mistake or error is the holder's, a certificate of registration reflecting the corrected mistake or error will be issued only where no certificate has previously been issued. In any event, holders can always request the Office to issue an extract of the Register (in certified or simple form) to reflect the current status of their design(s).

11.2 Changes in the Register

11.2.1 Introduction

This section describes the changes in the Community designs Register, as follows:

- surrender of a Community design with or without deferment, in particular partial surrender;
- changes in the name and address of the applicant and / or of the representative, where applicable, of which the Office was notified before registration of the Community design (i.e., before issue of the notification of registration);
- changes in the name and address of the holder and / or of the representative, where applicable, for a Community design with deferred publication that has not been published yet;
- recordal of transfers;
- recordal of licences.

11.2.2 Surrender of the registered Community design

11.2.2.1 General principles

A Community design may be surrendered by the holder at any time after registration. A surrender must be declared to the Office in writing (Article 51 CDR).

However, a request for renunciation of an international design designating the European Union must be filed with, and recorded by, the International Bureau (see Article 16 of the Geneva Act and paragraph 12.2.2.5 below).

Surrender can also be declared for only some of the designs contained in a multiple registration (Article 27(1)(d) CDIR).

The effect of a declaration of surrender begins on the date on which the surrender is entered in the Community designs Register, without any retroactive effect (Article 51(1) CDR). However, if a Community design for which publication has been deferred is surrendered, it will be deemed from the outset not to have had the effects specified in the CDR (Article 51(2) CDR).

A registered Community design may be partially surrendered provided that its amended form complies with the requirements for protection and the identity of the design is retained (Article 51(3) CDR). Partial surrender will therefore be limited to cases in which the features removed or disclaimed do not contribute to the novelty or individual character of a Community design, in particular:

- where the Community design is incorporated in a product that constitutes a component part of a complex product, and the removed or disclaimed features are invisible during normal use of this complex product (Article 4(2) CDR); or
- where the removed or disclaimed features are dictated by a function or by interconnection purposes (Article 8(1) and (2) CDR); or
- where the removed or disclaimed features are so insignificant in view of their size or importance that they are likely to go unnoticed by the informed user.

The surrender will be entered in the Register only with the agreement of the proprietor of a right entered in the Register (Article 51(4) CDR). Persons having a registered right include the holders of a registered licence, the proprietors of a registered right *in rem*, the creditors of a registered levy of execution or the authority competent for the registered bankruptcy or similar procedures.

In the case of licences registered in the Community design Register, the surrender of a Community design is entered in the Register only upon receipt of evidence that the right holder has informed licensee(s) of the surrender accordingly. The surrender is entered in the Register three months after the date on which the Office obtains proof that the holder has informed licensee(s) of the surrender accordingly or earlier if proof is obtained of the licensee's(licensees') consent to the surrender (Article 51(4) CDR; Article 27(2) CDIR).

Where a claim relating to the entitlement to a registered Community design has been brought before a court pursuant to Article 15 CDR, the surrender is entered in the Register only with the agreement of the claimant (Article 27(3) CDIR).

11.2.2.2 Formal requirements for a declaration of surrender

A declaration of surrender must contain the particulars referred to in Article 27(1) CDIR:

- a) registration number of the registered Community design;
- b) name and address of the holder;
- c) name and address of the representative, where appointed;
- d) indication of the designs for which the surrender is declared in the case of multiple registrations;
- e) representation of the amended design in accordance with Article 4 CDIR in the case of partial surrender.

In the case of a partial surrender, the holder must submit a representation of the Community design as amended (Article 27(1)(e) CDIR).

If a declaration of surrender does not contain all the particulars listed above and does not fulfill all the above requirements, depending on the situation, the Office will notify the holder of the deficiencies and request that they be remedied within the prescribed time limit. Where the deficiencies are not remedied within the time limit, the surrender will not be entered in the Register and the Community design holder will be informed thereof in writing (Article 27(4) CDIR).

11.2.3 Changes in the name and address of the applicant / holder and / or its representative

The Community design holder may request recordal of the change of name or address in the Register by submitting a written request to the Office. Recordals of changes of name and / or address are free of charge.

The request for recordal of a change of name or address in respect of an international design designating the European Union must be filed with the International Bureau (see Article 16 of the Geneva Act).

For the differences between a change of name and a transfer, see the Guidelines on Community Trade Marks, Part E, Section 3, Chapter 1, on 'Transfers and changes of name'.

A single request may be made for a change of name or address in respect of two or more registrations belonging to the same holder.

A request for a change of name or address by a Community design holder must contain:

- a) the registration number of the Community design;
- b) the holder's name and address as recorded in the Register or the holder's identification number;
- c) an indication of the holder's name and address as changed;
- d) the name and address of the representative, where appointed.

If the above requirements are not fulfilled, the Office will send a deficiency letter. If the deficiency is not remedied within the specified time limit, the Office will refuse the request (Article 19(5) CDIR).

Changes of name and address for Community design applicants in connection with applications for Community designs are not entered in the Register but must be recorded in the files kept by the Office concerning Community design applications (Article 19(7) CDIR).

Changes in the holders of Community design registrations are published in Part B.2.2 of the Community designs Bulletin, while transfers of rights are published in Part B.2.1. Changes in the representatives are published in Part B.9 of the Community designs Bulletin.

11.2.4 Transfers

11.2.4.1 Introduction

A Community design registration may be transferred by the holder, and transfers are recorded upon request in the Register. However, the request for recording a transfer in respect of an international design designating the European Union must be filed with the International Bureau (see Article 16 of the Geneva Act).

The legal provisions contained in the CDR, CDIR and CDFR in respect of transfers correspond to the provisions in the CTMR, CTMIR and CTMFR respectively (see the Guidelines on Community Trade Marks, Part E, Chapter 1, on Transfer).

The legal principles and procedure for the recordal of trade mark transfers apply *mutatis mutandis* to Community designs with the following particularities.

11.2.4.2 Rights of prior use in respect of a registered Community design

The right of prior use in respect of a registered Community design cannot be transferred except, where the third person, who claimed said right before the filing or priority date of the application for a registered Community design, is a business, along with that part of the business in the course of which the act was done or the preparations were made (Article 22(4) CDR).

11.2.4.3 Fees

The fee of EUR 200 for the recordal of a transfer applies per design, with an upper limit of EUR 1 000 if multiple requests are submitted in the same application (points 16 and 17 of the annex to the CDFR).

11.2.5 Licences

11.2.5.1 General principles

Community design registrations may be licensed by the holder and the licences recorded upon request in the Register. The provisions of the CDR and CDIR dealing with Community design licences (Articles 27, 32 and 33, and Article 51(4) CDR; Articles 24 and 25, and Article 27(2) CDIR) are almost identical to those in the CTMR and CTMIR (see the Guidelines on Community Trade Marks, Part E, Chapter 2, on Licences).

The legal principles and procedure for the recordal of licences in respect of Community trade marks apply *mutatis mutandis* to Community designs (Article 24(1) CDIR) with the following particularities.

11.2.5.2 Registered Community designs

There is no use requirement in Community design law. Therefore, the issue of whether use by a licensee is use with the consent of the right holder does not arise.

The CDR and CDIR require an indication of the products in which the design is intended to be incorporated or applied (see paragraph 6.1.4 above.). A partial licence for only some of the products in which the design is intended to be incorporated or applied is not possible.

Any limitations of the scope of the licence will therefore be disregarded by the Office, and the licence will be registered as if there were no such limitations.

11.2.5.3 Multiple applications for registered Community designs

An application for a registered Community design may take the form of a multiple application combining several designs (Article 37 CDR).

Each design contained in a multiple application may be licensed independently of the others (Article 24(1) CDIR).

11.2.5.4 Fees

The fee of EUR 200 for the recordal, transfer or cancellation of a licence applies per design, not per application, with a ceiling of EUR 1 000 if multiple requests are submitted in the same application (points 18 and 19 of the annex to the CDFR).

Example 1: From a multiple application for ten designs, six designs are licensed to the same licensee. The fee for registering the licences is EUR 1 000, provided that

- all six licences are included in a single registration request, or
- all the relevant requests are submitted on the same day.

The request may indicate that, for three of these six designs, the licence is an exclusive one, without this having any impact on the fees to be paid.

Example 2: From a multiple application for ten designs, five designs are licensed to the same licensee. A licence is also granted for another design not contained in that multiple application. The fee is EUR 1 000, provided that:

- all six licences are included in a single registration request, or that all the relevant requests are submitted on the same day, and
- the holder of the Community design and the licensee are the same in all six cases.

12 International Registrations

This part of the Guidelines deals with the particularities of examining international registrations designating the European Union that result from applications filed with the International Bureau of the World Intellectual Property Organisation (hereinafter referred to as 'international registrations' and 'the International Bureau') under the Geneva Act of 02/07/1999 of the Hague Agreement concerning the international registration of industrial designs.

12.1 General overview of the Hague System

12.1.1 The Hague Agreement and the Geneva Act

The Hague Agreement is an international registration system that makes it possible to obtain protection for designs in a number of States and/or intergovernmental organisations, such as the European Union or the African Intellectual Property Organization, by means of a **single** international application filed with the International Bureau. Under the Hague Agreement, a single international application replaces a whole series of applications which, otherwise, would have had to be filed with different national intellectual property offices or intergovernmental organisations.

The Hague Agreement consists of three separate international treaties: the London (1934) Act, the application of which has been frozen since 01/01/2010, the Hague (1960) Act and the Geneva (1999) Act. Each Act has a different set of legal provisions, which are independent of one another.

International registrations designating the European Union are governed by the Geneva Act.

Unlike the Madrid ‘Protocol Relating to the Madrid Agreement Concerning the International Registration of Marks’, neither the Geneva Act nor the CDR provides for procedures for converting or transforming an international registration into Community or national designs or into designations of Member States party to the Hague System, or for replacing Community or national designs by an international registration designating the contracting party in question.

12.1.2 Procedure for filing international applications

12.1.2.1 Particularities

Another difference with the Madrid System is that the Geneva Act does neither allow nor require an international registration to be based on a previously filed Community or national design. OHIM can only be a ‘designated office’, not an ‘office of origin’. International applications must therefore be filed directly with the International Bureau (Article 106b CDR).

The Geneva Act and the Common Regulations under the 1999 Act and the 1960 Act of the Hague Agreement (‘CR’) contain specific rules, which may differ from those applicable to ‘direct filings’ of Community designs, that is, applications filed directly with OHIM or via the central industrial property office of a Member State or, in Benelux countries, the Benelux Office for Intellectual Property (BOIP) (see paragraph 2.2.1 above). These specific rules relate, in particular, to entitlement to file an international application, the contents of an international application, fees, deferment of publication, the number of designs that may be included in a multiple application (up to 100), representation before the International Bureau and the use of languages (an international application must be in English, French, or Spanish).

12.1.2.2 Deferment of publication

An international application may contain a request that publication of the design, or of **all** the designs contained in a multiple application, be deferred. The Geneva Act does

not allow deferment of publication to be requested for only some of the designs contained in a multiple application (Article 11 of the Geneva Act).

The period of deferment of publication for an international application designating the European Union is 30 months from the filing date or, where priority is claimed, the priority date. The application will be published at the end of this 30-month period, unless the holder submits a request for earlier publication to the International Bureau (Article 11 of the Geneva Act).

The procedure described in paragraph 6.2.5 above does **not** apply as the Office is not responsible for publishing international registrations designating the European Union.

12.1.2.3 Fees

Three types of fees⁶ must be paid for an international application designating the European Union, namely:

- a basic fee
- a publication fee
- an individual designation fee, that is, EUR 62 per design, converted into Swiss francs (Article 106c CDR; Article 1a to the Annex of the CDFR; Rule 28 CR).

12.1.3 Examination carried out by the International Bureau

When it receives an international application, the International Bureau checks that it complies with the prescribed **formal** requirements, such as those relating to the quality of the reproductions of the design(s) and the payment of the required fees. The applicant is informed of any deficiency, which must be corrected within the prescribed time limit of three months, failing which the international application is considered to be abandoned.

Where an international application complies with the prescribed formal requirements, the International Bureau records it in the International Register and (unless deferment of publication has been requested) publishes the corresponding registration in the 'International Designs Bulletin'. Publication takes place electronically on the website of the World Intellectual Property Organization ('WIPO') and contains all relevant data concerning the international registration, including a reproduction of the design(s).

The International Bureau notifies the international registration to all designated offices, which then have the option of refusing protection on substantive grounds.

12.2 The role of the Office as designated office

It will be explained below how international registrations are dealt with by the Office from notification by the International Bureau through to the final decision to accept or refuse the designation of the European Union.

The main steps before the Office as designated office are:

⁶ See www.wipo.int/hague/en/fees

- receipt of the international registration designating the European Union;
- examination of the grounds for non-registrability.

12.2.1 Receipt of the international registration designating the European Union

Communications between the Office and the International Bureau are by electronic means (Article 43(3) CDIR).

12.2.2 Grounds for non-registrability

Once the international registration designating the European Union has been notified to the Office by the International Bureau, the rules laid down under Title XIa CDR and Article 11a CDIR (Examination of grounds for refusal) apply (Article 106a(1) CDR).

12.2.2.1 Compliance with the definition of a design, public policy and morality

An international registration may not be refused on the grounds of non-compliance with **formal** requirements, since such requirements are to be considered as already satisfied following examination by the International Bureau.

The Office limits its examination to the two grounds for non-registrability (Article 11a CDIR). An international application will be refused if a design does not correspond to the definition in Article 3(a) CDR or if it is contrary to public policy or accepted principles of morality (Article 9 CDR) (see paragraph 4 above).

The examination of grounds for non-registrability for international registrations will be carried out as if the design(s) had been applied for directly with the Office. The time limits and other general procedural aspects governing said examination are the same as those that apply in the case of design applications filed directly at the Office (see Introduction, paragraph 1.2.3, and paragraph 4.3 above).

12.2.2.2 Time limits

The Office must inform the International Bureau of any refusal of protection within **six months** of publication of the international registration on the WIPO website (Article 11a(1) CDIR).

A preliminary refusal must be reasoned and state the grounds on which refusal is based, and the holder of the international registration must be given an opportunity to be heard (Article 106e(1) and (2) CDR).

Thus, within two months of the date of receipt of the notification of provisional refusal by the international registration holder, the latter will be given the opportunity to renounce the international registration, to limit the international registration to one or some of the designs for the European Union or to submit observations (Article 11a(2) CDIR).

The International Bureau will forward the notification of provisional refusal to the holder (or to its representative before WIPO if applicable). The holder must reply direct to the Office or, if applicable, through his representative (see paragraph 12.2.2.4 below).

For time-limit extensions, see Introduction, paragraph 1.2.3.

12.2.2.3 Languages

An international application must be filed in English, French or Spanish (Rule 6(1) CR). The recording and publication of the international registration will indicate the language in which the international application was received by the International Bureau (Rule 6(2) CR). In practice, this language can be identified from the product indication (INID code 54): the first language used in the product indication is the language in which the international application was received by the International Bureau. The indications given in the other two languages are translations provided by the International Bureau (Rule 6(2) CR).

The language in which the international application was received by the International Bureau will be the first language of the EU designation and will therefore become the language of the examination proceedings (Article 98(1) and (3) CDR).

In all communications with the International Bureau, the Office will therefore use the language in which the international registration was filed.

If the holder wishes to use a different Office language, it must supply a translation into the language in which the international registration was filed, within one month of the date of submission of the original document (Article 98(3) CDR; Article 81(1) CDIR). If no translation is received within this time limit, the original document is deemed not to have been received by the Office.

12.2.2.4 Professional representation

The holder may, if representation is mandatory under Article 77(2) CDR (see paragraph 2.5 above), be requested to appoint, within two months, a professional representative before the Office in accordance with Article 78(1) CDR (Article 11a(3) CDIR).

If the holder fails to appoint a representative within the specified time limit, the Office will refuse protection of the international registration (Article 11a(4) CDIR).

12.2.2.5 Renunciation and limitation

Where the holder renounces the international registration or limits it to one or some of the designs for the European Union, it must inform the International Bureau by way of recording procedure in accordance with Article 16(1)(iv) and (v) of the Geneva Act. The holder can inform the Office by submitting a corresponding statement (Article 11a(6) CDIR).

12.2.2.6 Grant of protection

Where the Office finds no grounds for refusing protection or where a preliminary refusal is withdrawn, the Office must inform the International Bureau accordingly without delay.

12.2.2.7 Refusal

Where the holder does not submit observations that satisfy the Office within the specified time limit or does not withdraw the application, the Office will confirm its decision refusing protection for the international registration. If the refusal concerns only some of the designs contained in a multiple international registration, the Office will refuse the latter only insofar as those designs are concerned (Article 11(3) CDIR).

There is no legal provision in the CDR or CDIR allowing an applicant to request an amendment of the design in order to overcome an objection concerning an international registration. On the other hand, an applicant may renounce the designation of the European Union by addressing WIPO directly, who will then notify the Office.

The holder of the international registration has the same remedies available to it as it would have had if it had filed the design(s) in question directly with the Office. The ensuing procedure takes place solely at Office level. An appeal against a decision to refuse protection must be submitted by the holder to the Boards of Appeal, within the time limit and in accordance with the conditions set out in Articles 55 to 60 CDR and Articles 34 to 37 CDIR (Article 11a(5) CDIR). The International Bureau is not involved in this procedure at all.

Once the decision to refuse or accept the international registration is final, a final notification will be sent to the International Bureau, indicating whether the design(s) has / have been finally refused or accepted.

Where the final refusal relates to only some of the designs contained in a multiple application, the notification to the International Bureau will indicate which designs have been refused and which accepted.

12.3 Effects of International registrations

If no refusal is notified by the Office within six months of the publication of the international registration on the WIPO website, or if a notice of preliminary refusal is withdrawn, the international registration will, from the date of registration granted by the International Bureau, as referred to in Article 10(2) of the Geneva Act (Article 106a(2) CDR), have the same effect as if it had been applied for with, and registered by, the Office.

International registrations can be subject to invalidity proceedings under the same conditions and procedural rules as 'direct filings' (Article 106f CDR; see the Guidelines on the Examination of Design Invalidation Applications). Since the language of filing of an international registration designating the European Union is necessarily an Office language, an application for a declaration of invalidity against such an international registration must be filed in this language.

The Office will notify the holder or their representative direct of any request for a declaration of invalidity. The holder must reply direct to the Office or, if applicable, through a representative who is on the Office's list in accordance with Article 78 CDR (see paragraph 2.5 above).

Where the Office declares the effects of an international registration invalid in the territory of the European Union, it must inform the International Bureau of its decision as soon as the latter becomes final (Article 106f(2) CDR; Article 71(3) CDIR).

The particularities of the procedures governing the renewal of international registrations and records of changes of name, transfers, renunciation or limitation of certain designs, for any or all of the designated contracting parties, are dealt with in the Guidelines Concerning Proceedings before the Office on Renewal of Registered Community Designs and at paragraphs 11.2.2 to 11.2.4 (Articles 16 and 17 of the Geneva Act; Article 22a CDIR).

13 Enlargement and the Registered Community Design

This section discusses the rules relating to the accession of new Member States to the European Union and the consequences thereof for applicants for, and holders of, registered Community designs.

Ten new Member States joined the European Union on 01/05/2004 (Czech Republic, Estonia, Cyprus, Latvia, Lithuania, Hungary, Malta, Poland, Slovenia and Slovakia), two on 01/01/2007 (Bulgaria and Romania) and one on 01/07/2013 (Croatia), bringing the number of Member States up to 28.

Article 110a CDR contains provisions relating to enlargement as regards registered Community designs. These provisions were inserted in the CDR when the EU was enlarged in 2004 and remain applicable for successive enlargements. The only modification to the text of the CDR is the addition of the names of the new Member States.

As far as registrability and validity of Community designs are concerned, the effects of the enlargement of the European Union on registered Community design rights are the following.

13.1 The automatic extension of the Community design to the territories of the new Member States

Pursuant to Article 110a(1) CDR, the effects of all Community design rights filed before 01/05/2004, 01/01/2007 or 01/07/2013 extend automatically to the territories of the Member States that acceded on those dates (Article 110a(1) CDR).

Extension is automatic in the sense that it does not have to undergo any administrative formality and does not give rise to any extra fees. Moreover, it cannot be opposed by the Community design holder or any third party.

13.2 Other practical consequences

13.2.1 Filing with national offices

As from the enlargement date, a Community design application may also be filed through the industrial property office of a new Member State.

13.2.2 Professional representation

As from the accession date, applicants (as well as other parties to proceedings before the Office) who have their seat or domicile in a new Member State no longer need to be represented by a professional representative. As from the accession date, professional representatives from a new Member State may be entered on the list of professional representatives maintained by the Office pursuant to Article 78 CDR and may then represent third parties before the Office.

13.2.3 First and second language

Since 01/01/2004 there have been nine new official EU languages, namely Czech, Estonian, Latvian, Lithuanian, Hungarian, Maltese, Polish, Slovak and Slovenian. A further two languages (Bulgarian and Romanian) were added on 01/01/2007⁷ and a further one (Croatian) on 01/07/2013.

These languages may be used as the first language only for Community design applications filed on or after the accession date concerned.

13.2.4 Translation

Community design applications with a filing date prior to the accession date, or existing Community design registrations, will neither be translated into, nor republished in the language of the new Member State(s). Community design applications filed after the accession date will be translated and published in all official EU languages.

13.3 Examination of grounds for non-registrability

The Office limits its examination of the substantive protection requirements to only two grounds for non-registrability (Article 47(1) CDR). An application will be refused if the design does not correspond to the definition provided for at Article 3(a) CDR or if it is contrary to public policy or to accepted principles of morality (Article 9 CDR) (see paragraph 4 above).

An application for a registered Community design cannot be refused on the basis of any of the grounds for non-registrability listed in Article 47(1) CDR if these grounds become applicable merely because of the accession of a new Member State (Article 110a(2) CDR).

⁷ For Irish, see paragraph 2.4

Whether a Community design is in conformity with Article 3 CDR or complies with public order and accepted principles of morality is normally assessed without reference to any particular national or linguistic context.

However, where a Community design contains an offensive word element in a language which, as a result of the accession of a new Member State, becomes an official language of the European Union after the date of filing, the absolute ground of refusal provided for under Article 9 CDR does not apply.

13.4 Immunity against cancellation actions based on grounds of invalidity which become applicable merely because of the accession of a new Member State

13.4.1 General principle

Community designs filed or registered before 01/05/2004, 01/01/2007 or 01/07/2013 will not be cancelled on the basis of grounds for invalidity that exist in one of the Member States acceding to the European Union on those dates if the ground for invalidity only became opposable as from the accession date in question (Article 110a(3) CDR). This is an expression of the need to respect acquired rights.

Not all grounds of invalidity set out in Article 25(1) CDR may become 'applicable merely because of the accession of a new Member State'.

13.4.1.1 Grounds of invalidity that are applicable independently of the enlargement of the EU

The accession of a new Member State has no effect on the applicability of the following four grounds for invalidity. Article 110a(3) CDR therefore does not offer any protection against their application to Community designs filed before 01/05/2004, 01/01/2007 or 01/07/2013 respectively.

Non-visibility and functionality

The non-visibility of a Community design applied to a part of a complex product and the restrictions applying to features of a design that are solely dictated by technical function or the requirements of interconnection, are grounds of invalidity that must be evaluated on the basis of the design itself and not of a factual situation that exists in any given Member State (Article 25(1)(b) CDR read in combination with Article 4 and 8 CDR).

Novelty and individual character

Under normal circumstances, lack of novelty or individual character of a Community design will not be affected by enlargement of the EU (Article 25(1)(b) CDR read in combination with Article 5 and 6 CDR).

The disclosure of a design prior to the filing or priority date of a Community design can destroy the latter's novelty or individual character, even if such disclosure took place in a country before the date of its accession to the EU. The sole requirement is that such disclosure could 'reasonably have become known in the normal course of business in

the circles specialised in the sector concerned operating in the Community' (Article 7(1) CDR).

Entitlement to the Community design

The fact that the holder is not entitled to the Community design as a result of a court decision is another ground for invalidity that is not affected by enlargement (Article 25(1)(c) CDR). Article 14 CDR does not impose any nationality requirement for the person claiming to be entitled to the Community design, nor does it require that the court decision originates from a court located in a Member State.

Improper use of one or more of the elements listed in Article 6ter of the Paris Convention

The invalidity ground of improper use of one or more of the elements listed in Article 6ter of the Paris Convention is not affected by enlargement of the EU either. There is no requirement for the sign of which use is prohibited to come from a Member State (Article 25(1)(g) CDR).

13.4.1.2 Grounds of invalidity resulting from enlargement of the EU

A Community design filed on or before 30/04/2004, 31/12/2006 or 30/06/2013 respectively cannot be invalidated on the basis of the four grounds of invalidity referred to below where any of these grounds becomes opposable as a result of the accession of a new Member State on those dates (Article 110a(3) CDR).

Conflict with a prior design right protected in a new Member State (Article 25(1)(d) CDR)

A Community design filed before the date of accession of a Member State cannot be invalidated on the basis of a conflict with an earlier design that has enjoyed protection in the new Member State since a date prior to the filing or priority date of the Community design but that was disclosed to the public at a later date.

Use of an earlier distinctive sign (Article 25(1)(e) CDR)

A Community design filed before the date of accession of a Member State cannot be invalidated on account of the use of a distinctive sign that has enjoyed protection in the new Member State since a date prior to the filing or priority date of the Community design.

Unauthorised use of a work protected under the copyright law of a Member State (Article 25(1)(f) CDR)

A Community design filed before the date of accession of a Member State cannot be invalidated on account of the non-authorised use of a work that has been protected by the copyright law of the new Member State since a date prior to the filing or priority date of the Community design.

Improper use of signs, emblems, coats of arms, other than those covered by Article 6ter of the Paris Convention (Article 25(1)(g) CDR)

A Community design filed before the date of accession of a Member State cannot be invalidated on account of the improper use of signs, emblems or coats of arms, other than those covered by Article 6ter of the Paris Convention, that are of particular public interest for the new Member State.

Public policy and morality

A Community design filed before the date of accession of a new Member State cannot be invalidated on account that it is contrary to public policy or morality in the territory of that new Member State.

13.4.2 Effects of a priority claim

Community designs with a filing date on or after 01/05/2004, 01/01/2007 or 01/07/2013 respectively may be invalidated on the basis of the four grounds mentioned above.

This applies even if the priority date of the Community design in question precedes the relevant accession date. The priority right does not protect the Community design holder against any change in the law that is applicable to the validity of its design.

***GUIDELINES FOR EXAMINATION IN THE
OFFICE FOR HARMONIZATION IN THE
INTERNAL MARKET (TRADE MARKS AND
DESIGNS) ON REGISTERED COMMUNITY
DESIGNS***

***RENEWAL OF REGISTERED COMMUNITY
DESIGNS***

Table of Contents

1. Introduction.....	3
2. FRAUD WARNING	3
2.1. Private companies sending misleading invoices.....	3
2.2. Renewal by unauthorised third persons.....	4
2.3. Contact.....	4
3. Term of Protection.....	4
4. Notification of Expiry of Registration	4
5. Fees and Other Formal Requirements for the Request for Renewal	5
5.1 Persons who may submit a request for renewal	5
5.2 Content of the request for renewal.....	6
5.3 Languages	6
5.4 Fees	7
5.5 Time limits	7
5.5.1. Six months period for renewal before expiry (basic period)	7
5.5.2 Six months grace period following expiry (grace period)	8
5.6 Means of payment	8
6 Procedure before the Office	9
6.1 Competence.....	9
6.2 Examination of formal requirements.....	9
6.2.1 Observance of time limits	9
6.2.2 Compliance with formal requirements	11
6.3 Items not to be examined.....	11
6.4 Alteration	12
6.5 Restitutio in integrum	12
7 Entries in the Register.....	12
8 Date of Effect of Renewal or Expiry	13
9 Renewal of International Design Registrations Designating the European Union.....	13

1. Introduction

There are two ways of applying for a registered Community design: either (i) via a 'direct filing' at the Office or a national Office (Article 35 et seq. CDR) or (ii) via an international registration filed with the International Bureau of the World Intellectual Property Organisation and designating the European Union (Article 106a et seq. CDR).

The purpose of the Guidelines is to explain how, in practice, the requirements of the Community Design Regulation¹ (CDR), the Community Design Implementing Regulation² (CDIR) and the Fees Regulation³ (CDFR) are applied by the Office in respect of renewal procedures relating to 'direct filings' of Community designs (see paragraphs 3 to 8 below). The Guidelines are not intended to, and cannot, add to or subtract from the legal contents of the Regulations.

Paragraph 9 below makes reference to the relevant instruments applicable to the renewal of international registrations designating the European Union.

2. FRAUD WARNING

2.1. Private companies sending misleading invoices

The Office is aware that users in Europe are receiving an increasing amount of unsolicited mail from companies requesting payment for trade mark and design services such as renewal.

A list of letters from firms or registers, which users have complained are misleading, is published on the Office website. Please note that these services are not connected with any official trade mark or design registration services provided by IP Offices or other public bodies within the European Union such as OHIM.

If you receive a letter or invoice please check carefully what is being offered to you, and its source. Please note that the **OHIM never sends invoices to users or letters requesting direct payment for services** (see the Guidelines, Part A, General Rules, Section 3, Payment of fees, cost and charges).

¹ [Council Regulation \(EC\) No 6/2002 of 12 December 2001 on Community Designs](#), as amended by Council Regulation No 1891/2006 of 18 December 2006 amending Regulations (EC) No 6/2002 and (EC) No 40/94 to give effect to the accession of the European Community to the Geneva Act of the Hague Agreement concerning the international registration of industrial designs

² [Commission Regulation \(EC\) No 2245/2002 of 21 October 2002 implementing Council Regulation \(EC\) No 6/2001 on Community designs](#), as amended by Commission Regulation (EC) No 876/2007 of 24 July 2007 amending Regulation (EC) No 2245/2002 implementing Council Regulation (EC) No 6/2002 on Community designs following the accession of the European Community to the Geneva Act of the Hague Agreement concerning the international registration of industrial designs

³ [Commission Regulation \(EC\) No 2246/2002 of 16 December 2002 on the fees](#), as amended by Commission Regulation (EC) No 877/2007 of 24 July 2007 amending Regulation (EC) No 2246/2002 concerning the fees payable to the Office for Harmonization in the Internal Market (Trade Marks and Designs) following the accession of the European Community to the Geneva Act of the Hague Agreement concerning the international registration of industrial designs

2.2. Renewal by unauthorised third persons

The Office is also aware that fraudsters have targeted the e-renewal module, applying for renewal without proprietors' consent and thus blocking renewal via the module for persons legitimately authorised to renew in this way. The technical block is designed to prevent a renewal being paid for twice. If, when you file a request for e-renewal, you discover that the mark is 'blocked' because renewal has already been requested, please contact the Office.

2.3. Contact

If you have any doubts or detect any new cases, please check with your legal advisers or contact us by telephone on +34 965 139 100 or by e-mail at information@oami.europa.eu

3. Term of Protection

Articles 12, 38 CDR Article 10 CDIR
--

The term of protection of a registered Community design (RCD) is five years from the **date of filing** of the application (Article 12 CDR).

The date of filing of the application is determined according to Article 38 CDR and Article 10 CDIR (see the Guidelines concerning Applications for Registered Community Designs, Section 2, 'Allocation of a filing date').

Registration may be renewed for one or more periods of 5 years each, up to a total of 25 years from the date of filing.

4. Notification of Expiry of Registration

Article 13(2) CDR Article 21 CDIR

At least six months before the expiry of the registration, the Office will inform:

- the holder of the Community design and
- any person having a registered right in respect of the Community design

that the registration is approaching expiry. Persons having a registered right include the holders of a registered licence, the proprietors of a registered right *in rem*, the creditors of a registered levy of execution or the authority competent to act on behalf of the proprietor in insolvency procedures.

Failure to give such information does not affect the expiry of the registration and does not involve the responsibility of the Office.

5. Fees and Other Formal Requirements for the Request for Renewal

Article 22(8), Articles 65, 66, 67, Article 68(1) (e) CDIR

The general rules concerning communications to the Office apply, which means that the request for renewal may be submitted as follows:

- by electronic means available on the OHIM Website (e-renewal). Entering the name and surname in the appropriate place on the electronic form is deemed to be a signature. Using e-renewal offers advantages such as the receipt of immediate electronic confirmation of the renewal request automatically or the use of the renewal manager feature to complete the form quickly for as many registered Community designs as needed.
- by transmitting a signed original form by fax, mail, or by any other means. A standard form is available on the OHIM website. Forms have to be signed but annexes need not be.

It is strongly recommended to renew Community design registrations by electronic means ('e-renewal'). The process of electronic renewal automatically checks and validates the requirements laid down in the CDIR.

A single application for renewal may be submitted for two or more designs, whether or not part of the same multiple registration, upon payment of the required fees for each of the designs, provided that the Community design holders or the representatives are the same in each case.

For Fees see paragraph 5.4, for Compliance with formal requirements see paragraph 6.2.2.

5.1 Persons who may submit a request for renewal

Article 13(1) CDR

Requests for renewal may be submitted by:

- the registered proprietor of a Community design;
- the successor in title where a Community design has been transferred, with effect from when the request for registration of the transfer was received by the Office;
- a person authorised by the proprietor of a Community design to do so. Such a person may, for instance, be a registered licensee, a non-registered licensee or any other person who has obtained the proprietor's authorisation to renew the Community design;
- a representative acting on behalf of any of the above persons.

Persons obliged to be represented before the Office pursuant to Article 77(2) CDR can submit a request for renewal directly.

When the renewal request is submitted by a person other than the registered proprietor, an authorisation will have to exist in its favour; however, it does not need to be filed with the Office unless the Office requests it. For example, if the Office receives

fees from two different sources, the owner will be contacted in order to know which person is authorised to file the renewal request. Where no reply is received from the owner, the Office will validate the payment that reached the Office first (see, by analogy, judgment of 12/05/2009, T-410/07, 'Jurado', paras 16-24).

5.2 Content of the request for renewal

Article 22(1) CDIR

A request for renewal of registration must contain the following:

- The name of the person requesting renewal (that is, the Community design proprietor or an authorised person or representative; see paragraph 5.1). If the Office has allocated an ID number to the applicant for renewal, it is sufficient to indicate this number.
- The registration number of the registered Community design. This number is always composed of a nine-digit root, followed by a four-digit ending (e.g. XXXXXXXXX-YYYY).
- In the case of a multiple registration, an indication that renewal is requested for all the designs covered by the multiple registration or, if the renewal is not requested for all the designs, an indication of those for which it is requested.

Where the Community design holder has appointed a representative, the name of the representative should be mentioned. If the representative is already on record, the indication of their ID number is sufficient. If a new representative is appointed in the request for renewal, their name and address must be given in accordance with Article 1(1)(e) CDIR

Payment alone can constitute a valid request for renewal providing such payment timely reaches the Office and contains the name of the payer, the registration number of the Community design and the indication 'renew'. In such circumstances no further formalities need be complied with (see *The Guidelines Concerning Proceedings Before The Office for Harmonization In The Internal Market (Trade Marks And Designs) Part A, General Rules, Section 3, Payment of Fees, Costs and Charges*).

5.3 Languages

Article 80(b) CDIR

The request for renewal may be filed in any of the five languages of the Office. This language becomes the language of the renewal proceedings. However, when the request for renewal is filed by using the form provided by the Office pursuant to Article 68 CDIR, such a form may be used in any of the official languages of the Community, provided that the form is completed in one of the languages of the Office, as far as textual elements are concerned.

5.4 Fees

Article 13(3) CDR Article 22(2) (a), (b) CDIR Article 7(1) CDFR Annex to the CDFR, points 11 and 12
--

The fees payable for the renewal of a Community design consist of:

- a renewal fee, which, where several designs are covered by a multiple registration, is proportionate to the number of designs covered by the renewal;
- any additional fee applicable for late payment of the renewal fee or late submission of the request for renewal.

The amount of the renewal fee, per design, whether or not included in a multiple registration, is as follows:

- for the first period of renewal: EUR 90
- for the second period of renewal: EUR 120
- for the third period of renewal: EUR 150
- for the fourth period of renewal: EUR 180.

The fee must be paid within a period of six months ending on the last day of the month in which protection ends (see paragraph 5.5 below).

The fee may be paid within a further period of six months following the last day of the month in which protection ends, provided that an additional fee of 25% of the total renewal fee is paid (see paragraph 5.5.2 below).

When the payment is made by transfer or payment to an Office bank account, the date on which payment is deemed to have been made is the date on which the amount is credited to the Office's bank account.

5.5 Time limits

Article 13 CDR Articles 22(2), 58(1) CDIR
--

5.5.1. Six months period for renewal before expiry (basic period)

The request for renewal and the renewal fee must be submitted within a period of six months ending on the last day of the month in which protection ends (hereinafter referred to as 'the basic period').

If this time limit expires on a day on which the Office is not open for receipt of documents or on which ordinary mail is not delivered in Alicante, it will extend until the first day thereafter on which the Office is open for receipt of documents and on which ordinary mail is delivered. Other exceptions are provided for at Article 58(2) and (4) CDIR.

For example, where the Community design has a filing date of 01/04/2013, the last day of the month in which protection ends will be 30/04/2018. Therefore, a request for

renewal must be introduced and the renewal fee paid between 01/11/2017 and 30/04/2018 or, where this is a Saturday, Sunday or other day on which the Office is closed or does not receive ordinary mail, the first following working day on which the Office is open to the public and does receive ordinary mail.

5.5.2 Six months grace period following expiry (grace period)

Where the relevant time limit is not met, the request for renewal may still be submitted and the renewal fee may still be paid within a further period (hereinafter the 'grace period') of six months following the last day of the month in which the basic period ends, provided that an additional fee of 25% of the total renewal fee is paid within the grace period (see Article 13.3 CDR). Thus, renewal will only be successfully effected if payment of all fees (renewal fees and additional fees for late payment, where applicable) reaches the Office within the grace period.

In the above example, the grace period during which a request for renewal may still be introduced upon payment of the renewal fee plus the additional fee is counted from the day after 30/04/2018, namely from 01/05/2018, and ends on 31/10/2018 or, if 31/10/2018 is a Saturday, Sunday or other day on which the Office is closed or does not receive ordinary mail, the first following working day on which the Office is open to the public and does receive ordinary mail. This applies even if, in the above example, 30/04/2018 was a Saturday or Sunday; the rule that a time limit to be observed vis-à-vis the Office is extended until the next working day applies only once and to the end of the first period, not to the starting date of the grace period.

Fees which are paid before the start of the first six-month period will not, in principle, be taken into consideration and will be refunded.

5.6 Means of payment

Article 5 CDFR

The admissible means of payment are bank transfers, credit cards (only if renewal is applied for electronically via the e-renewal module) and deposits in current accounts held with the Office. Payment cannot be made by cheque. Fees and charges must be paid in euros.

Where the Community design proprietor has a current account at the Office, the fee will be debited automatically from the account once a request for renewal is filed. Unless different instructions are given, the renewal fee will be debited on the last day of the six-month time limit provided for in Article 13(3) CDR, i.e. on the last day of the month in which protection ends.

If a request for renewal is filed late (see paragraph 5.5.2 above), the debit will take place, unless different instructions are given, with effect from the day on which the belated request was filed, and will be subject to a surcharge.

Where the request is submitted by a professional representative within the meaning of Article 78 CDR, who represents the Community design proprietor, and the

representative has a current account before the Office, the renewal fee will be debited from the representative's current account.

Payment may also be made by the other persons identified in paragraph 5.1 above.

Payment by debiting a current account held by a third party requires explicit authorisation from the holder of the current account that the account can be debited for the fee in question. In such cases, the Office will check if authorisation has been given. If none has been given, a letter will be sent to the renewal applicant asking them to submit the authorisation to debit the third party account. In such cases, payment is considered to be made on the date the Office receives the authorisation.

Where the fees (renewal fees and, where applicable, additional fee for late payment) have been paid, but the registered Community design is not renewed (i.e. where the fee has been paid only after expiry of the grace period, or where the fee paid amounts to less than the basic fee plus the fee for late payment/late submission of the request for renewal, or where certain other deficiencies have not been remedied; see paragraph 6.2.2 below), the fees in question will be refunded.

6 Procedure before the Office

6.1 Competence

Article 104 CDR

The Operations Support Department is responsible for treating renewal requests and entering them in the Register.

6.2 Examination of formal requirements

Examination of a request for renewal is limited to formalities as follows.

6.2.1 Observance of time limits

- (a) Before expiry of the basic period

Article 13 CDR Article 22(3) CDIR Article 5, Article 6(1) CDFR
--

Where the request for renewal is filed and the renewal fee paid within the basic period, the Office will record the renewal, provided the other conditions laid down in the CDR and CDIR are fulfilled.

Where no request has been filed before the basic period expires, but the Office receives a payment of the renewal fee that contains the minimum indications (name of the person requesting the renewal and the registration number of the renewed

Community design(s)), this will constitute a valid request and no further formalities will need to be complied with.

However, where no request for renewal has been filed but a renewal fee has been paid that does not contain the minimum indications (name of the person requesting the renewal and the registration number of the renewed Community design(s)), the Office will invite the Community design proprietor to submit a request for renewal and pay, where applicable, the additional fee for late submission of the request for renewal. A letter will be sent out as early as possible after receipt of the fee, so as to enable the request to be filed before the additional fee becomes due.

Where a request has been submitted within the basic period, but the renewal fee has not been paid or has not been paid in full, the Office will invite the person requesting renewal to pay the renewal fee or the remaining part thereof along with the additional fee for late payment.

If the request for renewal is filed by a person authorised by the proprietor of the Community design, the proprietor of the Community design will receive a copy of the notification.

(b) Before expiry of the grace period

Article 13(3) CDR Article 22(4) CDIR

Where a request has been submitted within the additional grace period, but the renewal fee has not been paid or has not been paid in full, the Office will invite the person requesting renewal to pay the renewal fee or the remaining part thereof along with the additional fee for late payment.

Renewal will be effected only if payment of all fees (renewal fees and additional fee for late payment) is made or considered to be made before expiry of the grace period (see paragraphs 5.5 and 5.6 above).

(c) Situation where the proprietor or representative holds a current account

The Office will not debit a current account unless there is an express request for renewal. It will debit the account of the person performing the action (the Community design proprietor, the representative thereof or a third person).

Where the request is filed within the basic period, the Office will debit the renewal fees without any surcharge.

Where the request is filed within the additional period, the Office will debit the renewal fee along with a 25% surcharge (see paragraph 5.4).

6.2.2 Compliance with formal requirements

Article 22, and Article 40 CDIR

Where a request for renewal does not comply with formal requirements (see paragraph 5 Fees and Other Formal Requirements for the Request for Renewal) but such deficiencies can be remedied, the Office will invite the renewal applicant to remedy the deficiencies within a time limit of two months. This time limit applies even if the additional period has already expired.

If the request for renewal is filed by a person authorised by the proprietor of the Community design, the proprietor of the Community design will receive a copy of the notification.

Where a request for renewal has been submitted by two different persons claiming to be authorised by the proprietor of the Community design, the Office will seek clarification on who is the authorised person by contacting the proprietor directly.

Where the deficiencies are not remedied before the relevant time limit expires, the Office will proceed as follows:

- If the deficiency lies in the fact that there is no indication of the designs of a multiple registration to be renewed, and the fees paid are insufficient to cover all the designs for which renewal is requested, the Office will establish which designs the amount paid is intended to cover. In the absence of any other criteria for determining which designs are intended to be covered, the Office will take the designs in the numerical order in which they are represented. The Office will check that the registration has expired for all designs for which the renewal fees have not been paid in part or in full.
- In the case of other deficiencies, the Office will check that the registration has expired and issue a notification of loss of rights to the proprietor or their representative or, where applicable, to the person requesting renewal and any person recorded in the Register as having rights in the Community design(s).

The proprietor may apply for a decision on the matter under Article 40(2) CDIR within two months.

Where the renewal fees have been paid but the registration is not renewed, those fees will be refunded.

6.3 Items not to be examined

No examination will be carried out on renewal in respect of the registrability of the design or correct classification of the design's products. Nor will a registration be reclassified that was registered in accordance with an edition of the Locarno Classification no longer in force at the time of renewal. Such reclassification will not even be available at the proprietor's request.

6.4 Alteration

Article 12(2) CDIR

As a matter of principle, since the representation of a Community design may not be altered after the filing of the application, the submission of additional views or withdrawal of some views at the time of renewal is not accepted.

Other changes that do not alter the representation of the Community design itself (changes of name, address, etc.), and which the owner wishes to have recorded in the Register when the registration is renewed, must be communicated separately to the Office according to the applicable procedures (see the Guidelines concerning Applications for Registered Community Designs, Section 10). They will be included in the data recorded at renewal only if they are recorded in the Register no later than the date of expiry of the Community design registration.

6.5 Restitutio in integrum

Article 67 CDR Article 15 of the Annex to the CDFR

A party to proceedings before the Office may be reinstated in their rights (restitutio in integrum) if they were unable to observe a time limit vis-à-vis the Office in spite of all due care having been taken as required by the circumstances, provided that the failure to observe the time limit had the direct consequence, by virtue of the provisions of the Regulations, of causing the loss of a right or means of redress.

Restitutio in integrum is only available upon application to the Office and is subject to a fee (EUR 200).

The application must be made within two months from removal of the cause of non-compliance but in any event not later than one year after expiry of the unobserved time limit. The act omitted must be completed within the same period.

In the case of failure to submit a request for renewal or to pay the renewal fee, the time limit of one year starts on the day on which the protection ends (basic period), not on the date of expiry of the further period of six months (additional period).

7 Entries in the Register

Article 13(4) CDR Article 40, Article 22(6), Article 69(3)(m), Article 69(5), Article 71 CDIR

Where the request for renewal complies with all the requirements, the renewal will be entered in the Register.

The Office will notify the Community design proprietor or their representative of the renewal of the design, its entry in the Register and the date from which renewal takes effect.

The Office, where it has determined that the registration has expired, will inform the Community design proprietor or their representative and any person recorded in the Register as having rights in the Community design of the expiry of the registration and its cancellation from the Register.

The proprietor may apply for a decision on the matter under Article 40(2) CDIR within two months.

8 Date of Effect of Renewal or Expiry

Article 13(4) CDR Article 22(6), Article 56 CDIR

Renewal will take effect from the day following that on which the existing registration expires.

Where the Community design has expired and is cancelled from the Register, the cancellation will take effect from the day following that on which the existing registration expired.

9 Renewal of International Design Registrations Designating the European Union

Article 17 of the Geneva Act of the Hague Agreement Concerning the International Registration of Industrial Designs (the 'Geneva Act') Article 12 CDR
--

International registrations designating the European Union are protected for an initial term of 5 years from the date of the international registration, and may be renewed for additional terms of 5 years, up to a total term of 25 years from the date of registration.

Pursuant to Article 11a of the Annex to the CDFR, the individual renewal fees for an international registration designating the European Union, per design, are as follows:

- for the first period of renewal: EUR 31
- for the second period of renewal: EUR 31
- for the third period of renewal: EUR 31
- for the fourth period of renewal: EUR 31.

International registrations must be renewed directly at the International Bureau of WIPO in compliance with Article 17 of the Geneva Act (Article 22a CDIR). The Office will not deal with renewal requests or payments of renewal fees in respect of international registrations.

The procedure for the renewal of international marks is managed entirely by the International Bureau, which sends out the notice for renewal, receives the renewal fees and records the renewal in the International Register. When international registrations designating the EU are renewed, the International Bureau also notifies the Office.